

**The**

**BIG**

**Antenna**

**Book**



**By**

**James R. Cunningham**

FM and AM ALLOCATIONS  
CORRECT "PROCEDURE"

STEP NUMBER ONE:

In Countries where the standard of living is higher, the normal Procedure is as follows:

(A) A Lawyer or Business Man of respectful reputation should enter the Office Of Communications, (there are various names for this Agency) and explain what you wish to accomplish. It will be helpful to have Coverage Maps, Engineering Studies, and an Engineer available who can explain the technical aspect of your proposed "Station" to the Government.

(B) Request a Construction Permit - If there is a frequency available, they will supply you with the needed information.

(C) Fill out the Government Forms and pay the required Fees.

(D) Meet all other Requirements of the Government in charge - Regional and Local.

PROCEDURES  
for  
LESS DEVELOPED NATIONS

1. Do an "ENGINEERING STUDY" and locate a frequency for AM or FM as desired. An Engineer charges for this work.

2. Take your proposal before the Office of Telecommunications or other Office that may be involved.

3. Present to them the following:

(A) Your Frequency (B) Power (C) Location of Antenna or Tower (D) Type of Equipment to be used (if applicable). Many Nations do not require "TYPE APPROVAL" of Radio Equipment.

IN EITHER CASE:

It is advisable to allow only a LAWYER or LOCAL BUSINESS PERSON to deal with the Government while requesting a Frequency or Construction Permit. PASTORS, EVANGELISTS AND FOREIGNERS MUST BE AWARE OF THE FACT THAT THEY MAY NOT BE "TRUSTED" IN MATTERS OF POLITICS AND DEALING WITH THE GOVERNMENT. Use Wisdom and move directly ahead, using "Locals" in every case possible.

PROGRAM MATERIAL

It is usually necessary to show the Government what "FORMAT" you will be using. Use Wisdom and try to show that the Station will help everybody, building up the entire Community. NEWS, WEATHER and INFORMATION can benefit everyone. SATELLITE FEED and AUTOMATION Services may be available, but do not rely on them entirely. Show National, Regional and Local involvement from the start.

FCC REGULATIONS FOR SHORT TOWERS  
WITH 120 GROUND RADIALS

RADIATION AT 1 KW - 150 MVM DISTANCE: 1 mile

500 WATTS - 112.5 MVM

250 WATTS - 75 MVM

125 WATTS - 56.25 MVM

62.5 WATTS - 37.5 MVM

31.25 WATTS - 28.125 MVM

15.625 WATTS - 18.75 MVM

3.9 WATTS - 9.375 MVM

.975 WATTS - 4.68 MVM

.24375 WATTS - 2.34 MVM

100 MW (.1 W.) - 1.17 MVM

FCC EXPECTED FIELD STRENGTHS FOR  
NORMAL 1/4 WAVE LENGTH TOWERS

RADIATION AT 1 KW - 196 MVM at 1 Mile

500 WATTS - 147 MVM

250 WATTS - 98 MVM

125 WATTS - 73.5 MVM

62.5 WATTS - 49 MVM

31.25 WATTS - 36.75 MVM

15.625 WATTS - 24.5 MVM

3.9 WATTS - 12.25 MVM

.975 WATTS - 6.125 MVM

.24375 WATTS - 3.06 MVM

100 MW (.1 WATT) - 2.121 MVM

Calculations are valid for Towers/Antennas  
having 120 Quarter Wave Length Ground  
Radials as per FCC Regulations.

Courtesy of  
James R. Cunningham  
1997

COMPARISONS OF SUBSTANDARD ANTENNAS  
WITH A STANDARD QUARTER WAVELENGTH  
VERTICAL WITH 120 GROUND RADIALS

1. QUARTER WAVELENGTH VERTICAL WITH 120 RADIALS OF ONE QUARTER WAVELENGTH, MINIMUM. EXPECTED RADIATION IS 196 MVM at 1 mile.

SUBSTANDARD ANTENNAS

A. Quarter wavelength wire, end fed, 20 feet above marsh land, with one 1/4 wavelength radial beneath antenna wire: RADIATION, 1 KW: 35.3 MVM or 18 percent efficiency.

B. 15 to 20 foot vertical mast, series fed, with one 1/4 wavelength ground radial over marshy land: 10.182 MVM with 1KW transmitter power, or 5.2 percent efficiency.

C. 15 to 20 foot mast antenna, series fed, with 20 X 20 foot ground plane beneath, but no earth ground (ground screen is elevated and insulated from earth) Radiation is: 1.414 MVM with 1 KW Transmitter power, or .72 percent efficiency.

D. Same vertical mast antenna as above, but with a single .1 wavelength counterpoise wire radial, isolated from earth ground: 7.07 MVM with 1 KW. or 3.6 percent efficiency as compared to the FCC Standard.

E. 15 to 20 foot vertical mast as above, series fed, with a return wire from top to bottom which is grounded to a quarter wavelength earth grounded radial by way of a series tuning capacitor: .07 MVM at 1 mile with 1KW Transmitter.

F. Same as above, but tuned to resonance with a series coil and capacitor combination: .7 - 1 MVM at 1 mile with 1KW Transmitter power. .36 percent efficiency.

G. One quarter wavelength wire in a square or circle using 4 to 10 poles, at 20 feet above earth, with a single earth ground: 21 to 28 MVM at 1 mile & 1KW. This gives appx. 14 percent efficiency.

SUB STANDARD  
AM ANTENNA RADIATION TESTS  
"conducted over marshy land"

ALL TESTS PERFORMED AT 20 WATTS TRANSMITTER OUTPUT POWER TO ANTENNA

1. 1/4 wavelength wire antenna 20 feet above marshy land with one 1/4 wavelength ground wire and ground stakes at both ends of the ground wire: 5MVM at 1 mile distance which equals 18 percent efficiency as compared to the Standard 1/4 wavelength vertical tower with 120 ground radials.
2. 20 foot mast, series fed and tuned to resonance using the same ground system as shown above: 1.44 MVM at 1 mile or 5.2 percent efficiency.
3. 20 foot mast antenna, series fed, with a 20 X 20 foot ground screen beneath, isolated from earth ground: .2 MVM at 1 mile or .72 percent efficiency.
4. 20 foot mast antenna, series fed, with a single .1 wavelength counterpoise, isolated from earth ground: 1 MVM at 1 mile or 3.6 percent efficiency.

20 FOOT HELICAL  
OR "FOLDED - LOOP"

1. Same antenna as above, except a wire "folds back" from the top to the bottom or is wound around the base or center as a loading device, using a series capacitor as a tuning device to a single 1/4 wavelength ground radial: 10 MICRO VOLTS per meter at 1 mile or very low radiation characteristic.
2. Same as above, but tuned to resonance with a series coil and capacitor, using a 1/4 wavelength ground radial over marshy soil: 100 MICRO VOLTS PER METER at 1 mile or .36 percent efficiency.

NOTE: This "folded" Design gives far less efficiency than a straight mast or whip antenna, but is very useful for "controlled low level radiation" such as is required in part 15 Regulations for limited area broadcasting.

EFFECTS OF EXTRA GROUND RADIALS  
FOR WIRE AND SUB STANDARD ANTENNAS  
AT STANDARD BROADCAST FREQUENCIES

by

James R. Cunningham

1. Horizontal wires, end fed and tuned to resonance demonstrate an increase in signal strength as ground radials are increased in number. A given field strength with a single ground radial running directly beneath the elevated Antenna Wire shows the following:

A. There will be an expected increase in Signal Strength (MVM at a given point) of 1.47 Times the first measurement (with a single GND.) for each increase of 20 Radials. These measurements are valid for use with Ground Stakes and  $1/4\lambda$  wires.

B. Each time another 20 Ground Radials is added, the signal strength will increase 1.47 times the former reading.

Tests hold true for horizontal wires, very short whips, poles, and other smaller type vertical masts under .1 wavelength.

The length of Antenna Wire, or vertical mast should first be decided; then the known signal strength may be increased according to the above calculations by adding ground radials in sets of 20's.

These calculations are not valid for Towers in excess of .1 wavelength and apply especially for horizontal wires and small masts.

Note: All tests were conducted over "marshy wet soil" with a conductivity of 30, in the years 1993 through 1997 by J.R. Cunningham; FCC Lic. # PG 10-2117 using RCA Field Strength Meter Type WX-2C.

TYPICAL OPERATION

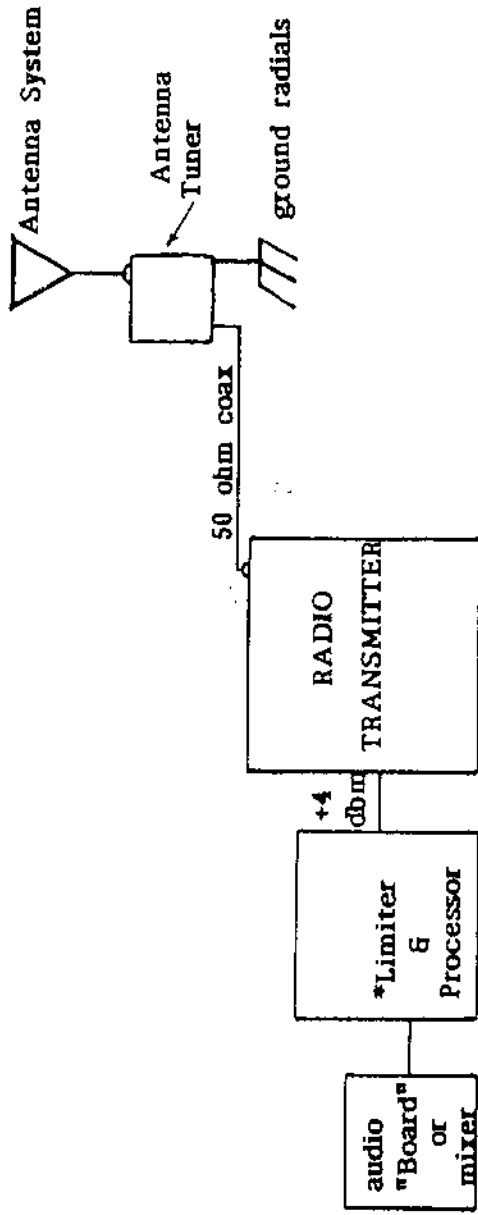

Limiter is required by the FCC for use in the USA

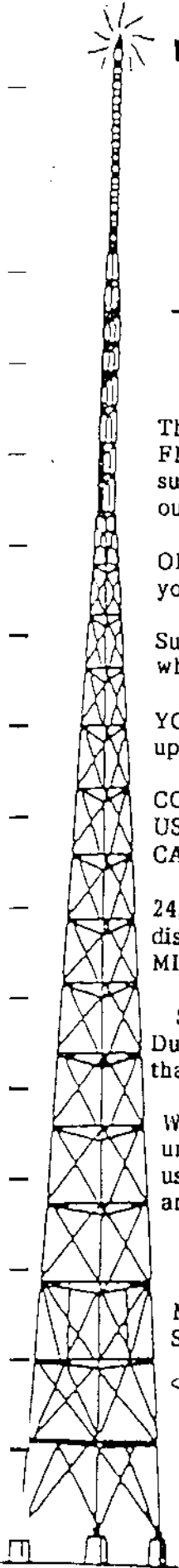

*Southeastern*

# TECHNICAL SERVICES

BROADCAST

RADIO

MISSIONS

JAMES R. CUNNINGHAM, Broadcast Engineer

P.O. Box 8, Stonewall, OK 74871

(580)265-4496

## IMPORTANT NOTICE

The FCC allows neighborhood broadcasters only 100 MW of Power for either AM or FM Radio Frequencies. This is limited to an antenna of only 10 feet and it is supposed to be connected directly to the back of the Transmitter - no coax going out to an external antenna.

OBVIOUSLY, this represents a handheld Unit, such as the toy walkie-talkies sold in your local toy store!

Such limited restrictions do not meet the needs of the COLLEGE CAMPUS STATION, which is A MODEL (according to Part 15 of the Rules/FCC).

YOUR EQUIPMENT IS SOLD AS A COLLEGE CAMPUS BROADCAST STATION. It is up to you to seek out and find ways to Broadcast Legally.

COLLEGE CAMPUS EQUIPMENT MAY BE OF ANY POWER. ANY ANTENNA MAY BE USED. COAX LEADING TO SEVERAL ANTENNAS IS PERMISSIBLE. OUTSIDE THE CAMPUS GROUNDS, the Field Strength must be measured and must comply to:

24,000/fkHz or 24,000 divided by frequency in KILOhertz. This is measured at a distance of 30 meters from the edge of the Campus. The result is measured in MICROVOLTS PER METER (Section 15.209 FCC Rules).

Since the College Station is allowed more freedom and more power, it also has a Duty to check radiation strength, harmonics, etc. and to keep everything in order so that violations do not occur.

We are not experts in FCC Rules, nor are we Lawyers; we have presented here our understanding of the Situation and in no way can be held responsible for the wrong use of Equipment, which was sold in good faith, in hopes that our Clients will obey any and all rules.

MANY HAPPY HOURS OF BROADCASTING WITH YOUR COLLEGE CAMPUS RADIO STATION EQUIPMENT!

*J.R. Cunningham*  
JR Cunningham  
Missions is our Business



# The Community Radio Station

Using the convenient  
"Community Broadcaster's Antenna"

Many smaller Communities have not had a Local Radio Station in the past due to problems with expensive Equipment, and Technical Problems. Now, every Community may have it's own Station without danger of interfering with the higher powered Stations which operate at Regional or National Levels.



**CM 30 - 50 AM Transmitter**

This is made possible using the modest 50 Watt Tube Type Transmitter pictured here in connection with this special Whip Antenna System made especially for AM Radio.



**Community Antenna System**

## HOW IT WORKS

First, the Transmitter is fully adjustable to any power between 2 Watts and 50 Watts, which allows for just the right coverage as specified by Engineering Studies. The Transmitter Power can be fixed at this position by adding proper Biasing Resistors internally, which allows for plus or minus 5-10 percent correction using the Control on the Front Panel of the Equipment.

Next, the Whip Antenna System is perfect for Community Broadcasting under Low Power Conditions.

## This is why it works

The Whip Antenna is mounted at a height of 8-10 Meters above ground level. Since the Whip is short (about 2 Meters) and is tuned to resonance, it radiates almost no signal at Broadcast Frequencies. The Whip is used as a tuning device, and high angle radiation is virtually eliminated because the lower "ground" wire is forced to do all the work. Since the Ground Wire is Vertical, as it descends from the Tuning Box, this Wire provides a low angle Radio Wave of modest Signal Strength. This wire must be put inside a plastic PVC Pipe if a metal Tower or Pole is not used as the Vertical Ground Element. Beneath the Mounting Pole, about 10 (20 M. long) buried Ground wires assist in carrying the Ground Wave along the earth and also provide lightning protection.

Low angle Radiation characteristics make this Antenna Method very practical in this application, along with the ability to completely control the Power into the System.

This 50 Watt System will adjust for good coverage from 1-2 KM all the way to 15 KM when using full Power and maximum Antenna Height.

This Antenna System can be mounted at roof top level using a tripod mount or a pole, or it may be mounted on a power pole or other structure. Increasing height aids in increasing Signal Strength. This should be adjusted according to the needs of the Community.

James Cunningham  
Broadcast Engineer

# ROOF TOP ANTENNA SYSTEM

For AM Radio

Campus Radio  
Installation Example

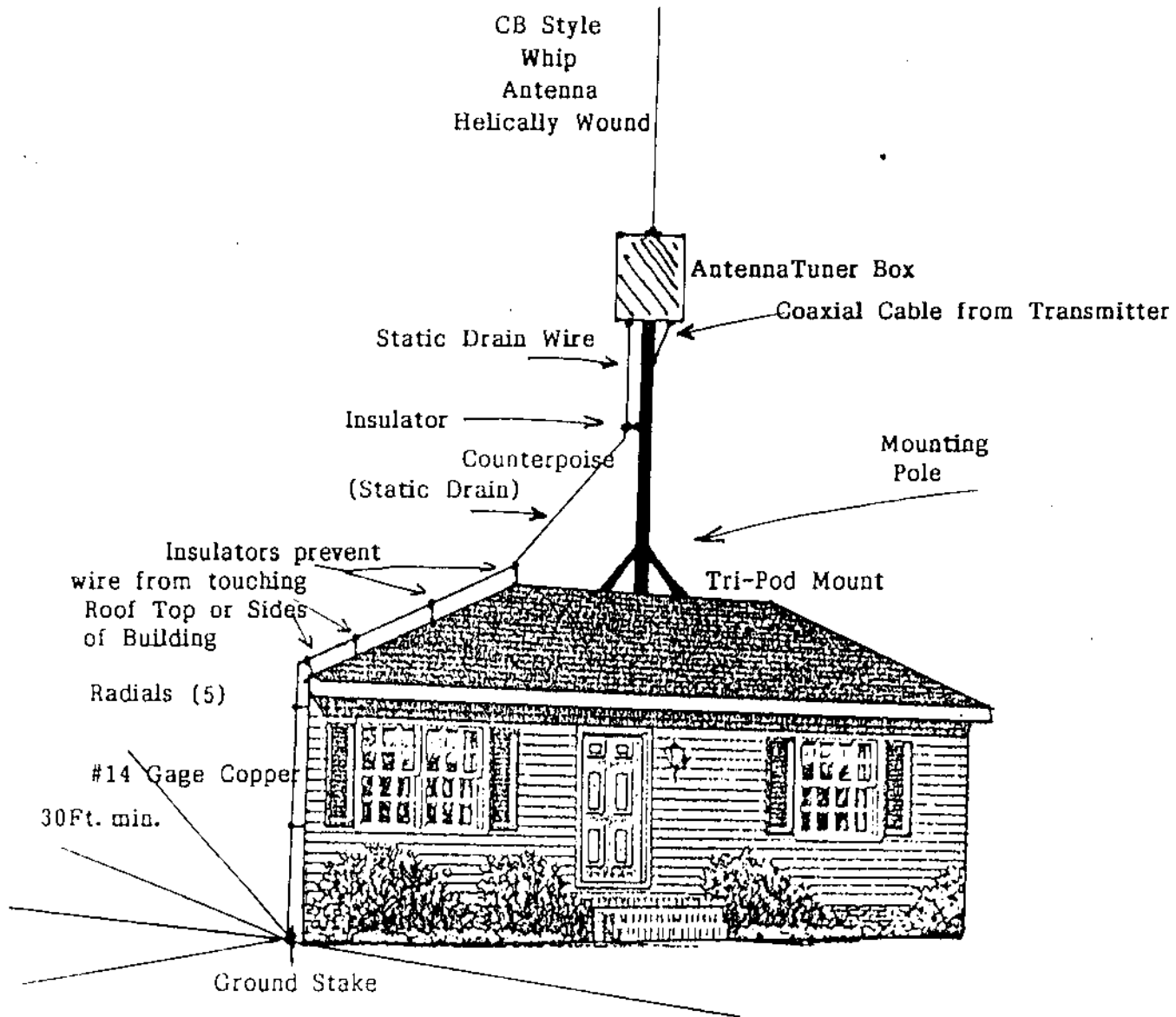

Notes: The System is tuned to "Resonance" using the Tuner Box. The Whip Antenna "Resonates" against the "Static Drain or Counterpoise." This gives a Low Angle Radiation Characteristic for the AM Signal. The Whip Antenna must be up as high as possible, making the "Counterpoise" at least 40 - 50 feet in length. If the Counterpoise is not long enough, the System will not work well. All Radials must be bare copper wire. Size or Gage is non-critical.

## ROOF TOP ANTENNA SYSTEM

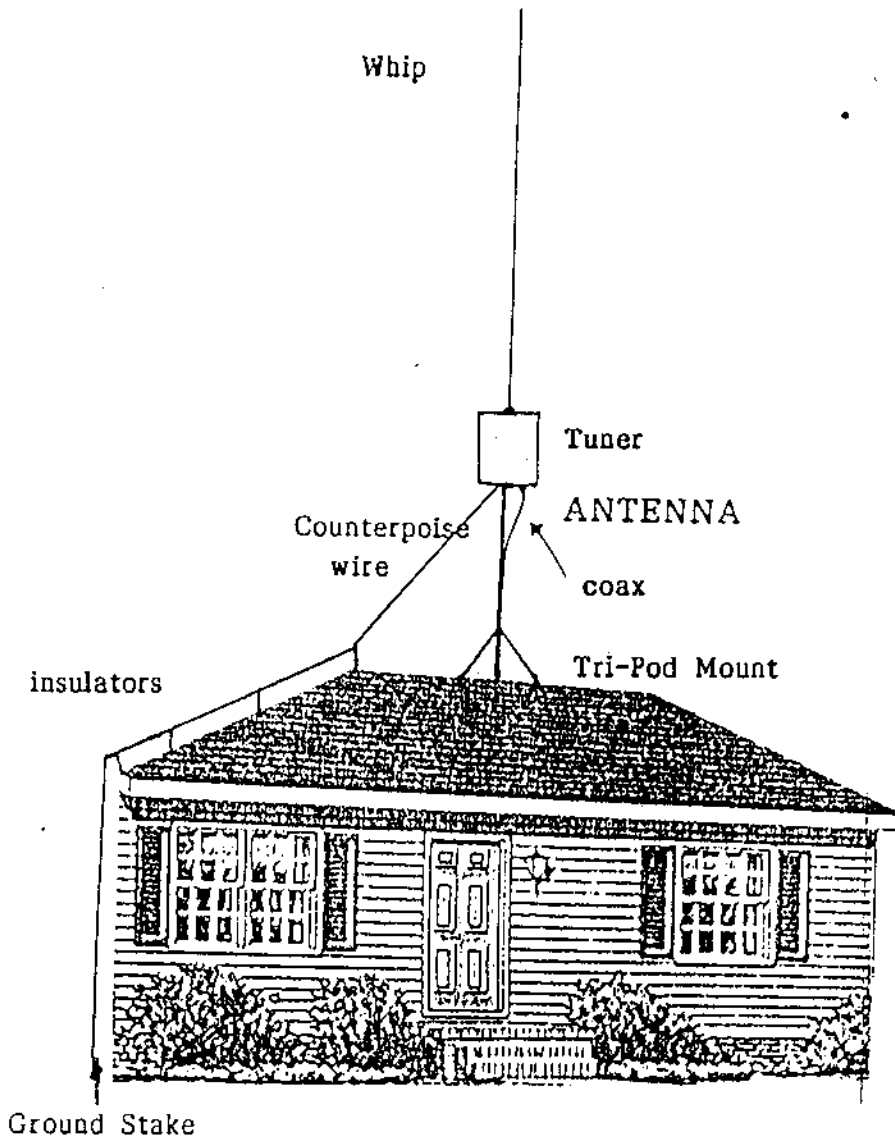

Notice that the Counterpoise "Static Drain" Wire is insulated from the Pole, from the roof top, or from any other objects. If used with a metal Mast, this wire works best when kept as far from the Mast as possible (except in cases of a metal Mast or Tower in excess of 40 feet).

VERIFICATION FORM  
FOR  
A.M. BROADCAST STATION  
ON COLLEGE OR UNIVERSITY CAMPUS  
FCC RULES AND REGS. PART 15.221  
SECTIONS (a) THROUGH (d)

FILL IN THE FOLLOWING:

DATE: \_\_\_\_\_

1. Transmitter Type \_\_\_\_\_  
home made, Brand, Model, I.D. Number, etc.
2. Antenna(s) in use: \_\_\_\_\_  
Wire, Vertical Whip, etc. (description)
3. Height above Ground Level of each Antenna: \_\_\_\_\_  
List only information pertaining to  
this AM System (exclude FM, CB, Cellular, etc.)

POWER AND FIELD STRENGTH INFORMATION

- A. Transmitter Power into Antenna(s) \_\_\_\_\_  
The FCC encourages as little as needed to  
cover the College Campus - Typically 10 Watts for AM Broadcast Stations
- B. Field Strength as Measured 30 Meters Outside Campus: \_\_\_\_\_
- C. Field Strength at 1 Mile: \_\_\_\_\_  
Optional
- D. HARMONICS DETECTED: \_\_\_\_\_  
Check with a General Coverage Receiver at - 30 Meters
- E. Modulation Percent: \_\_\_\_\_  
125% Max. (Measure with Oscilloscope or Mod. Monitor)

F. OTHER PERTINENT DATA:

DATE: \_\_\_\_\_ TIME OF DAY READINGS WERE TAKEN: \_\_\_\_\_

LIST TYPE, MODEL AND SERIAL NUMBERS OF TEST EQPT.: \_\_\_\_\_

Person doing Tests: \_\_\_\_\_ FCC LIC. No. \_\_\_\_\_  
Signature If applicable

INSTRUCTIONS FOR ANTENNA  
COLLEGE CAMPUS SYSTEMS

Limit to Field Strength  
(Applies to Campus Systems only)

Rules - Part 15:

Field Strength must be "measured"  
30 Meters outside Campus Area  
Average Strength is 15 MICRO Volts P/M  
FORMULA:  $24,000/\text{Freq. in KILO Hertz}$   
gives Field Strength in MICRO Volts

INSTRUCTIONS:

1. Pole or Mast can be either wood or metal; but TOP OF MAST MUST BE AT LEAST 30 - 40 feet above ground level for proper operation.
  2. LOADING COIL BOX is mounted with clamps on metal pole or SCREWS on Wood Poles.
  3. GROUND WIRE can be a bare wire or covered - bare is best. (CONNECT TO "GROUND LUG" ON BOTTOM OF BOX AND BRING IT ALL THE WAY DOWN THE POLE, AND DOWN TO A GROUND Stake. NEVER GROUND IT TO A ROOF FLASHING OR VENT PIPE! (Without this ground wire, LIGHTNING may damage the System/Transmitter.)
  4. The Ground Wire is necessary for correct Signal Propagation and Listener Coverage.
  5. WHIP ANTENNA - 4 feet is all that is needed for this System to work, but 8 feet is better. A longer Antenna is NOT recommended for best operation. This System relies on ANTENNA POLE HEIGHT for best coverage!
  6. COAX is usually RG-58U for Campus Stations. Transmitter Power is normally LIMITED to 10 Watts or so in order to avoid Harmonics and Illegal Operation. COAX should be at least 50 feet in length to provide MAXIMUM SEPARATION between Antenna and Transmitter Equipment.
- If Antenna is too close to Transmitter, RF Feedback may RUIN your Audio Quality.
7. Guy Wires are not shown in the Drawing. Guy wires should not interfere with normal operation.
  8. IMPORTANT NOTE: If a wood Pole is used, Ground Wire may be enclosed in a 3/4 inch dia. PVC Pipe for best operation. If Metal Pole is used, tape or tie Ground Wire to Pole for security against high wind damage.

NOTE:

Measure A.M. Field Strength with FCC Approved Type Field Strength Meters only for accuracy.

PART 15 FCC Rules  
For Low Power Part 15 Stations  
AM and FM

1. Part 15 applies to Individuals as well as Educational and Correctional Facilities.

BASIC REQUIREMENTS

- A. No harmful interference to Licensed Government or Commercial Stations. Based on Part 15 Rules Part 15 3:M and other Part 15 notations.
- B. CORRECTION OF HARMFUL INTERFERENCE - When notified by the FCC of harmful interference, the Operator of the Equipment must correct the problem or cease operations until the problem is fixed. (Part 15, 5:C). FCC 47CFR Ch. 1-93 Edition.
- C. The FCC no longer goes by what kind of Transmitters, how many antennas, or by the Equipment Certification (or lack of Certification), but by Harmful Emissions as stated above and (2) by FIELD STRENGTH LIMITS.

UNLICENSED FIELD STRENGTH LIMITS

(for unlicensed Campus, Institutional and Educational)  
and  
for private operators of unlicensed Broadcasting

D. FIELD STRENGTH LIMITS

Field Strength Limits for FM RADIO are stated in Part 15, 209:A and amount to 150 MICRO VOLTS at a distance of 3 Meters or 10 feet from the Antenna. For Campus and other Institutional Unlicensed Stations, these limits are measured at that distance OUTSIDE the Property of the Campus. There is no Limit to Field Strength INSIDE the Institution. Part 15, 221:B.

AM RADIO UNDER PART 15

AM Radio is allowed more field strength than FM, and the same Rules regarding Harmonic Interference apply. FIELD STRENGTH is calculated using the Table given in 15:203. The FORMULA for AM Field Strength is  $24,000/F$  Kilohertz. The Field Strength is measured at 100 feet or 30 Meters OUTSIDE the Campus Grounds.

E. Install Equipment with as many Transmitters and Antennas as needed to cover the Campus. Then, adjust the Power to comply with Field Strength Requirements as stated in Part 15 Rules and Regulations.

## APPLYING FOR A RADIO STATION LICENSE

The first thing you need is LOCATION. Before a Station can be built or applied for, a Tower Location is needed. This is required by the Consultant to be within a few hundred feet of the Final Location. This is used as a point of reference in the Computer Program that checks for the availability of an available Frequency.

### FREQUENCY SEARCH

You will pay the Consultant for a FREQUENCY SEARCH using the Antenna Location you decide upon. This is called the FM ALLOCATION STUDY. The results of this Study will be a Computer Printout showing the various Frequencies by Channel Numbers. Beside this Channel Number will be the word "SHORT" or showing a "plus" sign. "Short" means short spaced, and you can not use that frequency, except when a lower power can be applied for, as in the case of many non commercial Applications. The Consultant will recommend what to do, as you talk over the papers with him, asking questions.

The Print Out will also show the CALL LETTERS and LOCATIONS of existing Stations, their Antenna Heights, powers, and Bearing Data.

### POWER OF THE SEARCH

Most "Searches" are done for 3000 Watts Power. A Channel that shows "Short Spacing" by only a few Kilometers, can possibly be used at say, 1000 Watts. If the Tower Location is very close to the Coverage Area, it would be better to have 1000 Watts close by, than 3,000 Watts 10 or 20 Miles away. The Signal Strength over the Coverage Area would be the same, but by using less power, the Electric Bill and other Equipment costs would be greatly reduced.

### THE APPLICATION

Once you locate a Frequency at your LOCATION, and a power to apply for, you File the FCC Application including any Fees. The Application is provided by the Consultant along with Maps and other Info. required by The FCC. It now takes about 9-12 months to get the CONSTRUCTION PERMIT, allowing about 18 Months to build.



# Methods of sending a signal

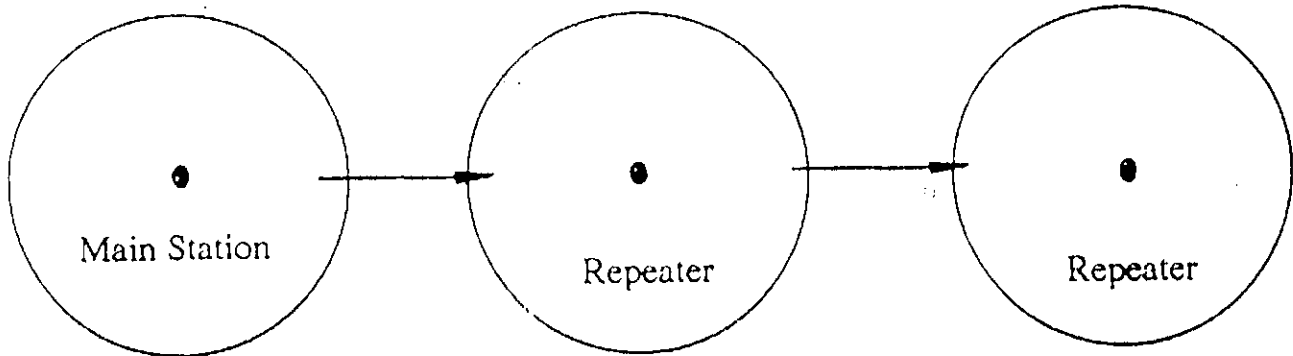
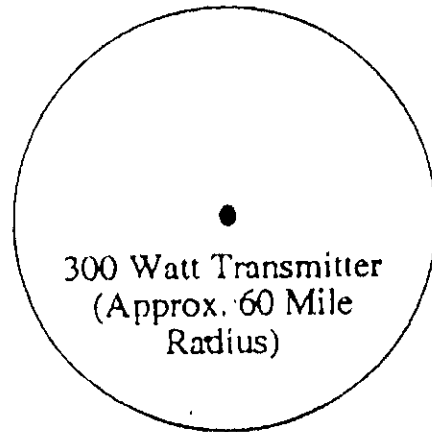
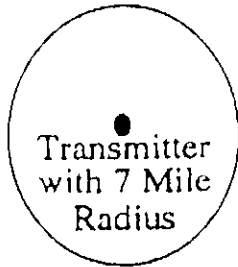

Transmitter with repeater stations across a country

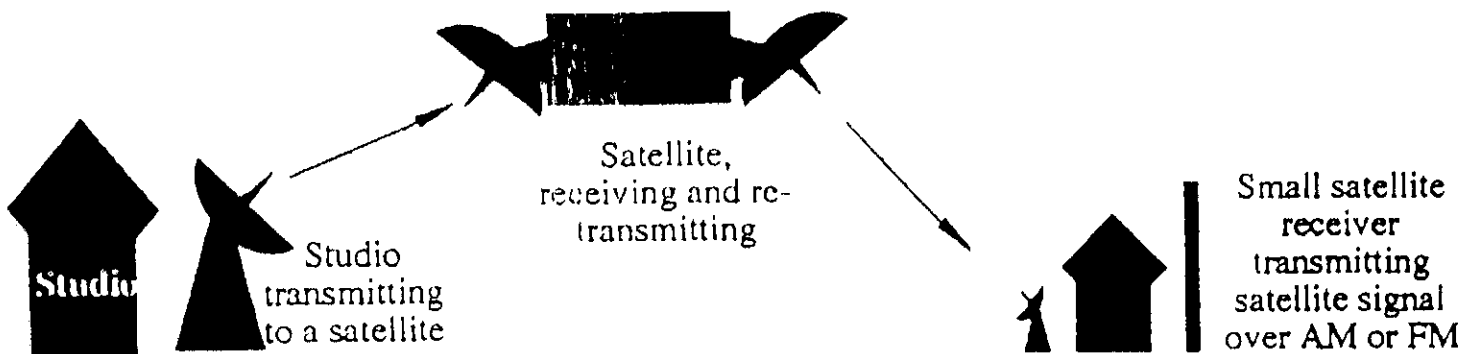
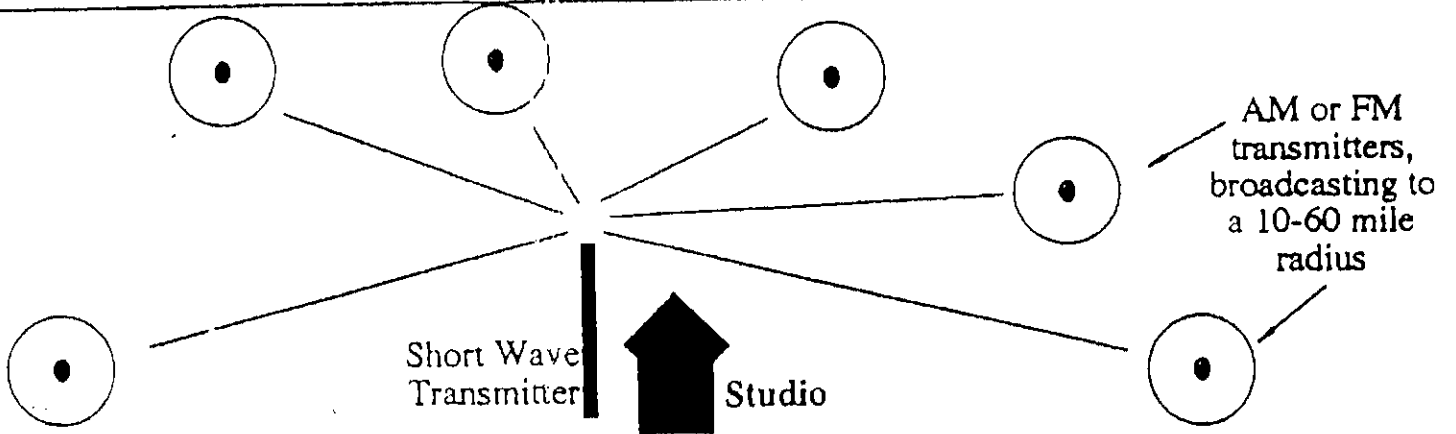

# The "PLUG & PLAY" Antenna

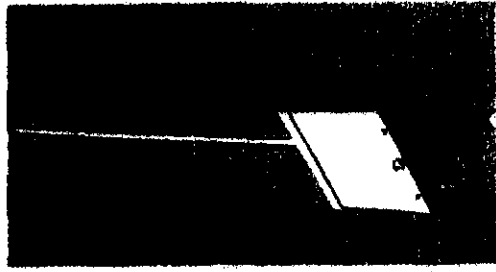
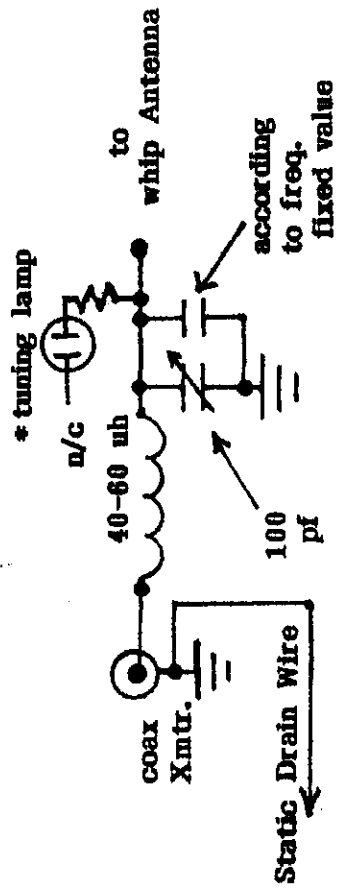

This Antenna has built in tuning. Just place it high up on a pole over a top or in an open place, run the "static Drain" wire down to earth, connect coax, turn on Transmitter and you are "ON THE AIR"

**NOTE:**

- \* tuning lamp resistor - 270K/1/2 Watt

# TRADE SECRETS

## Of Carrier Current Tuning

The UNIVERSAL TUNER allows for tuning into the In-House Power Lines, with an RF Signal. This can allow a great deal of coverage, but the least amount of mis-match can show up as RF INTERFERENCE, especially to Radio and TV reception.

To explain this, let us look at the following math, since Power equals Amps Squared Times Resistance.

A Typical Load in the House Wiring could be as low as .01 Ohms. If just 10 Watts of Power is run into this Load, using correct Tuning, the Math works out to the tremendous current of 31.6 Amps! Most in-House Wiring is capable of about 15-20 Amps, so this is going to present problems with heat and Interference. If 50 Watts were fed into this same Load, we have the huge amount of 70 Amps of RF trying to circulate around in wiring made for about 1/4 of this value! No wonder we are having problems getting our Signal to do what we want it to do! It would require a big reduction in power to use such a low Resistance Load, and that is SELF DEFEATING!

### SOLVE THE PROBLEM

In order to solve this problem, we need to INCREASE the Resistance of our Load. If we can increase the resistance of the In-House Wiring Load to .1 Ohm, we have brought RF Current down to a safe 10 Amps, and we still have a full 10 Watts of Power going into the Wiring!

### Keep It Simple

The easy way to increase this Load Resistance to an acceptable Value, is to separate the Feed Point from the Ground by a number of Feet.

On the Universal Tuner Box, there is a Ground Lug on the Bottom of The Box, and a Hot Wire on Top. The Ground will still connect at the Service Entrance, but we must use an increased length of GROUND WIRE. The Hot wire will remain very short, and placed so that it allows for more footage of In-House Wire for the Signal to work with, by using another receptacle at a distance from the first location.

It may be necessary to connect the RF Plug into an upstairs or basement outlet, in order to get the desired results. This means carrying the Tuner Box all the way to the Feed Point, and running a Ground Wire all the way back to the Service Entrance Ground! This ground wire must not touch other grounds or metal objects. Place it inside a PVC Pipe where practical.

Carrier Current is not an exact Science, so keep trying until you get it right. Below is a list containing nearly ideal 1/4 Wave Length wires for a good match in Tuning, listed according to Frequencies.

If your Frequency is close to the listed Frequency, an ideal length of interior Wiring would be as shown. This is not critical and can be estimated.

500 KHZ - 425 Feet

600 KHZ - 390 Feet

800 KHZ - 292 Feet

1000 KHZ - 230 Feet

— 1400 KHZ - 167 Feet

— 1500 KHZ - 150 Feet

— 1600 KHZ - 140 Feet

— 1700 KHZ - 130 Feet

— Once the Signal Wave Form is "set up" inside the In-House Wiring, it will travel along those wires as long as there is continuity. That's why we prefer Tuning to "The Neutral" Wire, so that Transformers, sub stations, and Homes do not stop our Signal Dead Cold! In some areas, there is so much Interference from Neon Lights, Transformers, and Businesses, that Carrier Current will not work at all. In MOST non-congested neighborhoods, it works quite well.

— However, IF POWER LINES ARE BURIED, YOU CAN FORGET ABOUT USING CARRIER CURRENT. It will reach about 1/3 of the way down the block, according to our Tests, when the Lines are buried.

— Avoid large amounts of RF Power running into the Power Lines as it may ruin the Tuner, The Transmitter and even cause a fire - not to mention the large amounts of RFI it will most certainly generate! And THAT will cause problems with neighbors and the FCC!

# BROADCAST PROBLEMS

Operating an AM Station is quite different than doing FM, especially when using Eqpt. designed for Economy Operations. This often involves using semi-professional Mixers, Players, and Recording Equipment which can malfunction in a high RF environment such as when used in close proximity to Exciter/Transmitters, and Antenna Systems. Static, Distortion, Hum, Drop Outs, and "funny noises" can originate from such installations, which seldom have sufficient Internal Shielding and fail to use "Professional Balanced Line" Wiring Methods.

FM is usually just "Plug and Play" and is easier to make work. There are exceptions to this, especially when operating the Audio Eqpt. too close to the Antennas! I have known Missionaries who tried to operate a 300 Watt FM Station with the Antenna just 6 feet away from their Audio Mixer! This turned out to be a disaster in FEEDBACK, distortion and TVI (Interference). Because the System would not operate like this, they became discouraged and quit Radio completely! How foolish to think that a Broadcast System could possibly operate in such a manner, but they seemed to think they could do it even after being warned beforehand.

Now, AM Radio is not intended to operate this way either, with the Transmitter just a few feet away from the Audio Equipment or Antenna; yet MOST Low Power AM Broadcasters insist on this same foolish Procedure. AM Feedback is FAR WORSE and harder to deal with than FM!

## RULES TO FOLLOW

1. Separate your Transmitter as far as practical from the Mixer and Audio Eqpt. This should be 15 - 25 feet where possible. If NOT, you can deal with Feedback by using (a) Balanced Lines for all Audio, (b) Ferrite RFI Filters on all Audio Lines, and (c) high quality Professional Type Studio Equipment throughout the Facility. GROUND all Equipment through the Station Ground. (I will cover this later).
2. Put the Antenna Tower Base at least 50 feet from the Transmitter Location using plenty of high quality Transmission Line to carry the RF to the Antenna, and use the right Antenna for the job! Never put the Studios directly beneath the Antennas if Broadcasting with more than 100 Watts of Power!
3. BE SURE the Antenna is tuned to your Frequency, and you can not use an antenna designed for 50 watts with a 300 or 500 Watt Signal. There will be problems with Distortion, High SWR, (Interference), Feedback into phone lines, and even smoke and FIRE! Be careful!

## TECHNICAL PROBLEMS

The worse Technical Problems are caused by improper Antenna Procedures. This may consist of the following:

1. The Wrong Antenna for the job. This is the most common with AM Broadcasters. Missionaries usually do not have enough land or funds to put up a full size AM Tower with the associated Ground System. They will resort to very foolish practices, such as trying to load a small piece of copper pipe with a huge Loading Coil. It won't work well, but it will burn out the Loading Coil, (and perhaps cause a fire) especially when driven with several Hundred Watts of Power - not to mention the harmonics and TVI coming from their Antenna. Aircraft Communications have been blocked by just such a set up! See the Notes below for "A BETTER MISSIONARY AM ANTENNA."
2. There are practical limits to the short Vertical Whip "Plug and Play" Antenna System I recommend for Campus Radio Stations. The Power Limit is 10 Watts. At 50 -100 Watts, this System generates a lot of Harmonic Content. It has been used, but the phone lines malfunction, the TVI is bad, and most of the time, the Audio becomes Distorted!

### WHY SO?

As the Power into this Antenna System is increased, the SWR rises exponentially (straight up)! This is so because, at higher Powers, addition CURRENTS flow in the System. The short whip and ground is not long enough, the Antenna is not LARGE enough to accommodate the EXTRA Currents associated with the extra Powers. If the NUMBER of Ground Radials is radically INCREASED, along with the SIZE of the CONDUCTORS by using COPPER STRAP tying all the Radials together, it will very effectively lower the SWR and permit a higher Power Tolerance. The LENGTH of these Ground wires MUST be at least 1/4 wavelength to be correct, but wires of 75 feet long work quite well IF THERE IS WET SOIL covering the Ground System, and there are quite a few of these wires. If such an Antenna can not be radically improved, then POWER into the System must be radically REDUCED!

### \*\*A BETTER MISSIONARY AM ANTENNA SET UP

By a Missionary AM Antenna Setup, I am referring to an Antenna that will operate in a very tight space, where there is insufficient space available for a normal Tower. A nice set up would be to have a wire antenna on 20 foot high poles. There would be a total of 4 poles, with the wire at the top suspended on 4 Insulators. The total length is 150 feet for frequencies 1500KHZ. to 1700KHZ. The length will increase for lower frequencies according to the formula:  $234/f\text{mhz}$ . The wire is brought down on 1 end only. The ends are separated from each other. The wire that comes down attaches to the ANTENNA TUNER, which is at ground level and close to pole one. If these 4 poles are set up on a high Roof Top (or between several Roof Tops), the results are even better.

The GROUND SYSTEM is below the poles and goes out in every direction. When cramped for

space, 5 radials may be used of 150 feet length unless the ground is VERY WET, then shorter lengths can be used where a very small lot is all the land available. In this case, drill a well and place a large Copper Strap (at least 2 inches wide) down the well until it touches the water. I am speaking of a Technique that has been proven to work. This vertical ground is effective if the well is at least 150 feet deep. It will help at less depth if there is water in the well.

WARNING: Even this set up will not operate well if there are large metal objects within 100 feet of the Antenna such as BUILDINGS, BARNS, LARGE POWER LINES OR even Sea Water. Sea Water is a very good conductor and the signal will go out over the water instead over the land!

#### THE FOLDED UNIPOLE OR MONOPOLE

The folded unipole antenna is a short tower with its Base grounded to the Ground System. Going up the sides are 2 or 3 wires isolated from the metal Tower and grounding to the Tower farther up. These wires are connected together near the bottom and connected to the Antenna Tuner. The whole thing is tuned up and works as well as having a much higher Tower.

This set up also has its limitations. Generally, this Tower must be over 1/8 Wavelength to work at all! Usually this means about 75 to 90 feet for a usable Folded Unipole at 1500 - 1700 KHZ Frequencies. Shorter Folded Unipoles have been tried, but if they are mounted at Ground level, even with an excellent Ground System, they function poorly. If the same short folded Unipole is placed high above the Ground, such as on a high Roof Top (more than 5 stories above the ground level) then the signal does very well due to the height.

The Folded Unipole that sets on the ground needs extra height, so that the part farthest up (above where the wires connect to the Tower) can be used as Top Loading, which increases its effectiveness.

A High Fidelity transformer that has 600 Ohm to 600 Ohm Windings (or a similar Transformer with similar values) can solve many problems inside the Studios. If one of these Transformers is placed in line with each feed to the Mixer, the RF Feedback can usually be solved. The Mixer is grounded to the Station Ground System, but the incoming Audio is isolated using the Transformers. The Telephones act up when newer type Phones are used in a high RF Environment. Most Newer Type Telephones do not have protection against RF. The Older AT&T Type Phones work best or special devices from the Phone Company can be installed inside their Desk Type Phones. If all else fails to get the RF out of the Phones (as a last resort only) place a .01 mfd. capacitor from each of the 2 Phone Wires over to the Station Ground Wire. These are a standard item at Radio Shack stores. A small 18 Gage Ground Wire may have to be run from the Ground System outdoors and into the Studios, then around to the Mixer and any other piece of Equipment you wish to try grounding. Try grounding the troublesome item by loosening a metal screw in the back of the Equipment and attaching the small Ground Wire to the back of the item. If this helps solve the problem, then leave it there. If it does not help, then DO NOT USE IT.

#### Microphone Problems

Some Microphones will also be sensitive to hum pickup or RF Feedback. If this is the case, wire the Mike using a Balanced Wire instead of the cheaper Mike Cable it may have on it. Balanced Line (wire) is designed to cancel RF and Hum and should be used where possible. Keep wires short and if there is extra wire laying around, try coiling it up and tying it together. This often solves RF Feedback. If all else fails, replace the Mike with one that will work. It may be necessary to try several before finding the right one. Once you find the right type, stay with this type in other installations, and you will have fewer problems later on.

CONTROLLED CAMPUS  
ANTENNA SYSTEM

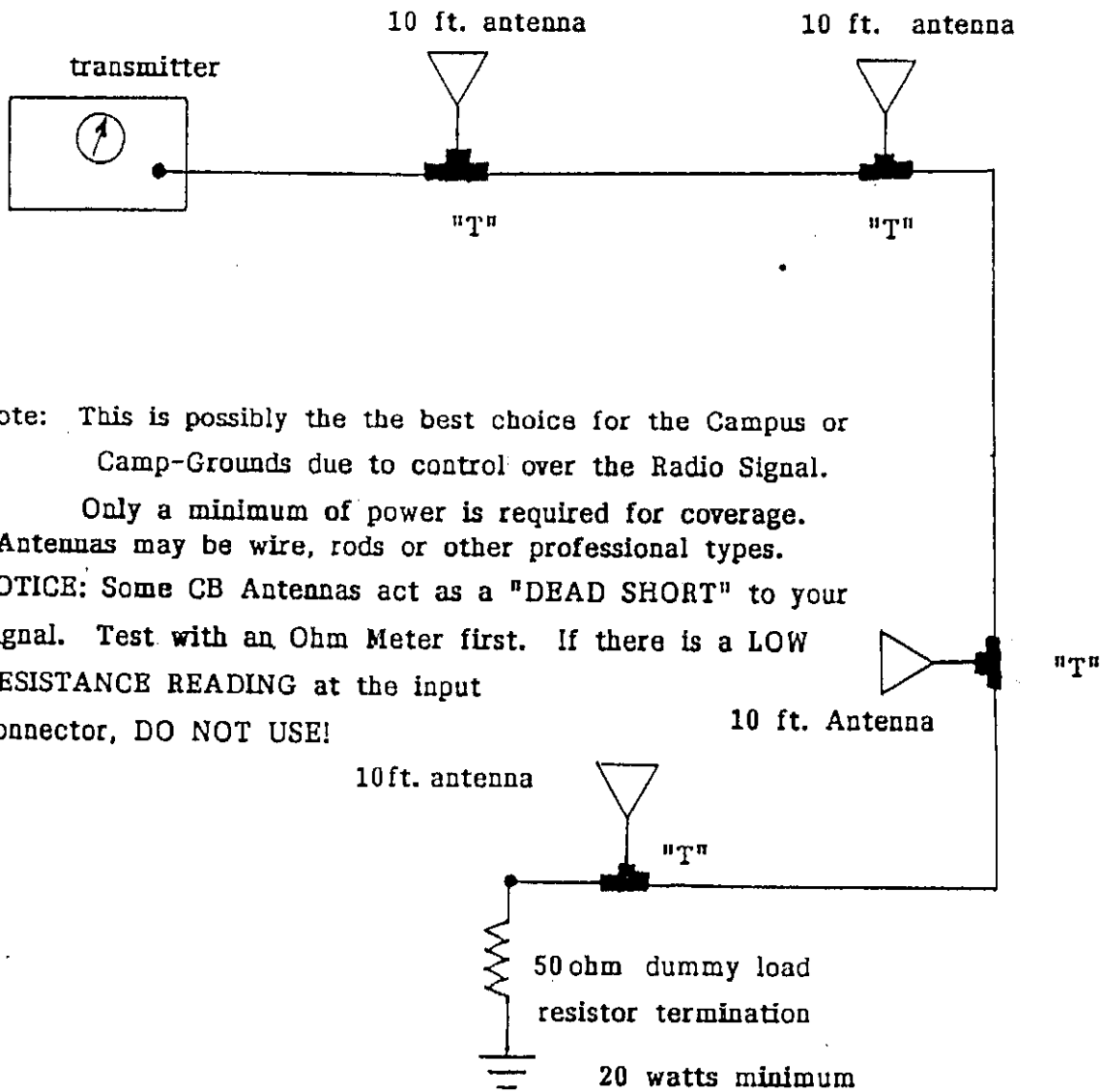

Note: This is possibly the the best choice for the Campus or Camp-Grounds due to control over the Radio Signal.

Only a minimum of power is required for coverage.

\* Antennas may be wire, rods or other professional types.

NOTICE: Some CB Antennas act as a "DEAD SHORT" to your Signal. Test with an Ohm Meter first. If there is a LOW RESISTANCE READING at the input connector, DO NOT USE!

THE SYSTEM

Every 50 to 100 feet, a "T" is placed in the RG-58U Coax and a ten foot antenna is set in place to provide enough coverage for the Campus. The resistor load at the very end of the coax is necessary to prevent distortion. Use as many ten foot antennas as is necessary to cover the Campus. [PARTS: "T" - Radio Shack #278-198, Coax - R.S. # 278-1326, Load - Heathkit #HN-31-A (1-800-253-0570) and end Connectors - Radio Shack # 278-188]. Place antennas out of reach.



LOW POWER RADIO ANTENNA

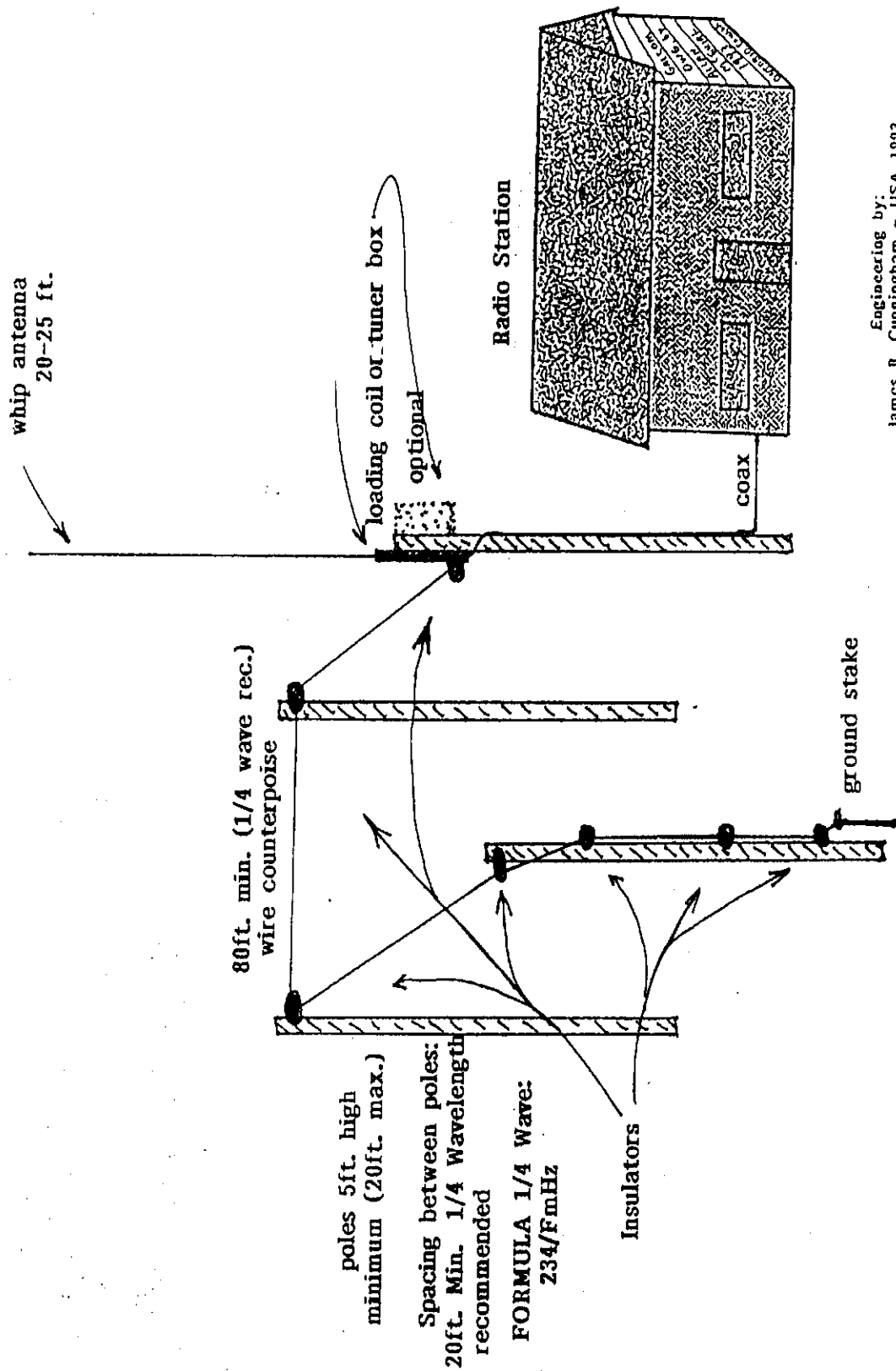

Engineering by:  
James R. Cunningham - USA 1993

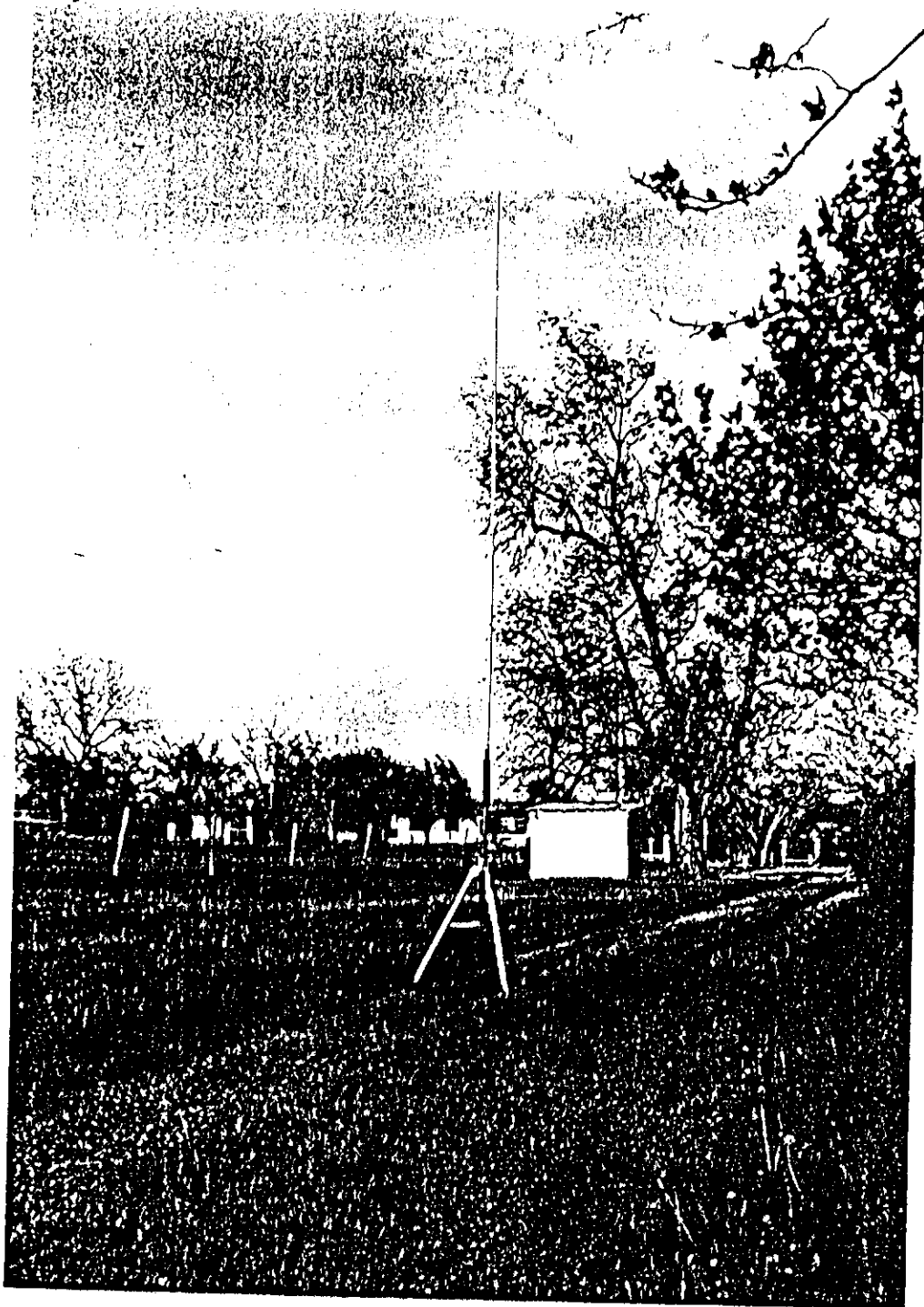

The 40 ft. Antenna with Tripod Mount

The Tripod Mount is set up on the top of a building, such as a house. The Tuner Box is placed on the bottom of the Mount. The "HOT WIRE" from the top of the Tuner Box goes to the METAL MAST. The GROUND WIRE from the bottom of the Box goes down to a ground stake. It is BEST to put as many ground wires on top of the roof as possible - this makes A GROUND PLANE. These wires must be 25 feet or longer. The ends of some of the wires will come down to the earth and connect to A GROUND STAKE. You can put several ground stakes on various sides of the building.

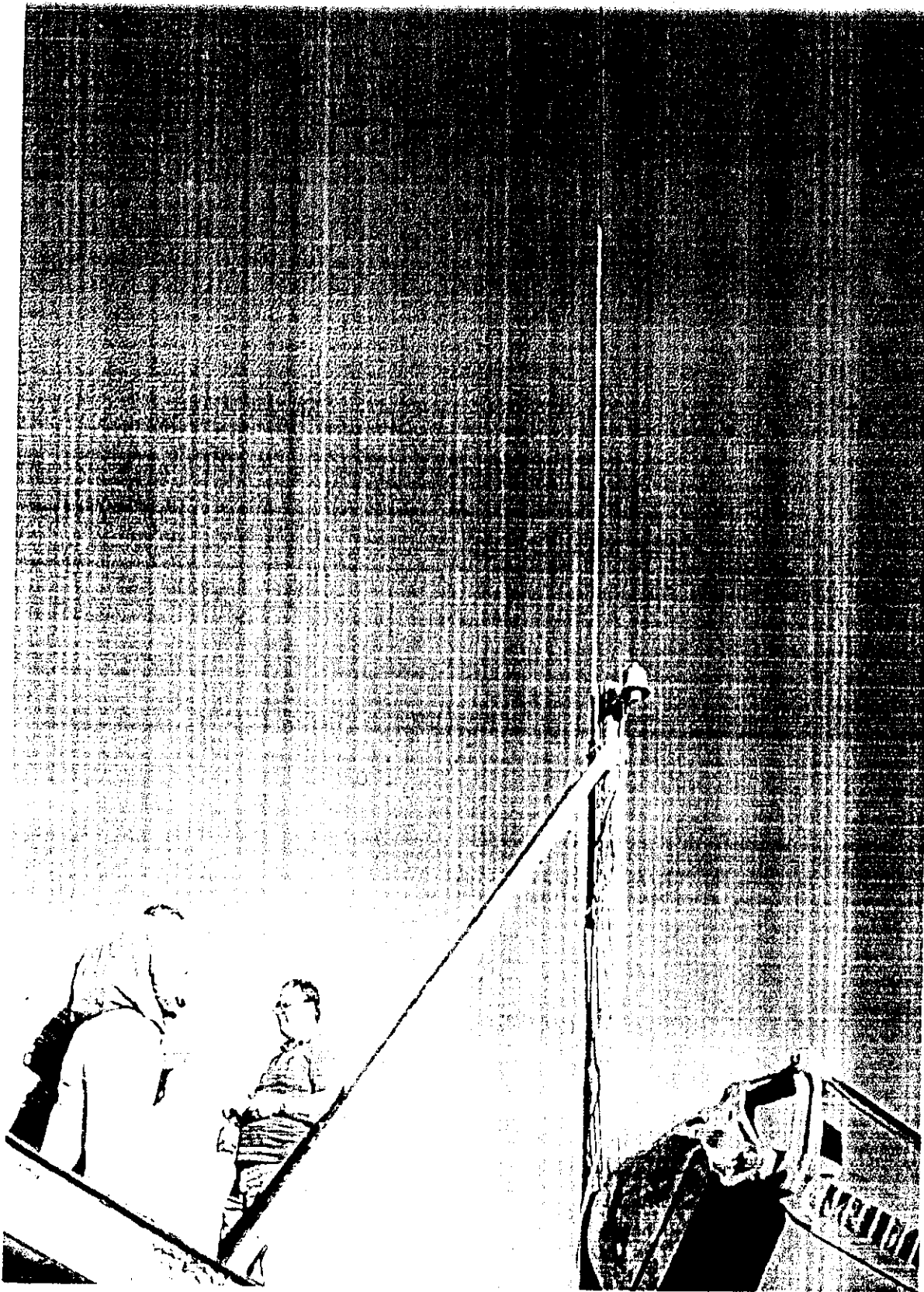

24 ft. Whip Antenna  
Mounted on a Light Pole

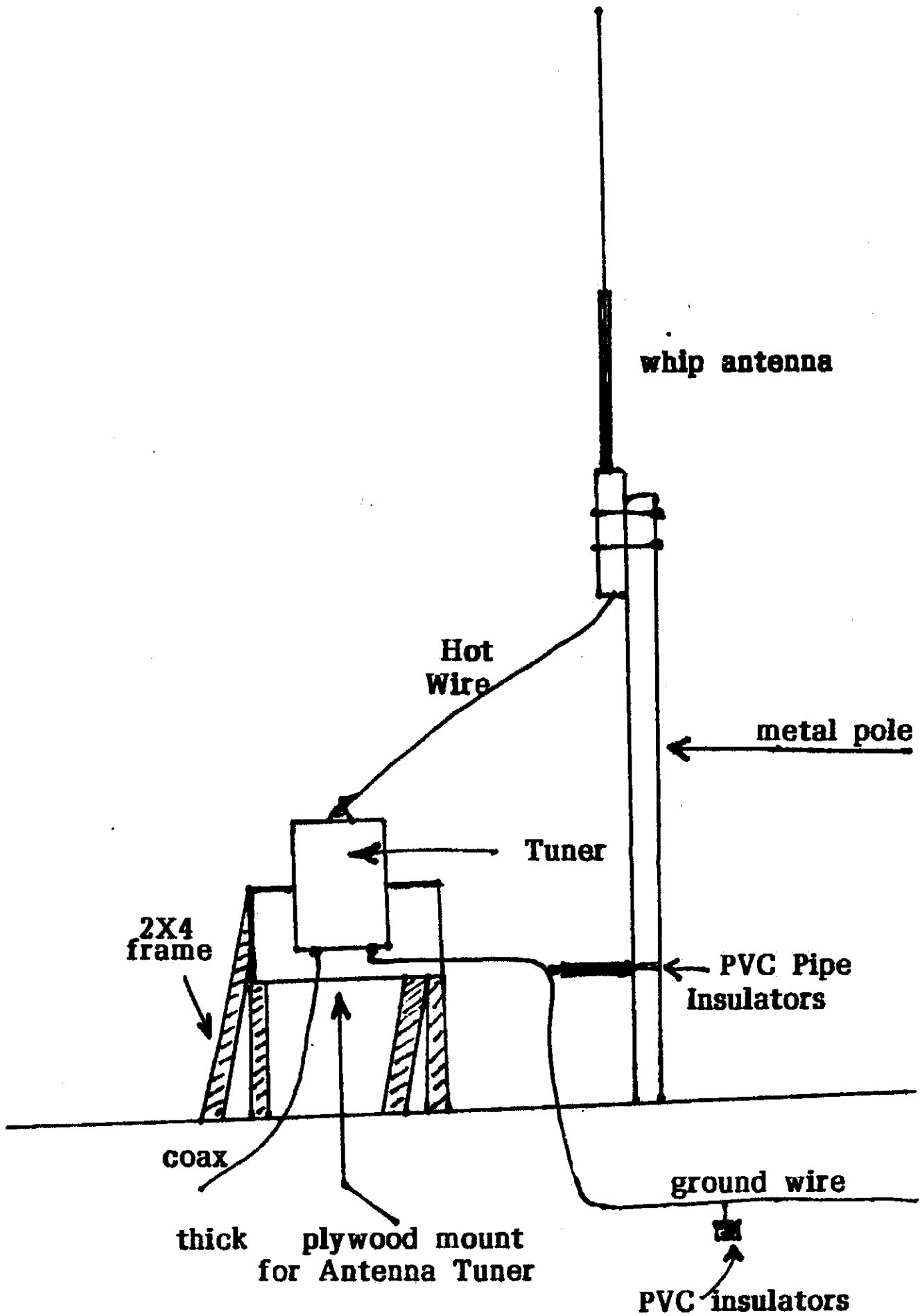

## Campus Radio Installation

### Example Number 2

Note: Tune the System to "Resonance" using the Tuner Box. Good for up to 150 Watts Power.

The higher the Pole, the better this will work. Low Angle Radiation comes from the Vertical "Counterpoise/Ground System".

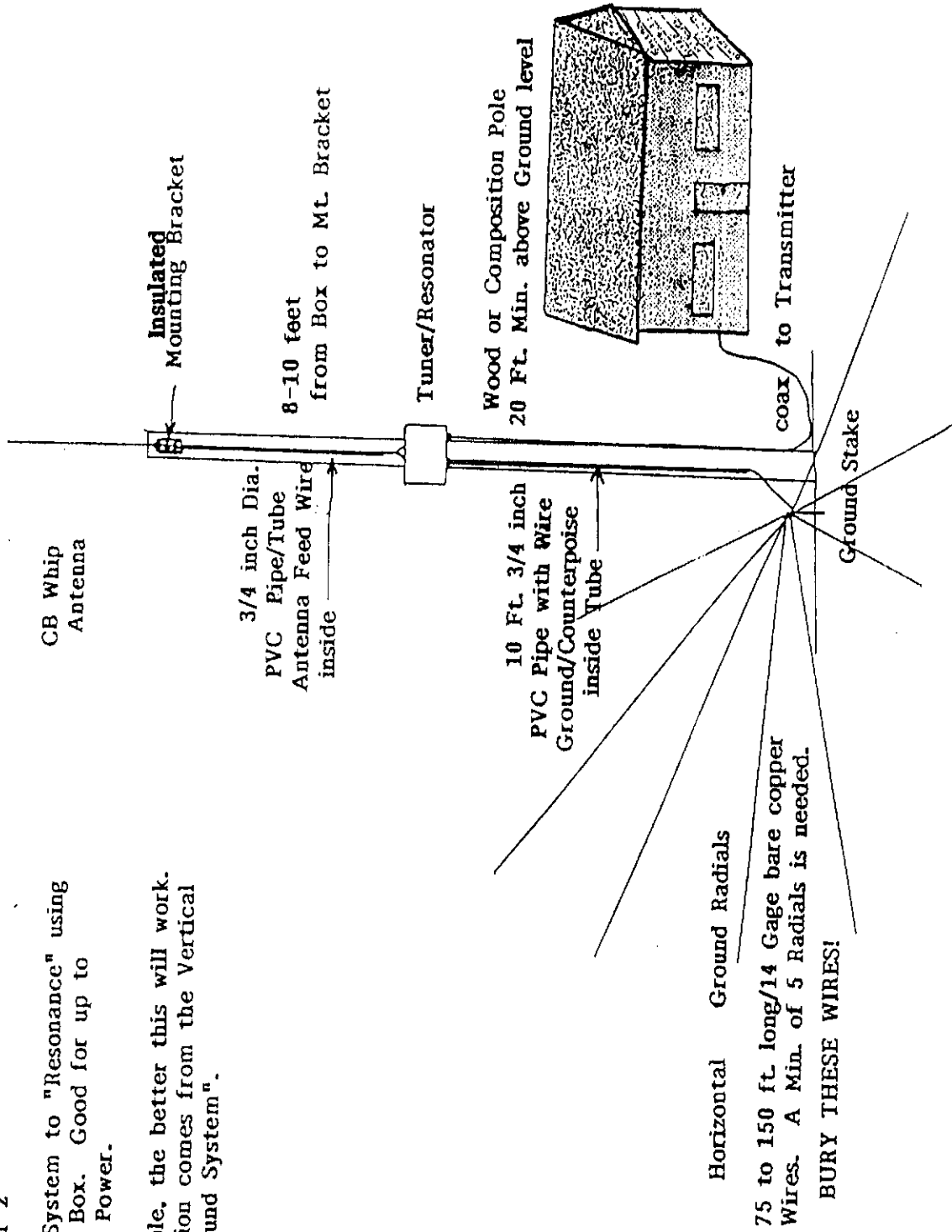

ALTERNATE METHOD  
CAMPUS A.M. BROADCAST ANTENNA

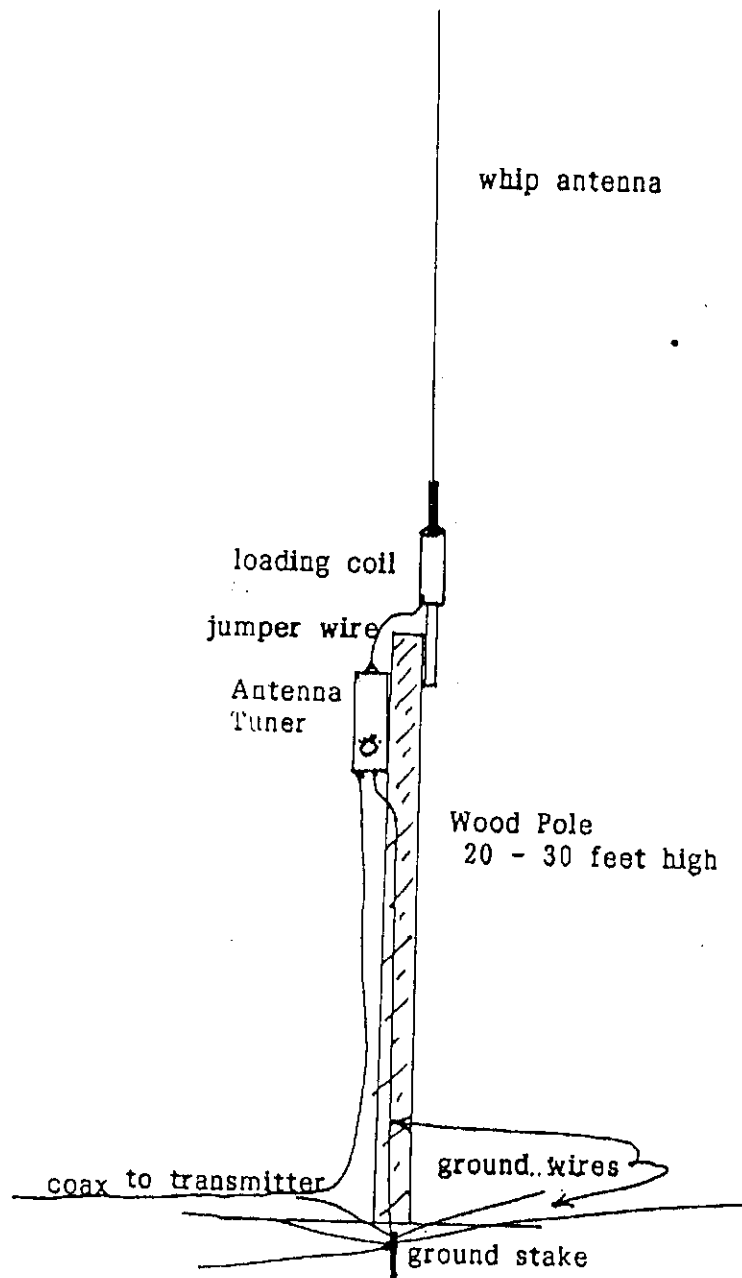

This Antenna works well for Low Power A.M. Broadcast, IF sufficient grounding is used. A minimum of 15 buried ground radials of 75 feet long is normal. Another Method is to use 4 elevated counterpoise wires on poles, with their ends terminated with ground stakes. These are connected directly to the bottom of the Tuner Box, and must be at least 5 feet above the ground level. The Counterpoise Wires must be on insulators attached to the poles to support the Counterpoise.

The Antenna Tuner must be adjusted after all Antenna Work is complete.

Missionary A.M. Whip Antenna  
With Counterpoise Ground

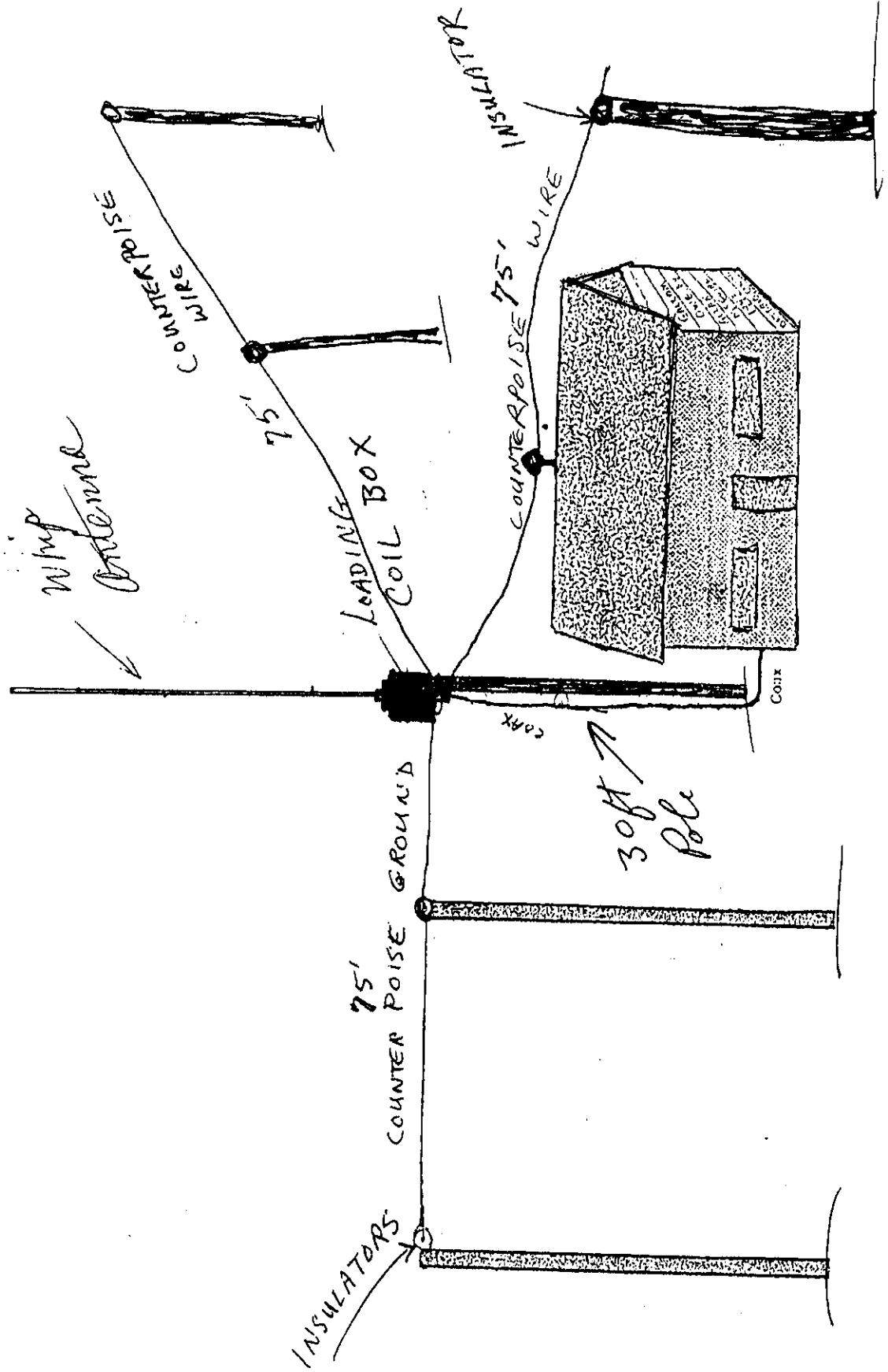

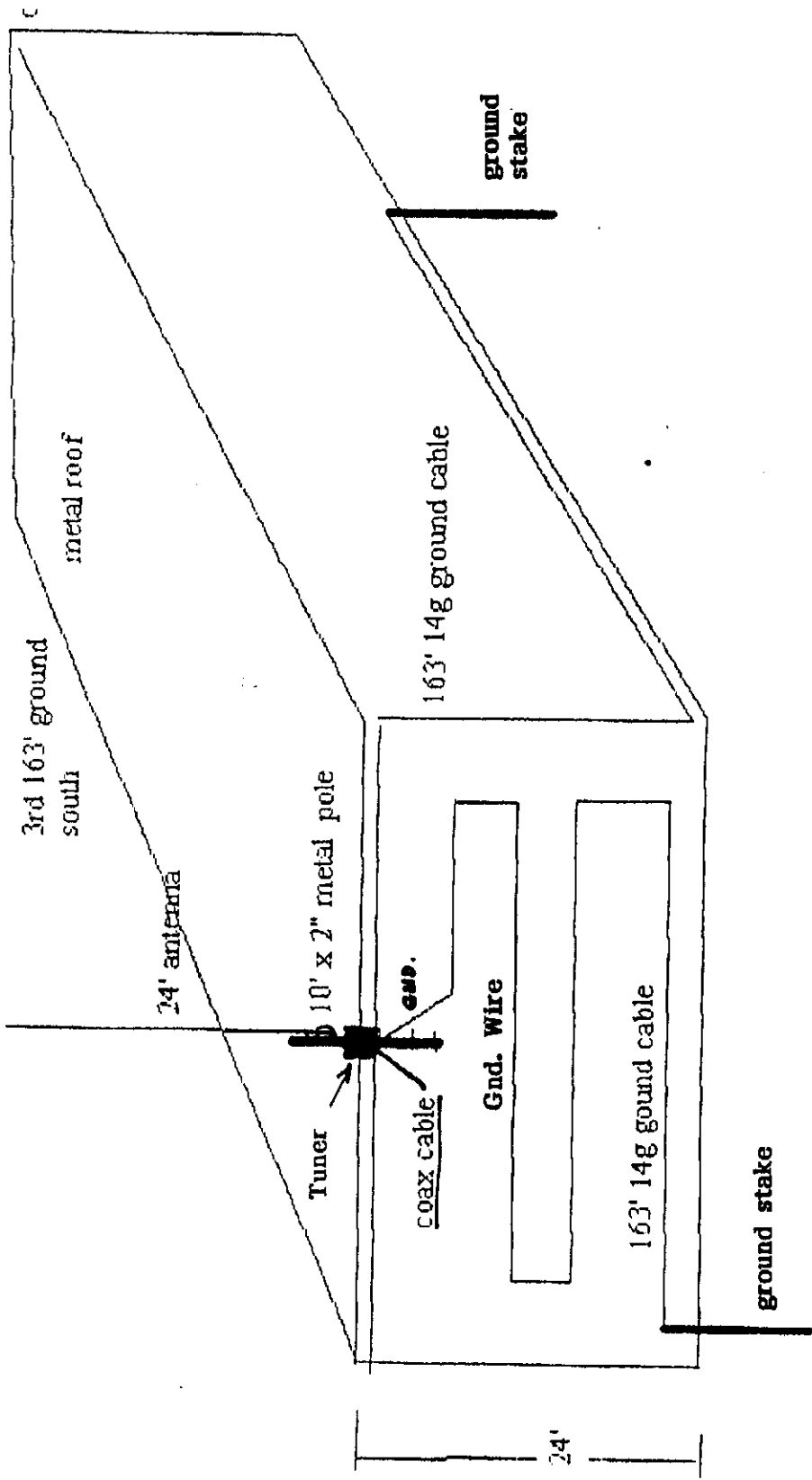

This is unique way to place a Whip Antenna on a building. The Ground Wire is held in place using short "stand off" Insulators to prevent a short.



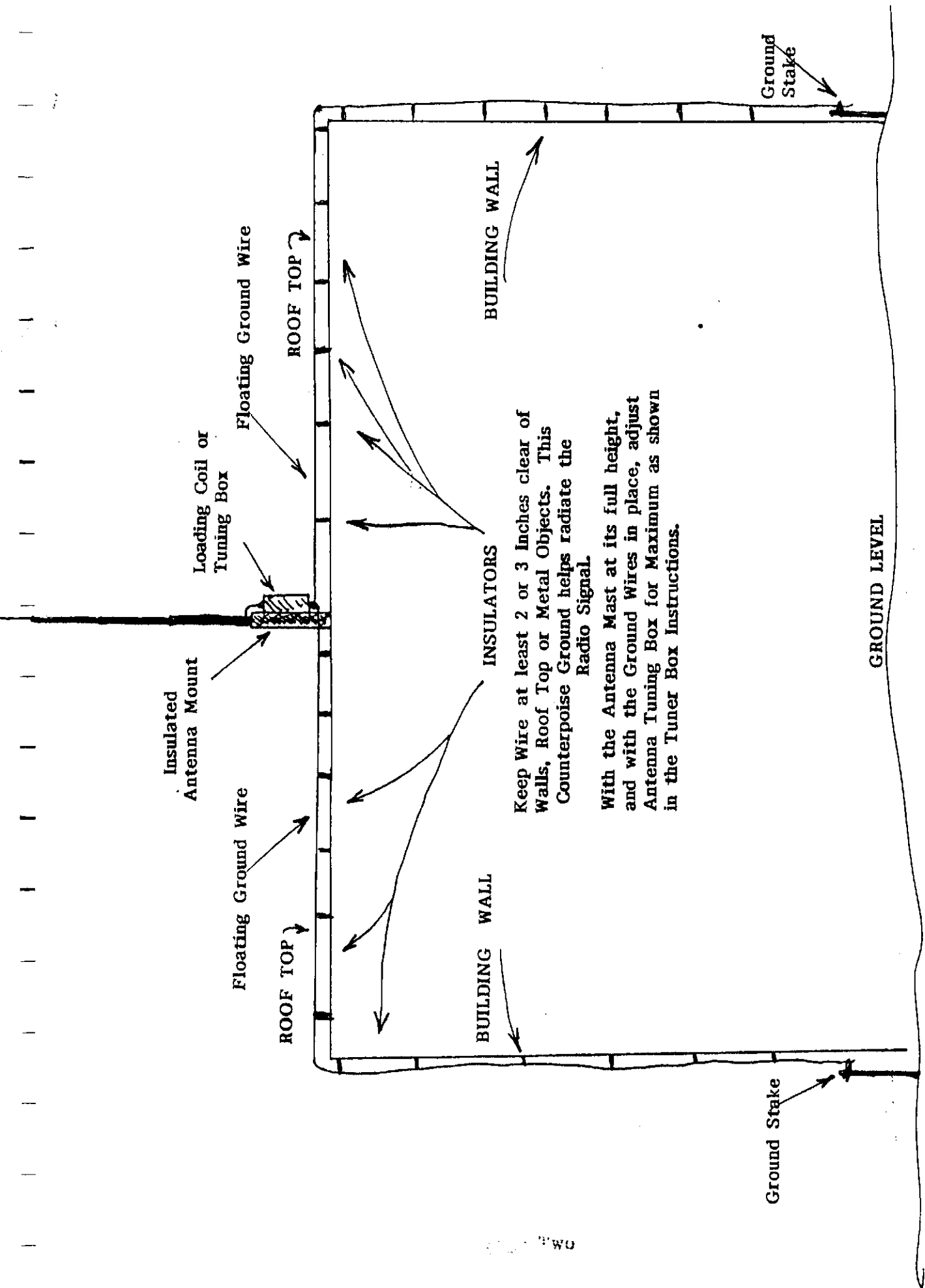

Insulated  
Antenna Mount

Loading Coil or  
Tuning Box

Floating Ground Wire

Floating Ground Wire

ROOF TOP

ROOF TOP

BUILDING WALL

INSULATORS

BUILDING WALL

Keep Wire at least 2 or 3 Inches clear of  
Walls, Roof Top or Metal Objects. This  
Counterpoise Ground helps radiate the  
Radio Signal.

With the Antenna Mast at its full height,  
and with the Ground Wires in place, adjust  
Antenna Tuning Box for Maximum as shown  
in the Tuner Box Instructions.

Ground Stake

Ground Stake

GROUND LEVEL

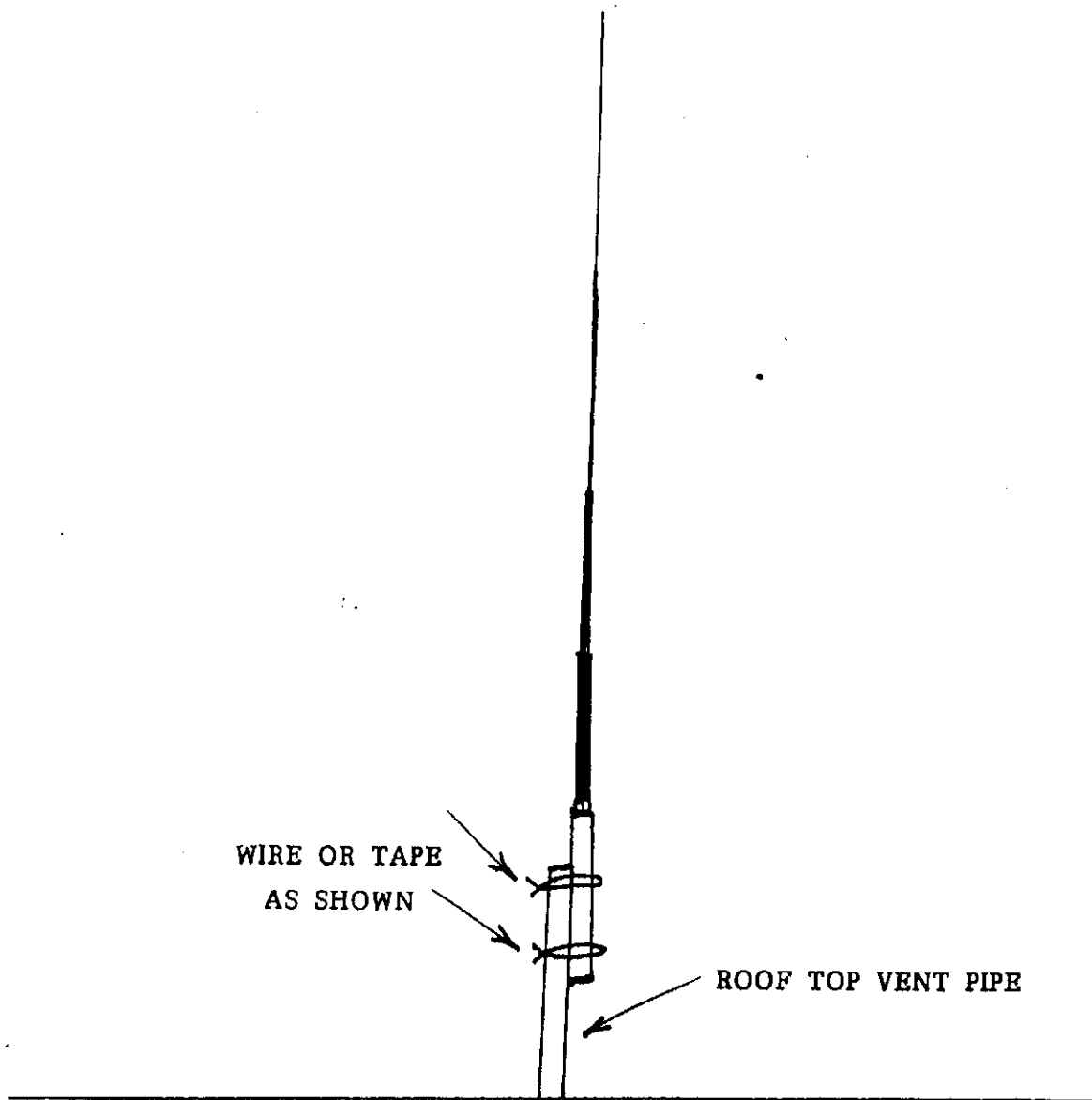

METHOD OF MOUNTING  
20-~~30~~ FT. WHIP ANTENNA

Mount the Antenna as shown, taped or wired to the vent pipe. If commercial clamps are used, BEWARE of too much pressure. The Insulative Antenna Tube may be crushed if too much clamp pressure is used.

This Antenna requires a Counterpoise Ground beneath it for proper operation. See the accompanying Information for Details.

# LOW POWER RADIO ANTENNA

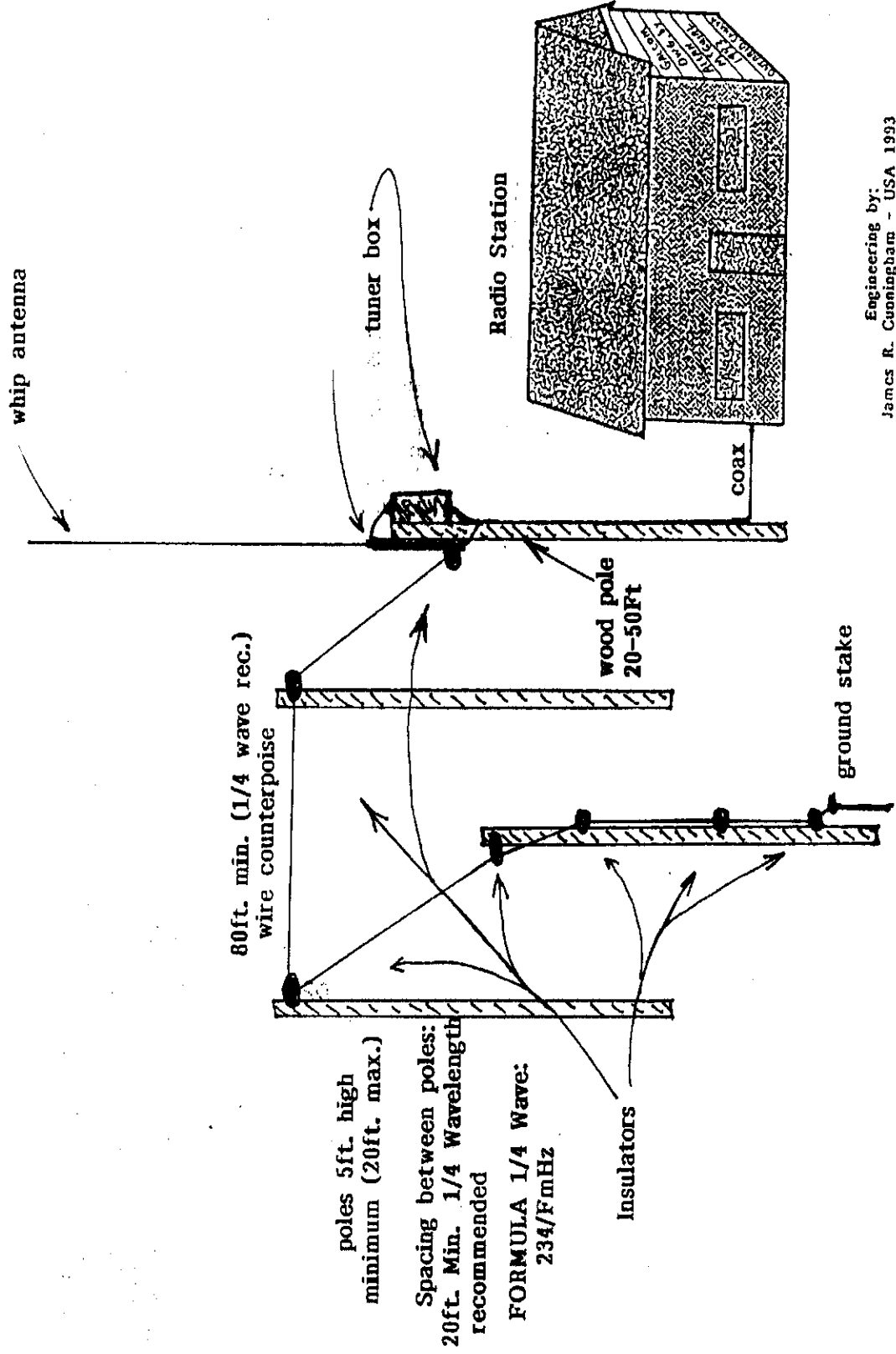

Engineering by:  
James R. Cunningham - USA 1933

# CAMPUS RADIO ANTENNA DETAILS

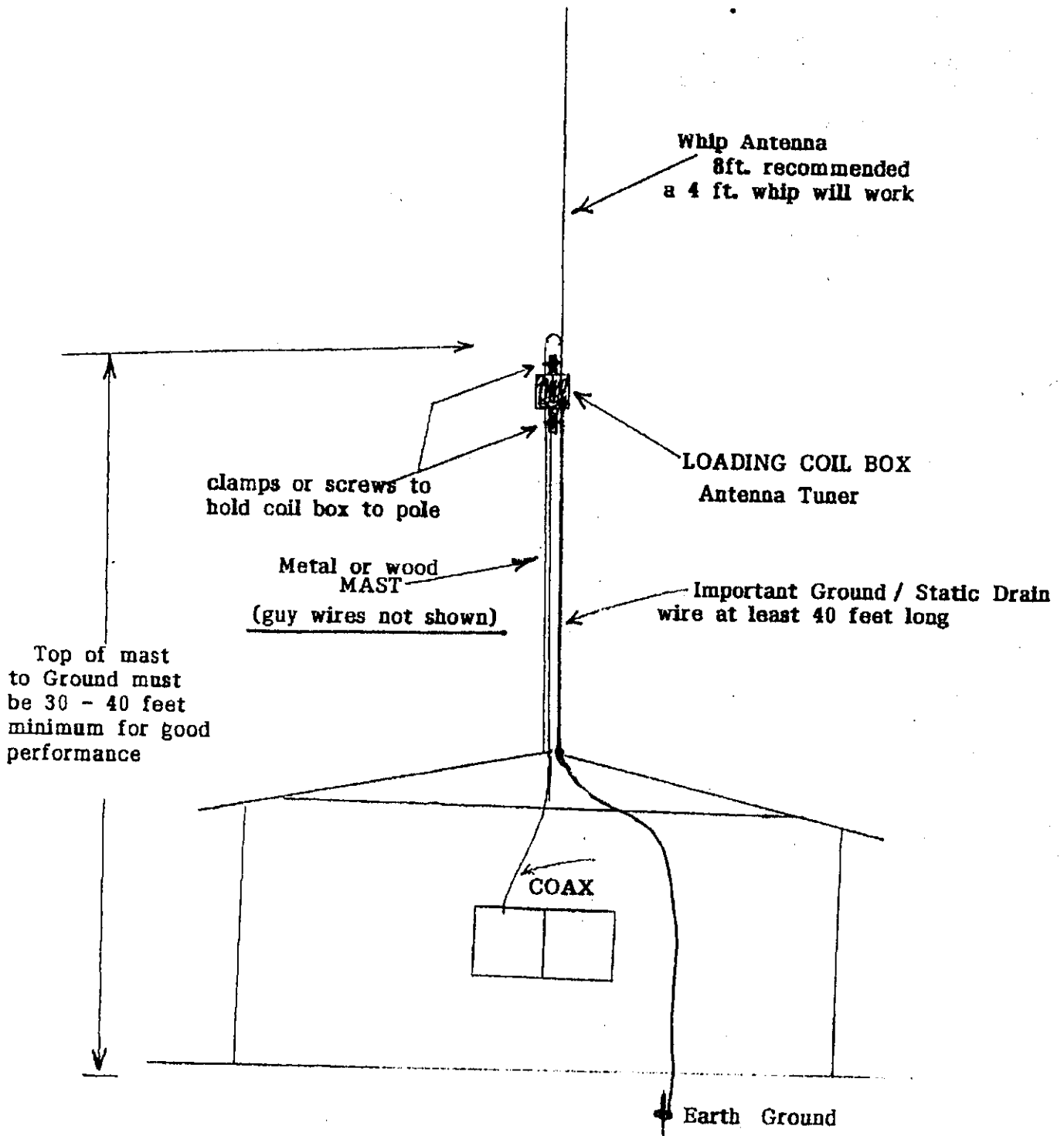

MAKE A 40-50 FOOT MAST ANTENNA  
USING 2 X 4's

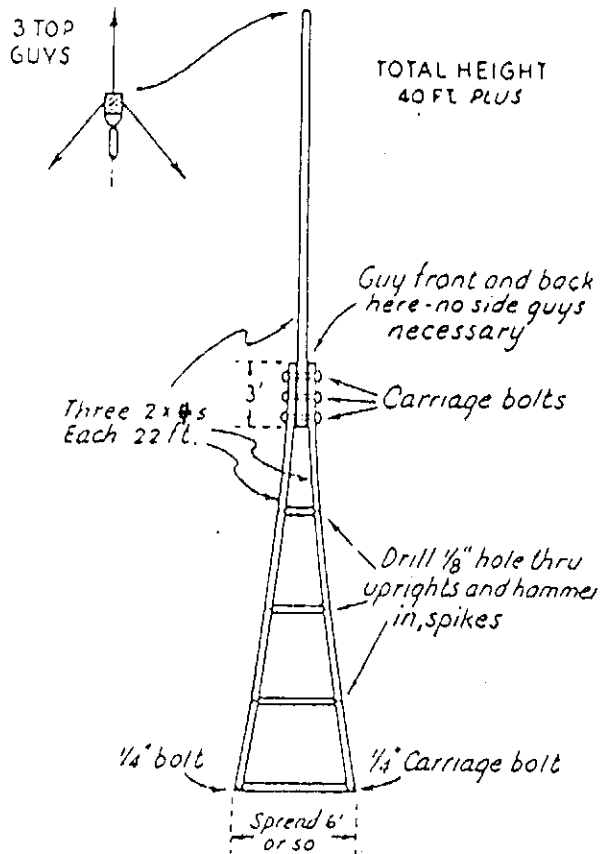

-Details of a simple 40-foot "A"-frame mast suitable for erection in locations where space is limited.

The 2X4's are put together as shown above in the drawing. You can run a vertical wire of #14 - #10 gage straight up the mast. If the wire has insulation on it, it will work for low powers of under 100 Watts. TO INCREASE POWER into the wire, either put it inside a PVC PIPE, or use STAND OFF INSULATORS. The REASON for this is that the wire is VERY HOT under full power, so it might BURN THE 2X4's and even cause a fire!

Use GUY WIRES to steady the top part of the Tower against the wind. You can mount the TUNER BOX to the bottom of the wood structure.

Use a good GROUND SYSTEM or a COUNTERPOISE. If all is well, this Tower will accept 400 Watts or more.

*Counterpoise*.—One of the most important losses due to antenna resistance is caused by dielectric losses in poor ground connections. This is especially true where stations are located on dry, sandy, or rocky land, and is due to electron displacement in dielectrics traversed by the electric field set up by the antenna. It uses up useful energy in a useless action. In other words, if this loss is reduced, more energy is left for radiation purposes.

To reduce this loss a so-called *counterpoise* is used at some stations, which consists of a network of wires, erected a few feet above the ground but insulated from it and stretched out over the ground in a radial form with the radio-transmitter house as the center.

Theoretically the counterpoise forms one plate of the condenser of which the antenna is the other plate. The entire system of antenna, counterpoise, and ground may also be considered as two condensers in series, the antenna and moist ground far below the surface forming the outside plates while the counterpoise forms the center plate of the two condensers.

Where a counterpoise is erected, the same care should be taken to insulate it as is taken with the antenna. Supports should be as few as possible, and wooden stakes should be kept out of the field formed between the counterpoise and the antenna, as wood has a high dielectric power loss. All connections in the counterpoise should be soldered as in the antenna.

Intentional Radiator  
For 1600KHZ to 30 MHZ. S.W.

40ft mast [OMNIDIRECTIONAL]

The insulated Guy Wires  
increase the overall length  
of the antenna system and  
provide better coverage.

guy wires attach to metal mast

NOTICE:  
This antenna works best for  
Frequencies above 1600 KHZ!

HOT WIRE ON TOP OF TUNER  
CONNECTS TO METAL POLE AT  
THE BASE OF THE MAST

Guy's are insulated  
at bottoms

insulators

insulator

insulator

PVC PIPE INSULATOR  
(prevent mast from  
shorting to roof)

tuner box

GROUND WIRE

GROUND STAKE

GROUND WIRES UNDER SOIL OR ON TOP  
USE AT LEAST 30 (1/4 wavelength) RADIALS

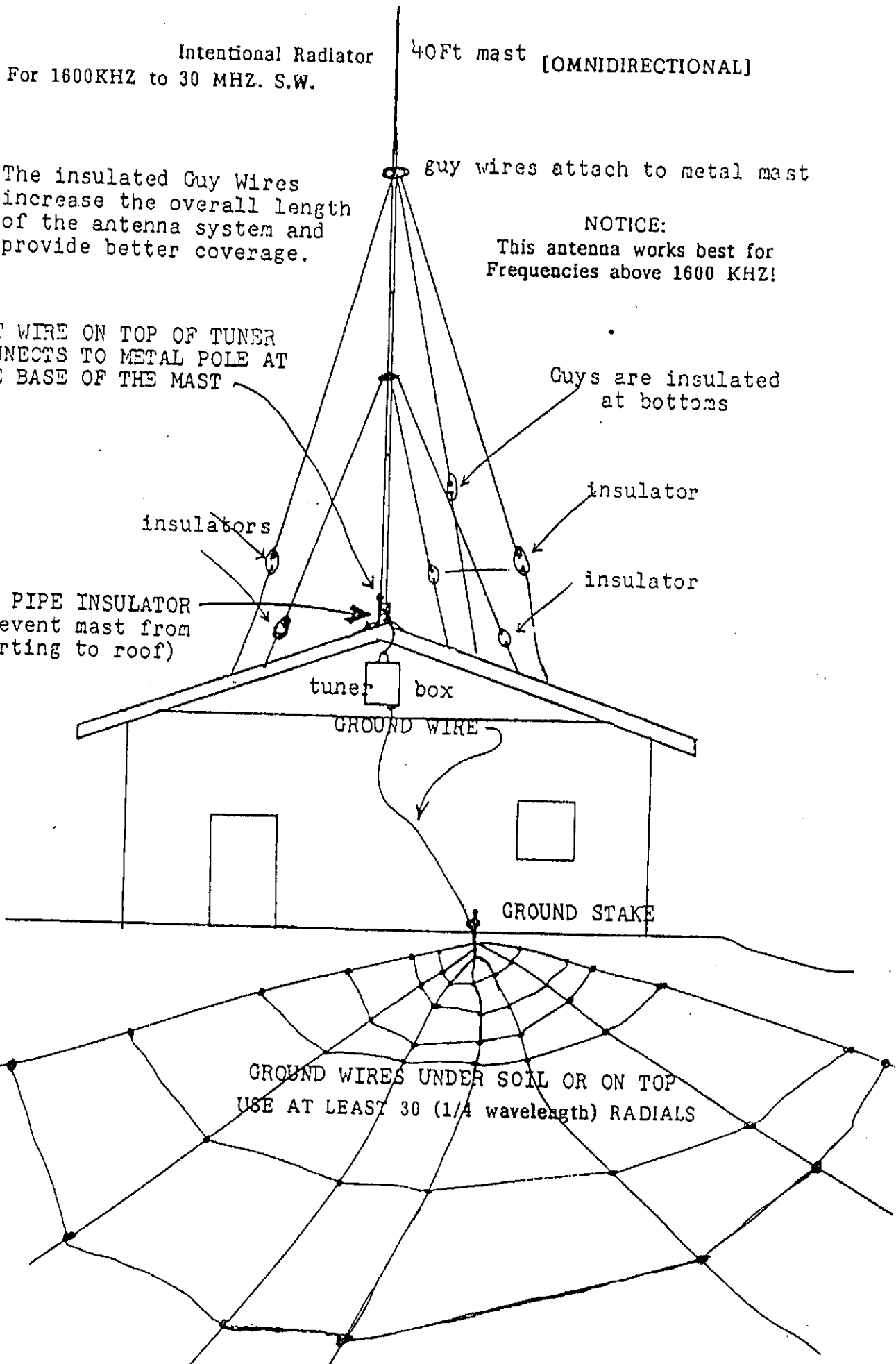

100 Watt Vertical Mast  
and Roof Top Ground Plane.

Antenna will handle 100 Watts  
if a Ground Plane is placed under  
the Mast.

36 ft antenna mast

R.S. # 15-50-67

Metal Guy Wires  
connect to Metal Mast

Insulators

Ground  
Wires

Antenna Tuner

Ground Wires

Plastic Pipe  
Insulator

coax

Transmitter  
inside

(c) Copyright  
1989 James  
Cunningham

Ground  
Stake

Ground  
Stake

The 36 Foot Antenna Mast is set up on the roof top. Under it is a Plastic Pipe Insulator to prevent the Mast from touching the roof top. A good GROUND PLANE is needed under this antenna on the roof top. Connect it to Ground Stakes.



# TOOLS, MASTS & HARDWARE REQUIREMENTS

## Tools

The majority of the tools and equipment you will need for most installations are apparent. The following is a list of useful tools and miscellaneous materials that might also come in handy.

1. A complete set of nut drivers (spin-tights).
2. A set of ratchets and sockets.
3. A pocket compass, for orienting the antenna and setting up the rotor when the compass bearing(s) of the transmitter tower(s) is known.
4. A drill brace with a wide assortment of bits.
5. A good quality leather tool belt.
6. A crimping tool for fastening coaxial connectors.
7. Caulking compound for sealing the holes where transmission line enters the house.
8. Roofing tar (plastic roof cement), for sealing around screws on the roof.
9. Silicone grease for waterproofing coaxial cable connectors.
10. A sledge hammer for driving in ground rods.
11. A level or plumb bob for ensuring that the antenna mast is installed perpendicularly.
12. A map to aid antenna orientation. (Aircraft maps are ideal. Most airports sell them.)
13. A strong step ladder (in addition to extension ladders).
14. A magnetic stud finder.
15. A small, portable TV that operates on both standard house current (117 volts AC) and batteries.

## Masts

Most antenna hardware catalogs list a wide variety of mounts and masts. Most however, are variations of a few basic types. By taking into account signal strength and ease of installation, it's not difficult deciding which site, mount, and hardware to use.

A mast (Figure 4-1) is used in every installation. The mast is the vertical tubing that supports the antenna. Conventional masts are available in 5 and 10 foot lengths. Telescoping mast units (Figure 4-2) are available in 20, 30, 40 and 50 foot lengths. Each type is available in various wall thicknesses that provide different degrees of strength and rigidity. Your choice will depend on the height, weight, and size of the antenna being installed and also on wind conditions in the area.

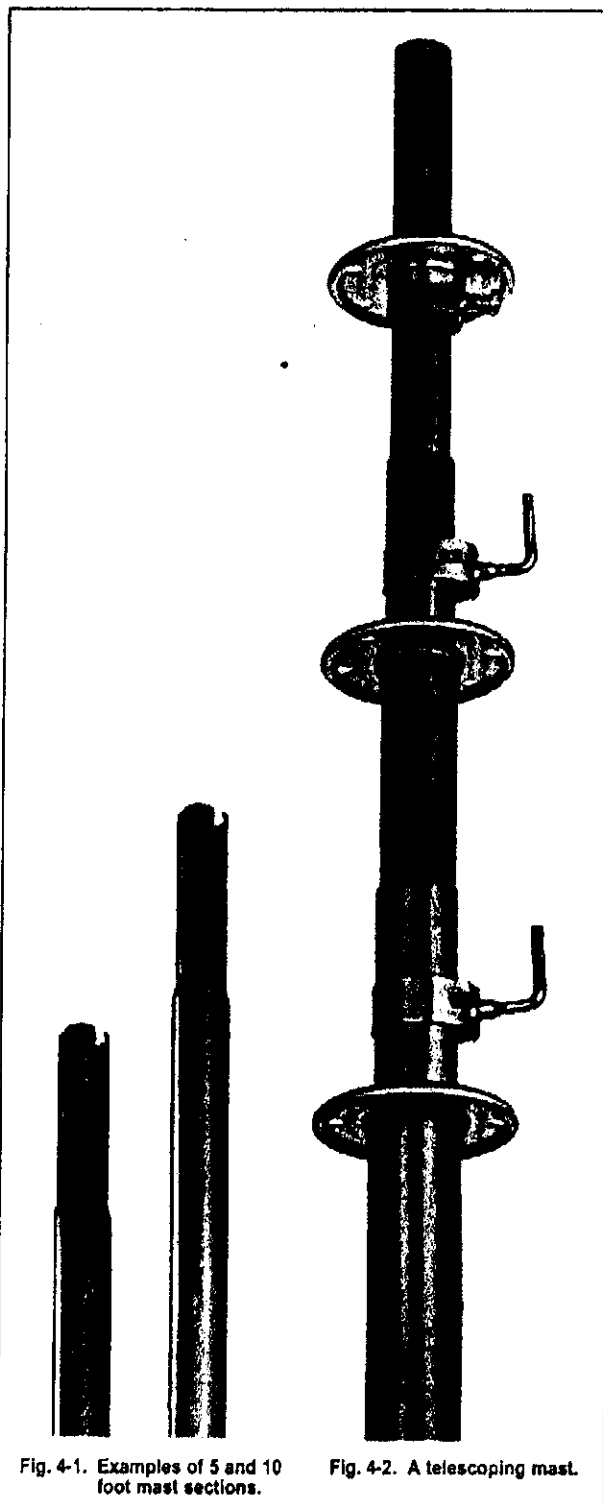
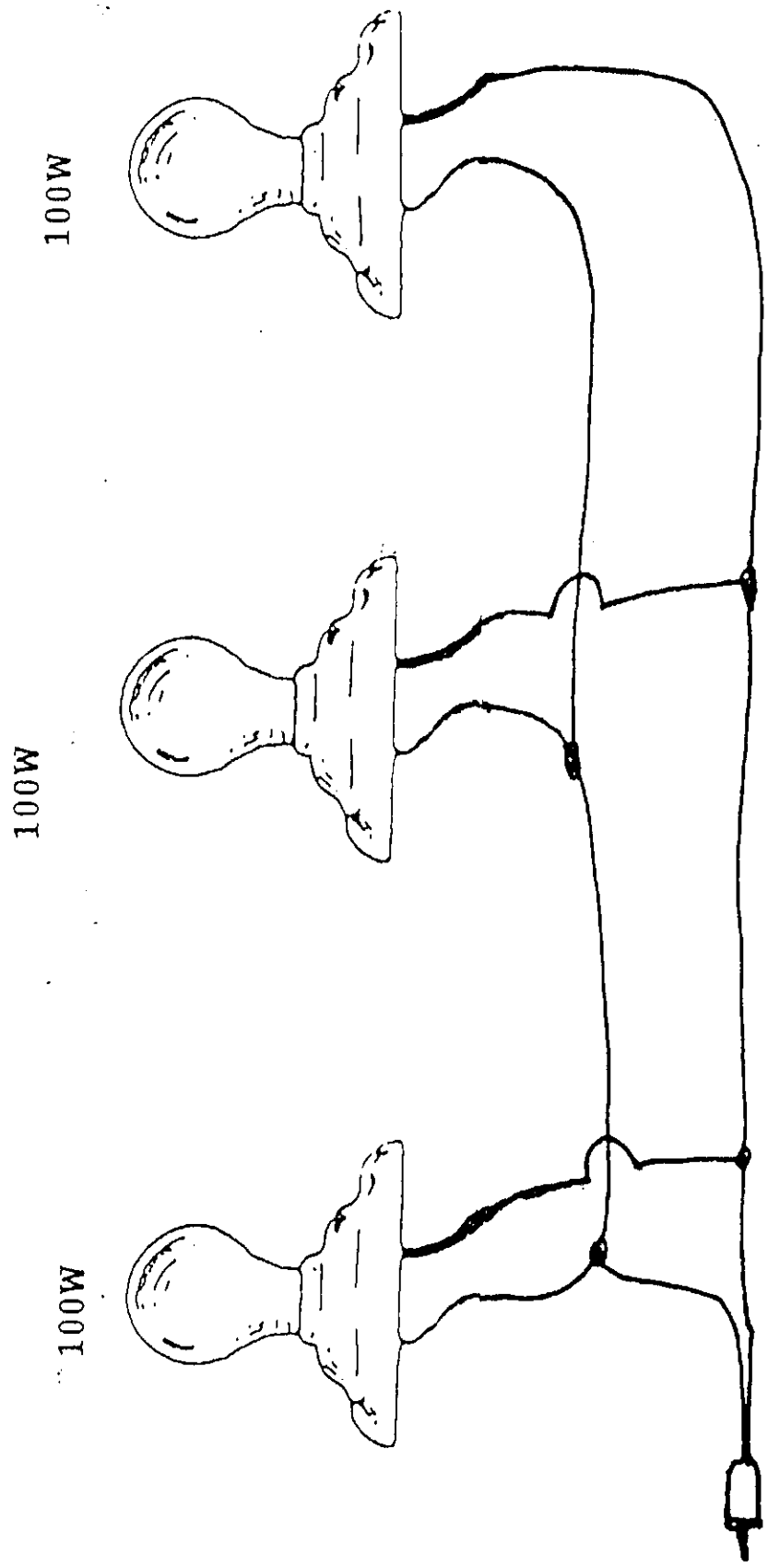

Fig. 4-1. Examples of 5 and 10 foot mast sections.

Fig. 4-2. A telescoping mast.

Both conventional and telescoping masts are available in galvanized steel and in high-tensile, acrylic-coated steel. Acrylic-coated masts are preferable because of their greater strength and durability.

POOR MAN'S DUMMY LOAD



PL 259

TOTAL RESISTANCE 48 Ohms  
perfect for AM Radio up to 300 Watts Power!

The Dummy Load is needed for checking the Transmitter and the Coaxial Cable under full Power!



20 Foot "Whip Antenna" for A.M. Radio Broadcasting. (LEFT) On Right Side, please notice that the entire Antenna Telescopes inwardly, into a 4 foot insulated Fiberglass or PVC Tube.

This System is for Roof Tops, especially higher than 30 Ft. Two "Counterpoise" Ground Wires are required as shown below. Reduced efficiency is noted at lower elevations, but performance may be acceptable above 15 Feet.

FREQUENCIES: 530 TO 1710 KHZ

Safe operation requires a minimum of 30Ft. between Antenna wires and Transmitter.

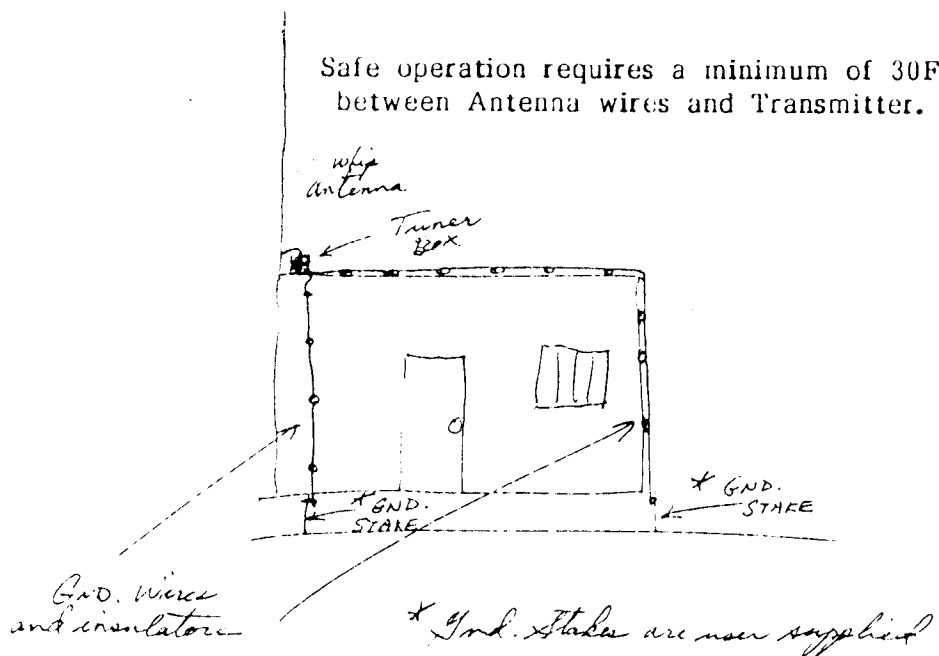

## ANTENNAS

### Wave Propagation

You know that the function of an antenna is to radiate electromagnetic energy into space. Once this energy is released from the antenna, it travels through space until it is picked up by a receiving antenna or is reflected off an object, as is the case with radar transmission.

It is important to know what happens to a radiated wave in space (namely, what its path is, if it is absorbed by the earth, if it is reflected by the sky, etc.) in order to tell how far the wave will travel before it can be picked up. The study of what happens to a radiated electromagnetic wave once it leaves the antenna is called "wave propagation."

When a radiated wave leaves the antenna, part of the energy travels through the earth following the curvature of the earth and is called the "ground wave." The rest of the energy is radiated in all directions into space. Those waves which strike the ground between the transmitter and the horizon are called "space waves." Waves which leave the antenna at an angle greater than that between the antenna and the horizon are "sky waves."

### COMPONENTS OF A RADIATED WAVE

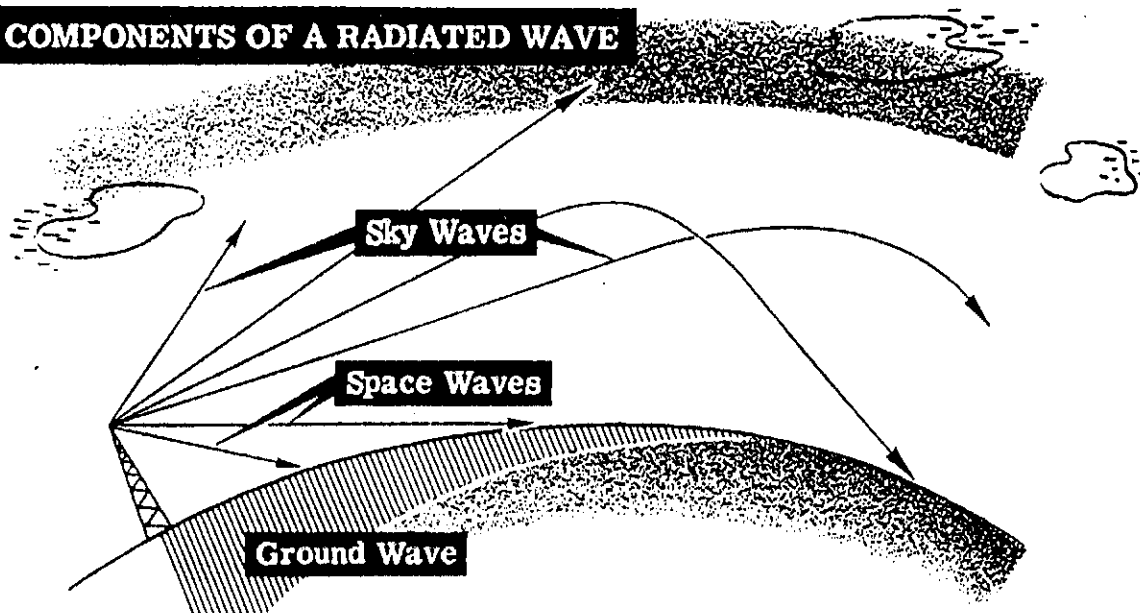

The ground wave, the space waves and the sky waves contain the transmitted intelligence. However, at certain frequencies one of the waves will be much more effective in transmitting the intelligence than the others. At comparatively low transmitted frequencies, most of the radiated energy is in the ground wave. Since the earth is a poor conductor, the ground wave is rapidly attenuated and therefore is not effective for transmission over great distances unless large amounts of transmitted power are used. The standard broadcast frequencies are examples of transmissions using ground waves. At these frequencies the effective radiating area is within 100 miles of the transmitter. As a result, neighboring cities more than 100 miles away from each other can transmit on the same frequencies and yet not interfere with each other.

## ANTENNAS AND WAVE PROPAGATION

### Wave Propagation

The function of the transmitter antenna is to radiate the transmitter signal into space. The radiated signal is electromagnetic energy, and it travels through space in a manner that is determined by its frequency. When a radiated wave leaves the antenna, part of the energy travels through the surface of the earth and is known as the "ground wave". The remainder of the energy is radiated into space in a pattern that is determined by the antenna design. Those waves which strike the ground between the transmitter and the horizon are known as the "space waves". Those waves which travel at an angle sufficiently high to pass over the horizon are known as "sky waves". At certain frequencies the upper layers of the atmosphere reflect and refract a portion of the sky wave back towards earth so that extremely long range reception is possible. At different frequencies some of these waves are more effective than others in transmitting signals.

At the frequencies used for FM transmission and television the ground waves are rapidly attenuated. In addition, the sky waves are not reflected or refracted back towards the ground so that they can be picked up by the receiver antenna. Because of this, reception is limited to the region within which the space waves can travel in a direct line of sight from the transmitting antenna to the receiving antenna. Thus reception is limited by the curvature of the earth. This range can be extended slightly when the transmitter is sufficiently powerful to cause some appreciable amount of sky wave to be bent back towards earth.

If both the transmitting and receiving antennas are at altitudes of 100 feet above sea level, FM transmission can take place at ranges in the order of 30 miles. If both antennas are raised to 1000 feet above sea level, FM reception can take place at ranges in the order of 80 miles. In mountain areas antenna elevations may be sufficiently high to permit reception at ranges over 150 miles. In cases where hills and buildings obstruct the line of sight this situation may cause severe decrease in the quality and range of reception.

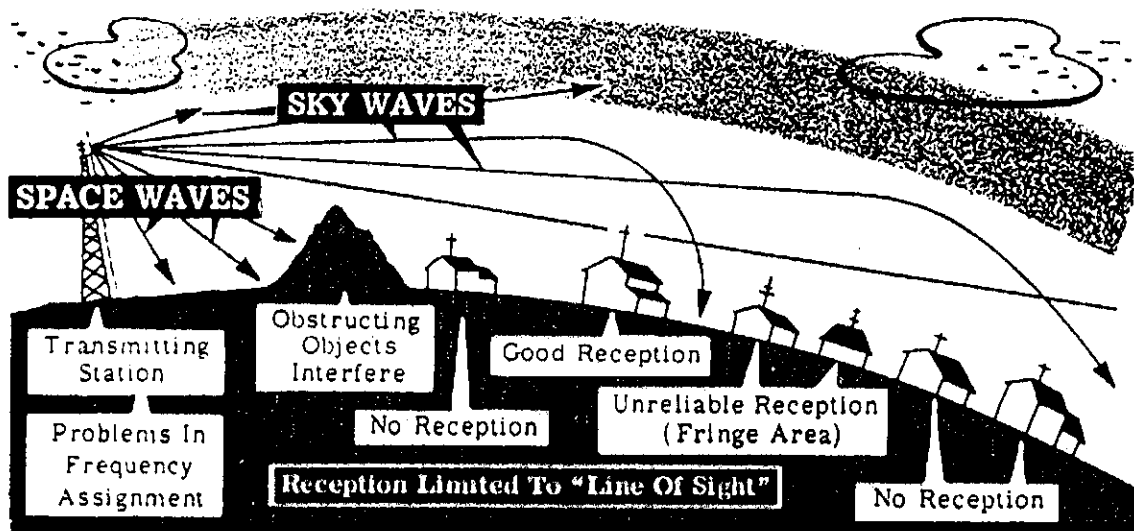

## AM RADIO

In order for AM Radio Transmissions to be effective, the Antenna must be located in a place where there is good GROUND CONDUCTIVITY.

### WHAT IS GROUND CONDUCTIVITY?

GROUND CONDUCTIVITY is dependent upon how much water is directly below the soil or on top of the soil. THIS WATER ACTUALLY BECOMES THE BOTTOM HALF OF YOUR ANTENNA SYSTEM, AND IS RESPONSIBLE FOR CARRYING THE SIGNAL TO YOUR LISTENERS. Without PLENTY OF WATER OR GOOD GROUND CONDUCTIVITY, THE AM SIGNAL WILL NOT REACH YOUR LISTENERS!

### THE GROUND WAVE

The GROUND WAVE is what good AM RADIO RECEPTION DEPENDS ON! The Sky Wave is needed for SHORT WAVE (above 3 MHZ to about 30 MHZ) but can not be depended upon for good AM Reception, because of FADING and SKIP.

A GOOD GROUND WAVE will be present where there is GOOD GROUND CONDUCTIVITY! Where GROUND CONDUCTIVITY IS EXCELLENT, A 50 WATT AM SIGNAL OFTEN REACHES OUT 50 MILES OR BETTER!

Where POOR GROUND CONDUCTIVITY IS PRESENT, THE SAME 50 WATT SIGNAL WILL CARRY ONLY ABOUT 3 MILES FROM THE ANTENNA!

### BIG TOWER - LITTLE TOWER

Where there is poor GROUND CONDUCTIVITY, a really BIG TOWER will not provide a good signal, but where there is GOOD GROUND CONDUCTIVITY, even a simple sky loop WIRE ANTENNA will provide a tremendous coverage area!

### DO NOT PUT YOUR AM TOWER HERE!

NEVER put the AM Tower on a hill top! That is the very WORSE PLACE IT CAN BE, BECAUSE IT IS THE FARTHEST AWAY FROM THE WATER TABLE! AM TOWERS BELONG IN THE VALLEY FOR BEST OPERATION!

## POOR GROUND CONDUCTIVITY?

Where there is an existing AM Tower placed on a hill, or where there is no other piece of land available for a Tower Site, there is a way to achieve basic coverage with your AM Signal.

The FIRST THING NECESSARY IS TO DO SOMETHING TO IMPROVE THE GROUND WAVE! The single MOST IMPORTANT THING IS TO PUT A LOT OF LONG COPPER WIRES OR STRAPS going out from the Tower in all directions! They must be at least 1/4 wave length, or they will simply be a waste of money! At AM Frequencies, 5 - 10 Meter Radials are a waste of both money and time, UNLESS YOU HAVE EXCELLENT GROUND CONDUCTIVITY IN THE FIRST PLACE. IN SUCH CASES, THE WATER BENEATH THE SURFACE OF THE EARTH SERVES AS THE GROUND SYSTEM.

Where GROUND CONDUCTIVITY IS POOR, A MINIMUM OF 50 Radials is needed; but 120 Radials of 1/4 Wave Length is the International Standard! With this amount of wire about the Tower (or wire antenna's base) you will be able to set up a ground wave that is acceptable for most areas, even if there is not much underground water!

For Power Levels below 1000 watts, #14 gage through #10 gage wires are the best choice, but at HIGH AM POWER LEVELS, 30 COPPER (or Aluminum) STRAPS of 1/4 Wavelength (about 4-6 inches wide) will dramatically IMPROVE your Signal!

AFTER you have placed A MINIMUM OF 50 GROUND RADIALS OF 1/4 WAVELENGTH OR BETTER, just below the surface of the earth, you may now wish to improve the coverage even more by going from a short 1/4 Wavelength Tower to a TALL 1/2 or .6 Wavelength Tower! The added HEIGHT adds to the strength of THE GROUND WAVE! The Tower itself can not radiate a desirable signal without the improved GROUND SYSTEM! Millions of dollars of WASTED MONEY have been spent on HIGHER AND LARGER TOWERS, with almost NO IMPROVEMENT IN THE AREA OF SIGNAL COVERAGE, because WITHOUT A GOOD GROUND SYSTEM, AM RADIO IS IMPOSSIBLE!!

# HEAVISIDE LAYER

Transmitter  
Antenna

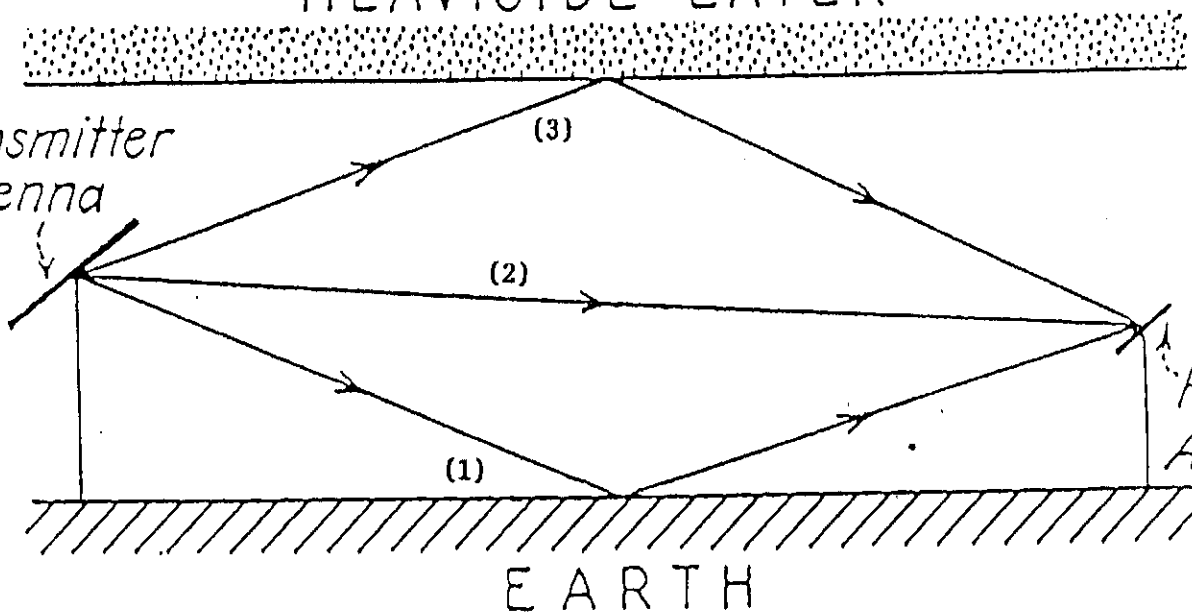

Receiver  
Antenna

EARTH

(a) - Propagation Paths of Radio Waves in AM Broadcast Band

Note: A.M. Broadcasts travel out through (1) GROUND WAVE, (2) SPACE WAVE and (3) SKY WAVE

# HEAVISIDE LAYER

Transmitter  
Antenna

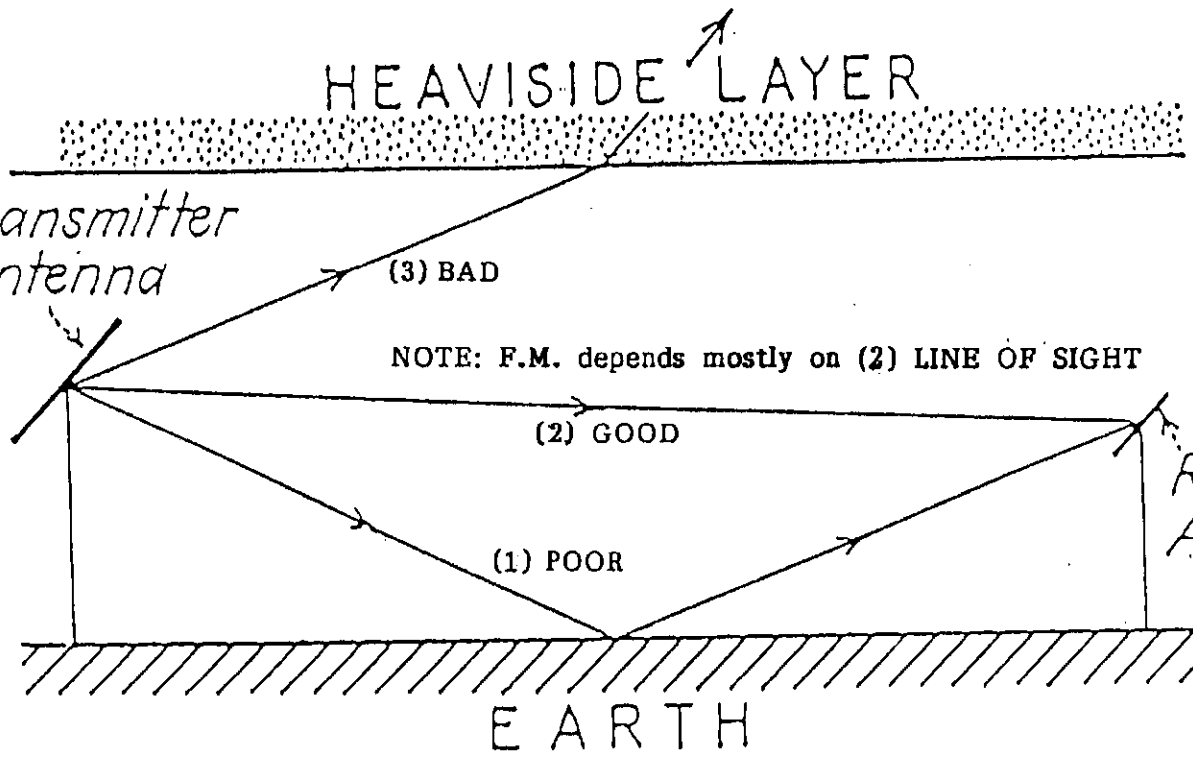

Receiver  
Antenna

EARTH

(b) - Propagation Paths of Radio Waves in FM Broadcast Band



## ~~A~~ TRANSMITTING FREQUENCIES...

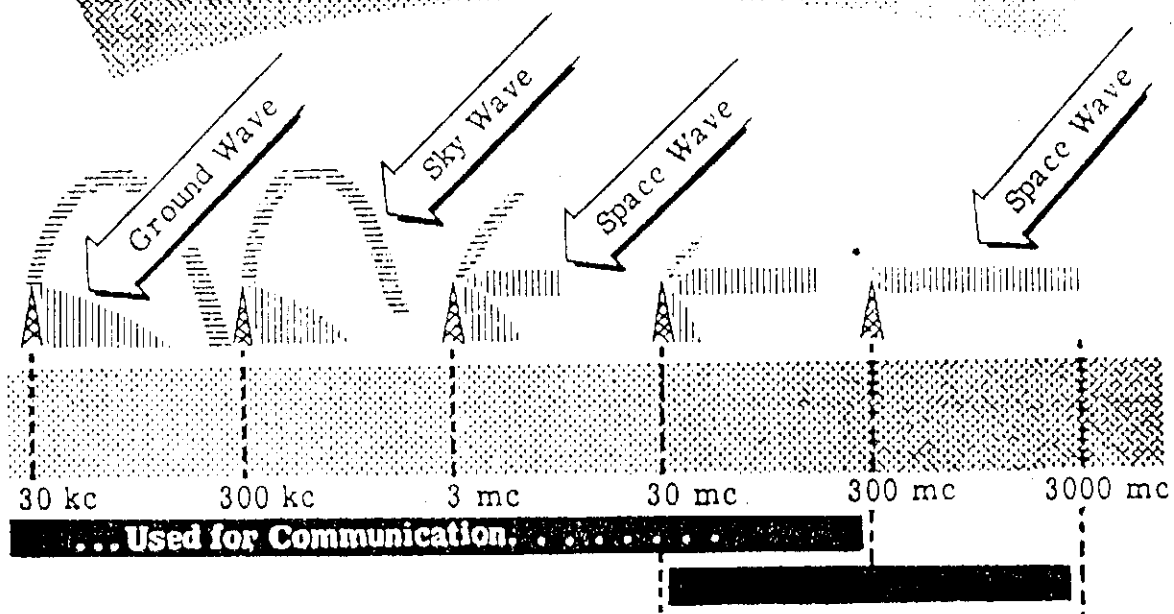

### Frequency Spectrum

The following is an outline of the components of a radiated wave which are used for transmission at various frequencies:

From 30 to 300 kilocycles (low frequency band) the ground wave is largely used for medium range communication since its stability is not affected by seasonal and weather changes. For very long distance communication, the sky wave is used.

From 300 to 3000 kilocycles (medium frequency band), the range of the ground wave varies from 15 to 400 miles. Sky wave transmission is excellent at night for ranges up to 8000 miles. In the daytime, however, sky wave transmission becomes erratic, especially at the high end of the band.

From 3 to 30 megacycles (high frequency band), the range of the ground wave decreases rapidly and sky wave transmission is highly erratic depending upon the seasonal factors previously mentioned. Space wave transmission begins to become important.

From 30 to 300 megacycles (very high frequency band VHF), neither the ground wave nor the sky wave are usable, and space wave transmission finds major application.

From 300 to 3000 megacycles (ultra-high frequency band UHF), space wave transmission is used exclusively.

# Reactance Chart

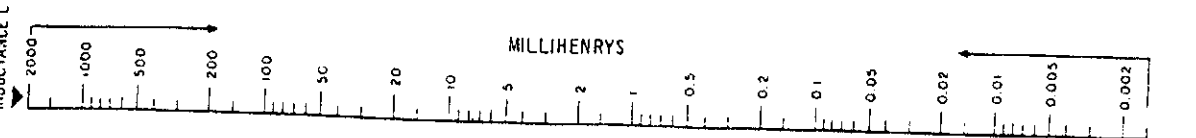
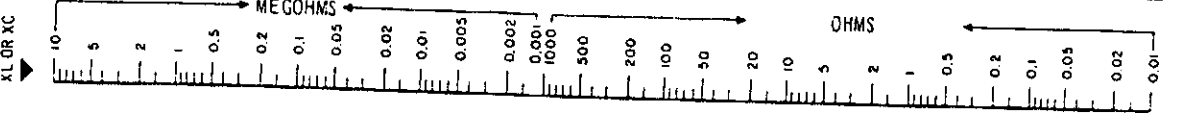
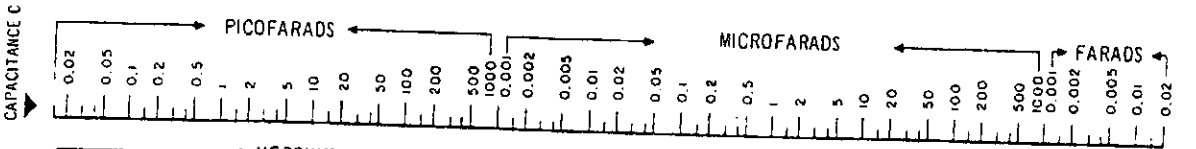
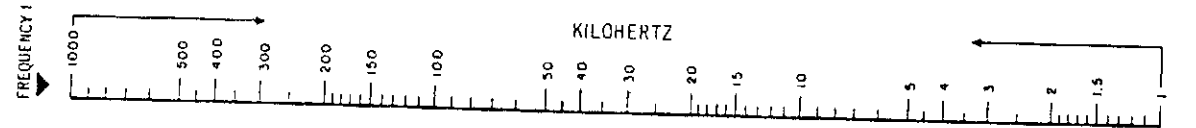
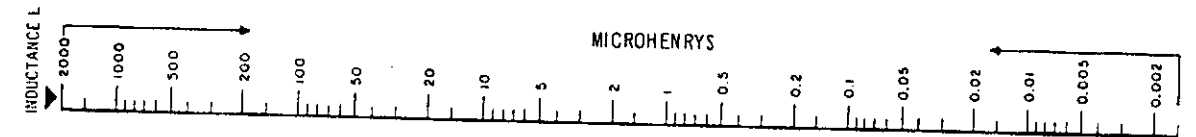
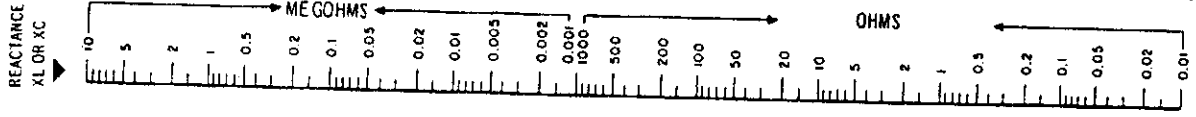
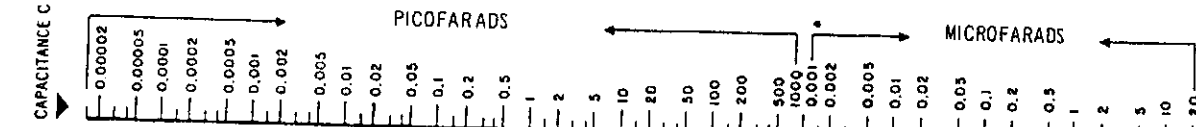
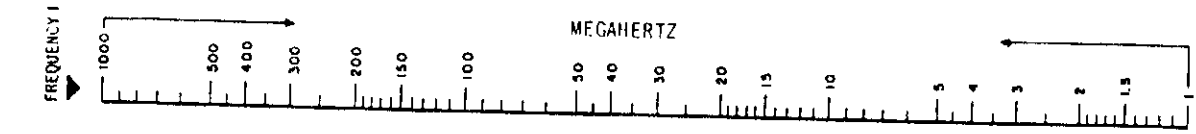

Lay a straight edge across the values which are known, to discover the "unknown" answers

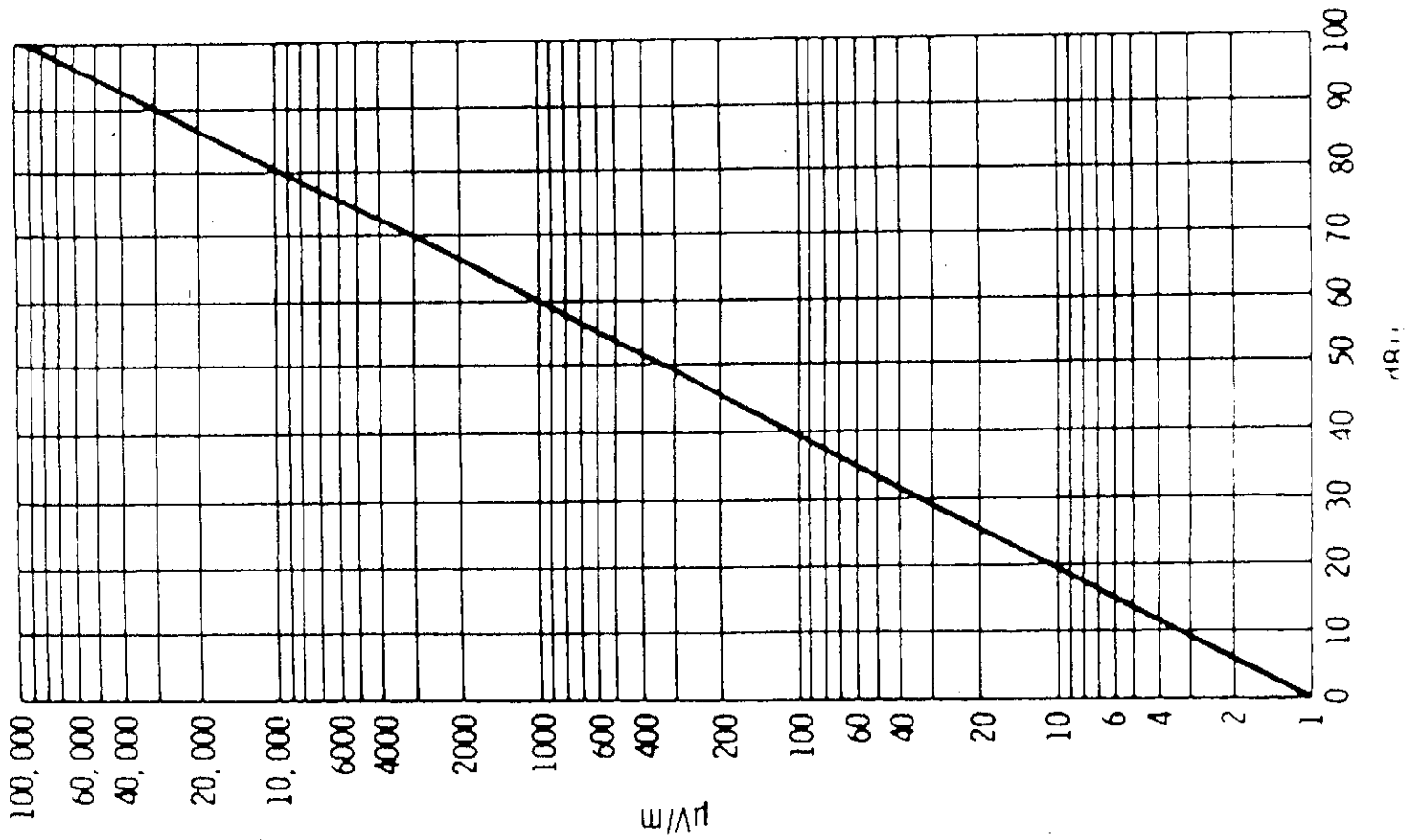

**Fig. 2-17. Graph relating dBu to microvolts per meter.**

IDEALIZED REACTANCE VALUES  
Over "Perfect" Ground Plane

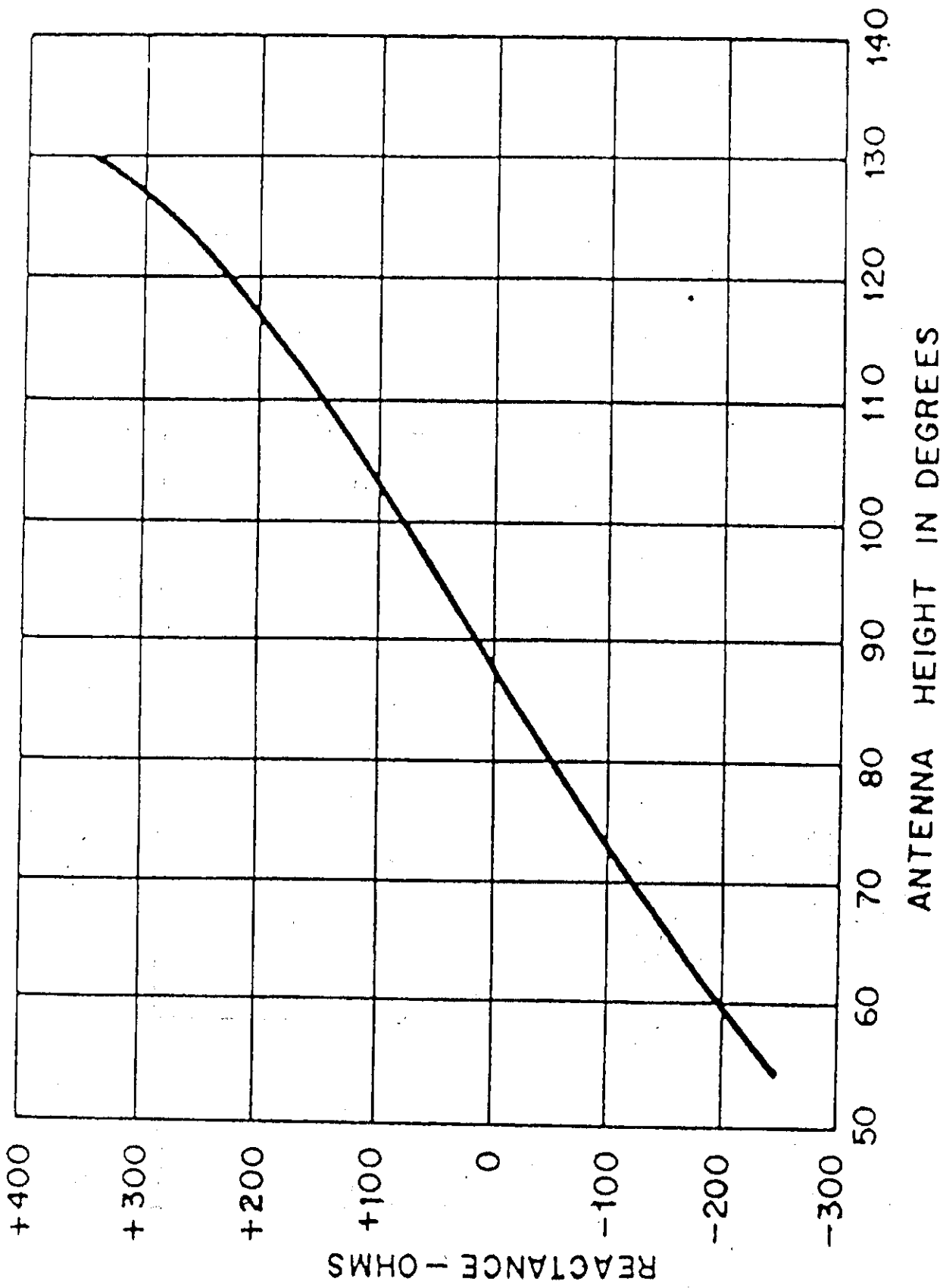

Courtesy J.R. Cunningham

Typical antenna resistance and reactance values. (Source: Ennes: AM-FM Broadcasting)				
Antenna Height (Electrical Degrees)	Self-Supporting Towers		wires Guyed Towers	
	Resistance (Ohms)	Reactance (Ohms)	Resistance (Ohms)	Reactance (Ohms)
50	7	-j100	8	-j222
60	9	-j70	13	-j170
70	14	-j25	19	-j175
80	20	+j11	28	-j28
90	40	+j35	36	+j0
100	60	+j80	80	+j140
110	90	+j90	140	+j320
120	175	+j80	220	+j500
130	190	+j15	370	+j600
140	165	-j70	660	+j480
150	130	-j85	1100	+j0
160	82	-j55	550	-j250
170	60	-j25	280	-j450
180	40	-j5	180	-j500
190	28	+j25	120	-j430
200	23	+j50	80	-j400

**1. HOW TO FIGURE ELECTRICAL DEGREES OF AN ANTENNA:**

A. Multiply FEET X Frequency in Mega Hertz, X .0010683761 X 360.

Velocity Factor of Metal Antenna Wire or Rod is already Factored into the Formula

**2. TO FIND HOW MANY FEET PER ELECTRICAL DEGREE:**

A. DIVIDE 936 by FREQUENCY IN MHZ., THEN DIVIDE BY 360.

**ANTENNA FEEDPOINT VOLTAGES AT 50 WATTS POWER**

1/4 Wavelength (90 Degrees) - 42.7 Volts Minimum with no modulation

1/2 Wavelength (180 Degrees) - 96.1 Volts Minimum with no modulation

144 Degrees - 181 Volts with no modulation

160 Degrees - 166 Volts with no modulation

WITH MODULATION, MULTIPLY THESE VOLTAGES BY 4 (peak to peak).

ANTENNA RESISTANCE/REACTANCE  
CHART

Antenna Height* in Electrical Degrees	Self-Supporting Type		Guyed-Mast Type WIRE ANTENNA	
	R	jX	R	jX
50	7	-j100	8	-j220
60	9	-j 70	13	-j170
70	14	-j 25	19	-j 75
80	20	+j 11	28	-j 28
90	40	+j 35	36	+j 0
100	60	+j 80	80	+j140
110	90	+j 90	140	+j320
120	175	+j 80	220	+j500
130	190	+j 15	370	+j600
140	165	-j 70	660	+j480
150	130	-j 85	1100	+j 0
160	82	-j 55	550	-j250
170	60	-j 25	280	-j450
180	40	-j 5	180	-j500
190	28	+j 25	120	-j430
200	23	+j 50	80	-j400

\*Valid For A.M. Radio Frequencies over Average Conductivity Earth

Courtesy J.R. Cunningham 1994

## ANTENNA RESISTANCE

### 1. HOW TO FIGURE ELECTRICAL DEGREES OF AN ANTENNA:

A. Multiply FEET X Frequency in Mega Hertz, X .0010683761 X 360.

Velocity Factor of Metal Antenna Wire or Rod is already Factored into the Formula

### 2. TO FIND HOW MANY FEET PER ELECTRICAL DEGREE:

A. DIVIDE 936 by FREQUENCY IN MHZ., THEN DIVIDE BY 360.

## VITAL INFORMATION

### ODD ANTENNA RESISTANCE READINGS:

1. 128 Degrees - 220 Ohms with 500 Ohms Capacitive Reactance
2. 144 Degrees - 660 Ohms with 480 Ohms Inductive Reactance
3. 160 Degrees - 550 Ohms with 250 Ohms Capacitive Reactance
4. 171 Degrees - 280 Ohms with 450 Ohms Capacitive Reactance

### ANTENNA FEEDPOINT VOLTAGES AT 50 WATTS POWER

1/4 Wavelength (90 Degrees) - 42.7 Volts Minimum with no modulation

1/2 Wavelength (180 Degrees) - 96.1 Volts Minimum with no modulation

144 Degrees - 181 Volts with no modulation

160 Degrees - 166 Volts with no modulation

WITH MODULATION, MULTIPLY THESE VOLTAGES BY 4 (peak to peak).

NOTE: OTHER POINTS ALONG THE ANTENNA WILL CONTAIN EXTREMELY HIGH AND DANGEROUS VOLTAGES! BEWARE!

### LEAD IN WIRES:

INCLUDE THE LENGTH OF ANY LEAD IN WIRES IN YOUR TOTAL ANTENNA LENGTH CALCULATIONS FOR RESISTANCE, IMPEDANCE, VOLTAGE OR CURRENTS.

CURRENTS MAY BE MEASURED DIRECTLY USING AN APPROVED THERMAL COUPLED TYPE AMMETER OR OTHER F.C.C. APPROVED METHOD.

TYPICAL GAIN  
FOR  
VARIOUS ANTENNA DESIGNS

1. Rhombic - 10 to 16 db over a vertical 1/4 wavelength Tower
  - (a) "V" Antennas show similar figures
2. DISCONE -
3. Helical - 11db at 100mhz, 15db at 220 mhz.
4. Cubical Quad - 7 to 10 db (2 elements)
5. LOOP ANTENNAS - Horizontal wires become VERTICALLY POLARIZED and vice-versa.
  - (a) Horizontal - 3.4db over a vertical 1/4 wavelength tower or 2db over 1/2 wave
  - (b) Vertical Loops operate as quads and are Horizontal in polarization.
  - (c) LOOPS SHOULD BE 1 wavelength for best operation or 1/2 wave minimum.
6. Colinears - Two Elements have 1.8db gain, 3 elements show 3.3db gain, 4 elements show 4.5 db gain, 5 elements show 5.3 db gain and 6 elements show 6.2 db gain.
7. YAGIS
  - (a) 2 elements - 4.3 to 5.3 db gain
  - (b) 3 elements - .1 wave spacing = 7db gain, .2 wave spacing shows 9db gain, and .25 wave spacing shows 9 db gain.
  - (c) 4 elements - .2 wave spacing shows 10db gain.
  - (d) 5 elements - .2 wave spacing shows 11db gain.
8. End Fire Antennas - 3/4 wavelength (5db), 1 wave (6db), 2 wave (8.5db), and 3 wave (10db).
9. QUARTER WAVE VERTICAL - 1 db Gain
10. HALF WAVE VERTICAL - 1.7 db Gain
11. FOLDED DIPOLES - up to 4 db gain over a 1/4 wavelength Antenna
12. 5/8 wavelength VERTICALS - 3 db gain over a 1/4 wave vertical (5/8λ J-POLES)  
3.4db Gain

COURTESY OF:

Southeastern Technical Services  
J.R. Cunningham  
P.O. BOX 8, Stonewall, OK 74871 USA  
Telephone: (405) 265-4496



## Voltage Standing Wave Ratio Relationships

VSWR	REFLECTION COEFFICIENT	RETURN LOSS	POWER RATIO	PERCENT REFLECTED
1.01 : 1	.0050	46.1 dB	.00002	.002%
1.02 : 1	.0099	40.1 dB	.00010	.010%
1.04 : 1	.0196	34.2 dB	.00038	.038%
1.06 : 1	.0291	30.7 dB	.00085	.085%
1.08 : 1	.0385	28.3 dB	.00148	.148%
1.10 : 1	.0476	26.4 dB	.00227	.227%
1.20 : 1	.0909	20.8 dB	.00826	.826%
1.30 : 1	.1304	17.7 dB	.01701	1.7%
1.40 : 1	.1667	15.6 dB	.02778	2.8%
1.50 : 1	.2000	14.0 dB	.04000	4.0%
1.60 : 1	.2308	12.7 dB	.05325	5.3%
1.70 : 1	.2593	11.7 dB	.06722	6.7%
1.80 : 1	.2857	10.9 dB	.08163	8.2%
1.90 : 1	.3103	10.2 dB	.09631	9.6%
2.00 : 1	.3333	9.5 dB	.11111	11.1%
2.20 : 1	.3750	8.5 dB	.14063	14.1%
2.40 : 1	.4118	7.7 dB	.16955	17.0%
2.60 : 1	.4444	7.0 dB	.19753	19.8%
2.80 : 1	.4737	6.5 dB	.22438	22.4%
3.00 : 1	.5000	6.0 dB	.25000	25.0%
3.50 : 1	.5556	5.1 dB	.30864	30.9%
4.00 : 1	.6000	4.4 dB	.36000	36.0%
4.50 : 1	.6364	3.9 dB	.40496	40.5%
5.00 : 1	.6667	3.5 dB	.44444	44.4%
6.00 : 1	.7143	2.9 dB	.51020	51.0%
7.00 : 1	.7500	2.5 dB	.56250	56.3%
8.00 : 1	.7778	2.2 dB	.60494	60.5%
9.00 : 1	.8000	1.9 dB	.64000	64.0%
10.00 : 1	.8182	1.7 dB	.66942	66.9%
15.00 : 1	.8750	1.2 dB	.76563	76.6%
20.00 : 1	.9048	.9 dB	.81859	81.9%
30.00 : 1	.9355	.6 dB	.87513	87.5%
40.00 : 1	.9512	.4 dB	.90482	90.5%
50.00 : 1	.9608	.3 dB	.92311	92.3%

$$VSWR = \frac{1 + |\rho|}{1 - |\rho|} = \frac{1 + \sqrt{(P_{rfl}/P_{twd})}}{1 - \sqrt{(P_{rfl}/P_{twd})}}$$

$$POWER RATIO = (P_{rfl}/P_{twd})$$

$$\rho = \frac{VSWR - 1}{VSWR + 1} = \text{REFLECTION COEFFICIENT}$$

$$RETURN LOSS = -20 \log |\rho|$$

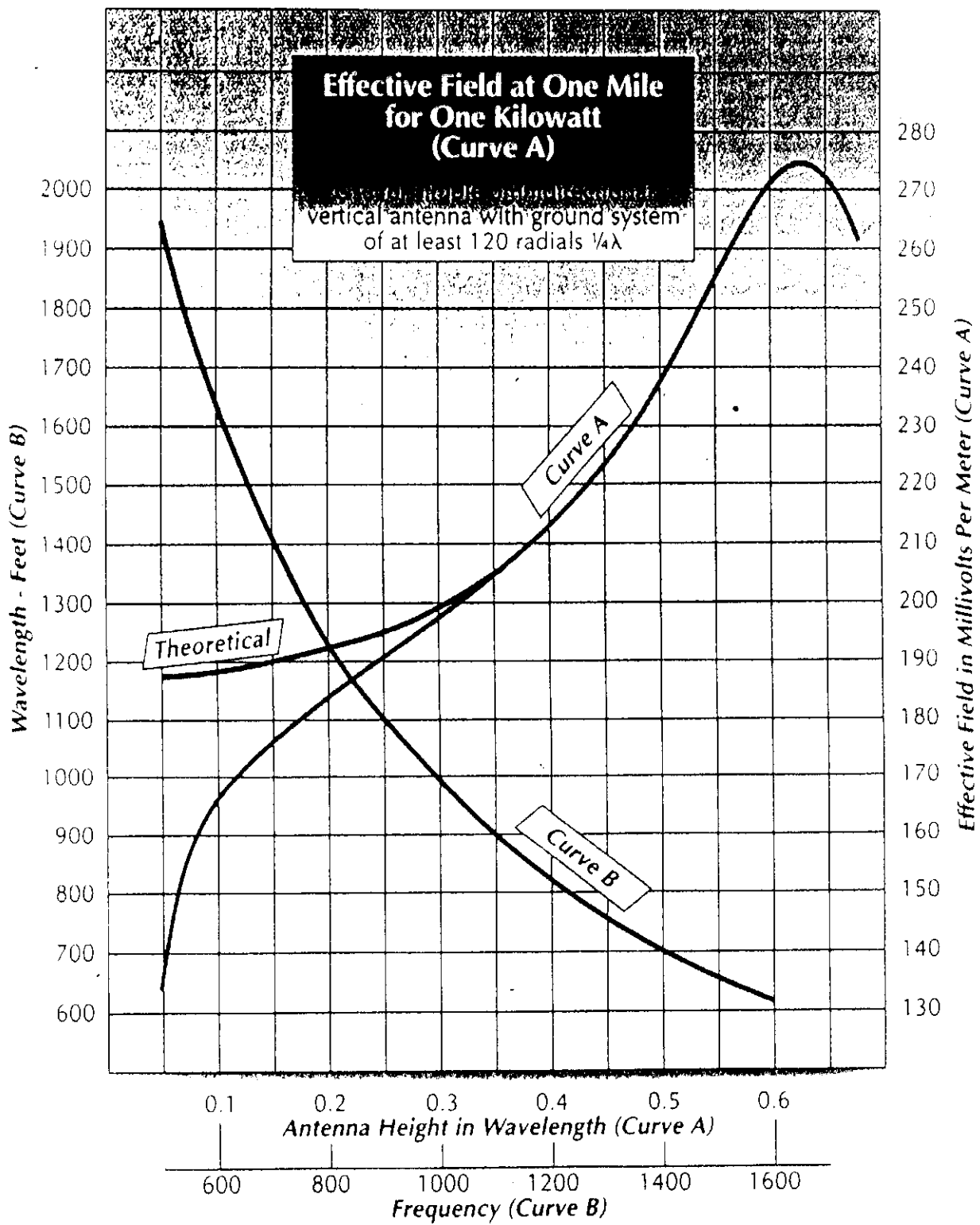

Figure 1. Use this chart to obtain tower height in wavelength and determine the effect of height on radiation.

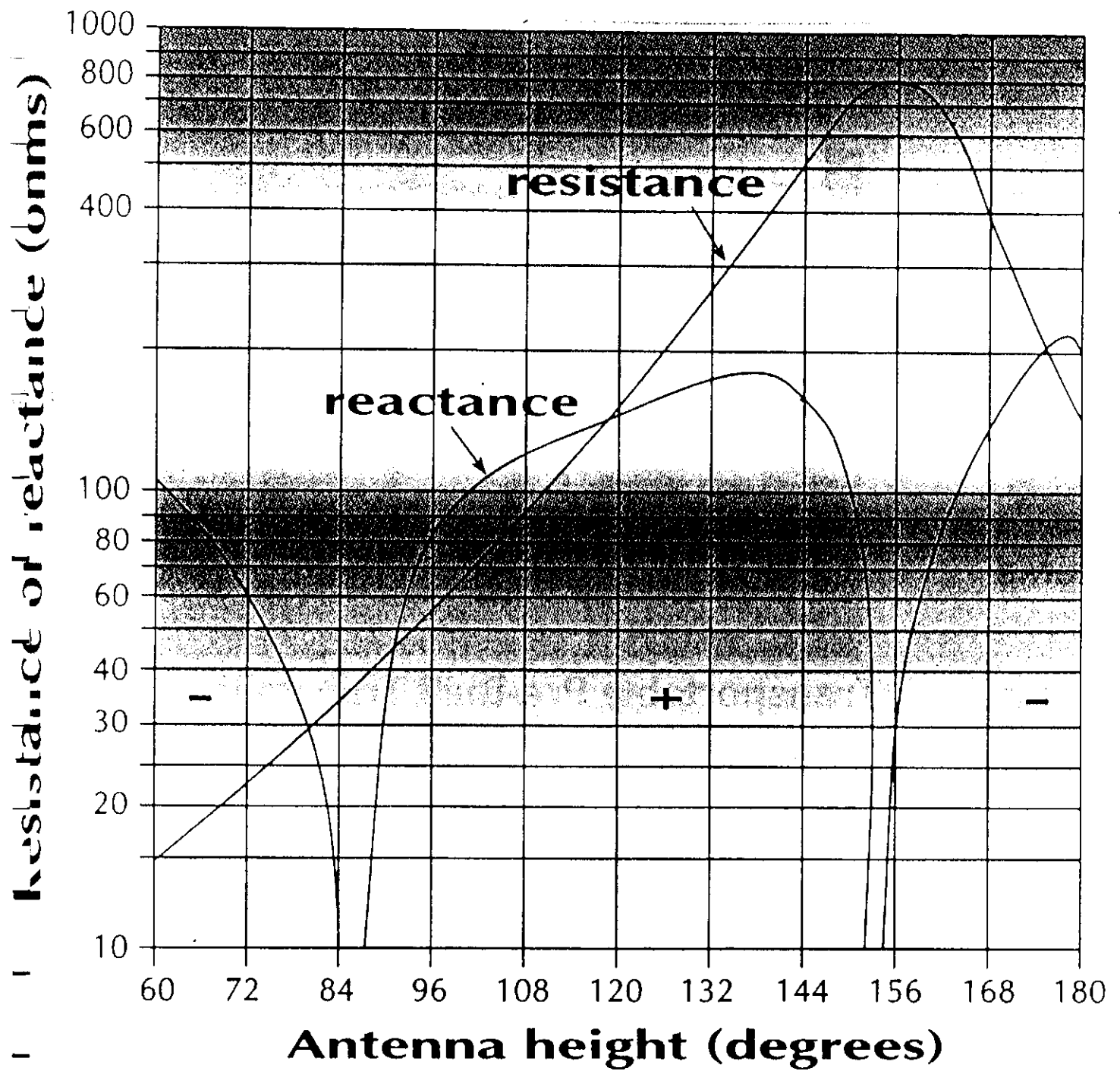
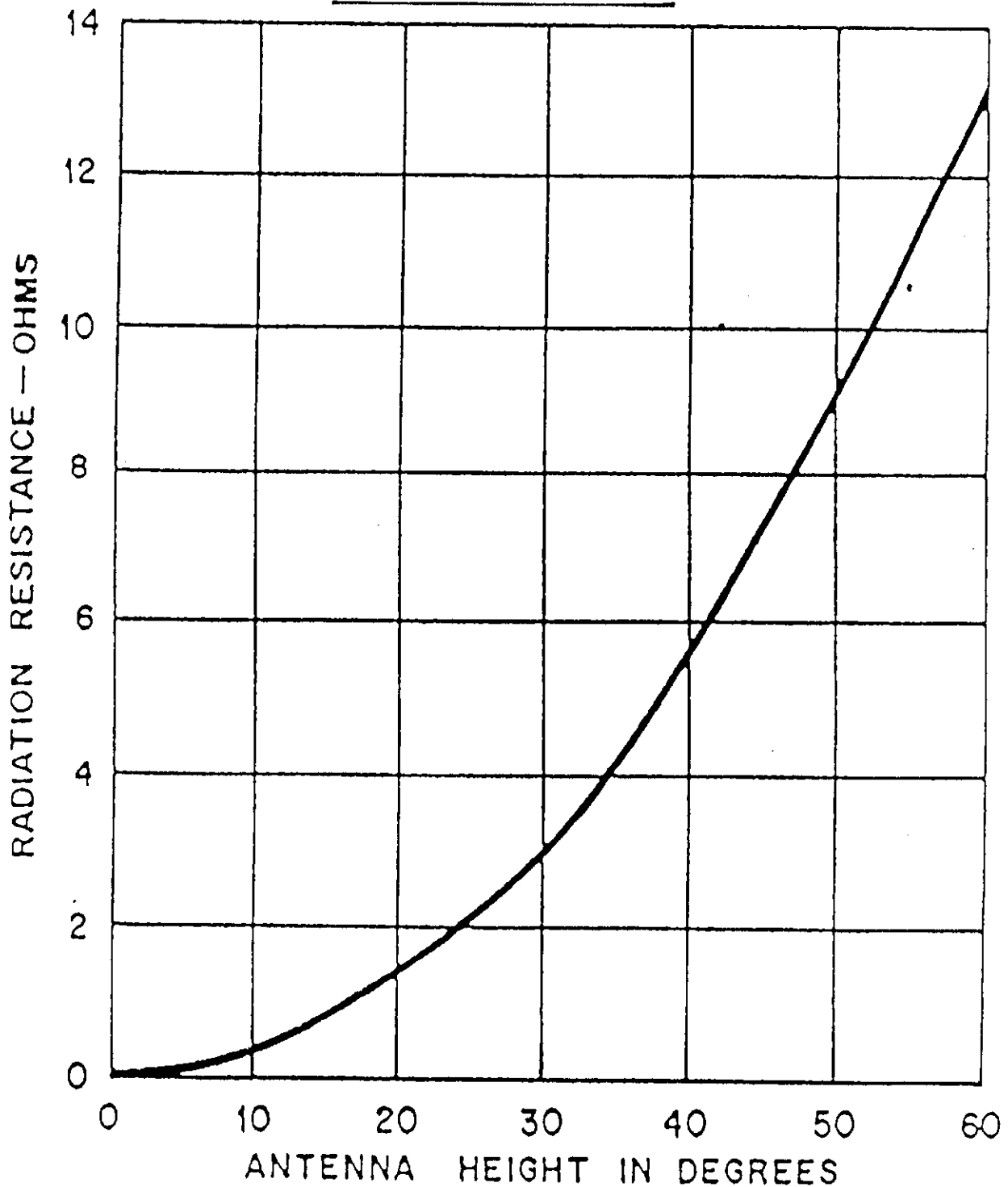

Figure 1. Base resistance and reactance for various antenna heights.

EXTRA SHORT ANTENNAS



Radiation Resistance will be higher in cases where low Frequency Antennas are erected over earth of only Average Conductivity. Figures above are valid for antennas having a perfectly conducting Ground Plane, such as high frequency Antennas, where a Ground Plane can be constructed all of Metal. For A.M. Radio use, the chart gives only a RELATIVE INDICATION, and Readings may be as much as DOUBLE the Resistances shown above.

Courtesy J.R. Cunningham

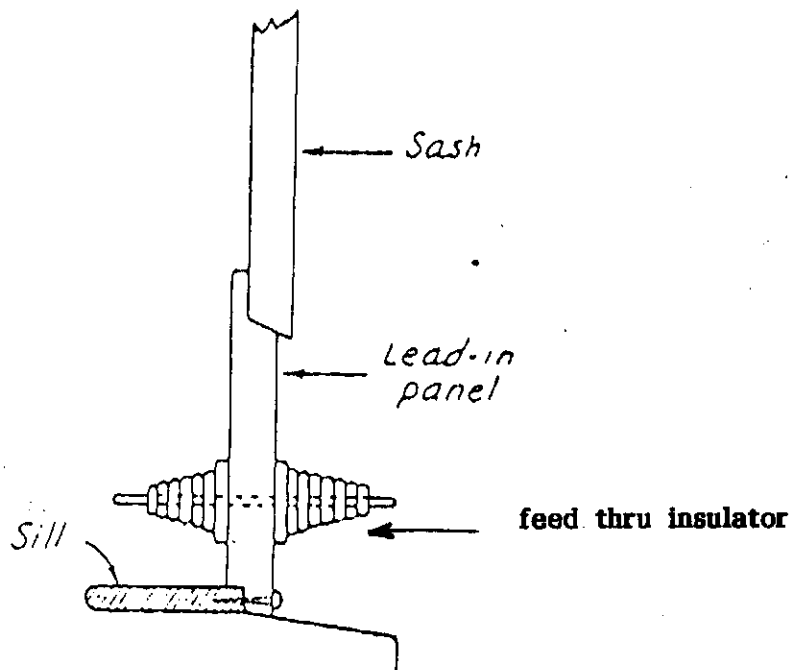
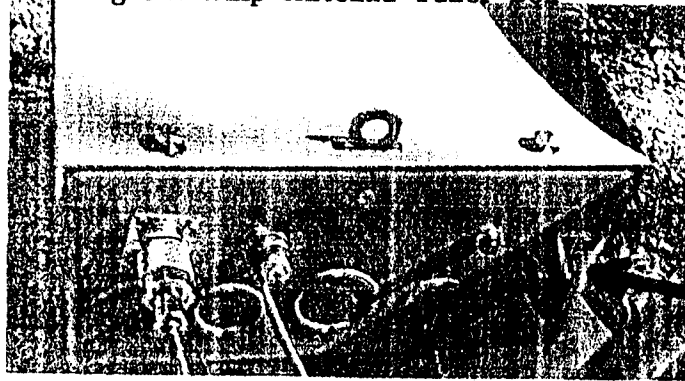

Fig. 14-51—An antenna lead-in panel may be placed over the top sash or under the lower sash of a window. Substituting a smaller height sash in half the window will simplify the weatherproofing problem where the sash overlaps.

### Cunningham Whip Antenna Tuner Box



Tuning Knob  
(tune for Max.)

### BOTTOM VIEW OF TUNER BOX

At the bottom of the Tuner Box, you can see the Coaxial Cable attached to the Left side. As you go to the Right, you will see the Brass Ground Screw with wire attached (user must supply this wire). Then, on the Right Side of the Bottom, you see a "little red light," and next to it a "Tuning Knob." With the Transmitter on "LOW" this must be adjusted for 'MAXIMUM GLOW' on the red lamp. This should be done with the Box held upright and away from any metal objects, with Ground Wire attached to the Brass Screw.

Close the lid on the Tuner Box, turn off Transmitter, and raise the Antenna to it's full height of AT LEAST 20 Feet above Ground Level!

If Antenna is not high (20 Feet or more) it will not Radiate properly!

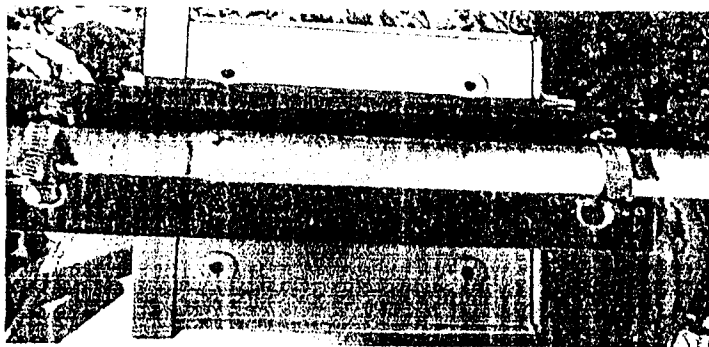

### BACK VIEW

In this Back View, you see the way the Mounting Clamps attach through the Mounting Bracket and onto the Mounting Pole (you must supply the mounting pole).

This Bracket may be an insulator (as provided by mfr.) but either a small diameter Metal Pole or Insulated Pole may be used to provide the Tuner Box and Antenna sufficient clearance above Roof Tops. This Mounting Pole may be attached to a larger pole or structure, such as a Roof Top or Power Pole. Overall height must be at least 20 feet above Ground, but 40 feet or more gives much better performance!

**DO NOT MOUNT WITHIN 10 FEET OF A LARGE METAL ROOF OR METAL BUILDING - IT WILL DISTORT YOUR SIGNAL STRENGTH.**

## MAKE YOUR OWN ANTENNA TUNER

1. Make a Coil with 30 turns of Insulated Wire over a PVC Pipe with a slot cut out in the middle as shown for Tuning. Use Big Wire and PVC Pipe for high Power over 50 Watts. Use a 1 inch O.D. Pipe for Low Powers under 50 Watts.
2. Connect Transmitter 50 Ohm Coax as shown to the coil
3. Connect a VARIABLE CAPACITOR of 300pf. as shown. Use a little one for powers under 50 Watts. Use a big tuning (Variable) Capacitor for higher Powers.
4. Adjust under Power for brightest glow on a NE-2 neon Lamp (buy at Radio Shack). Part number: 272-1100.

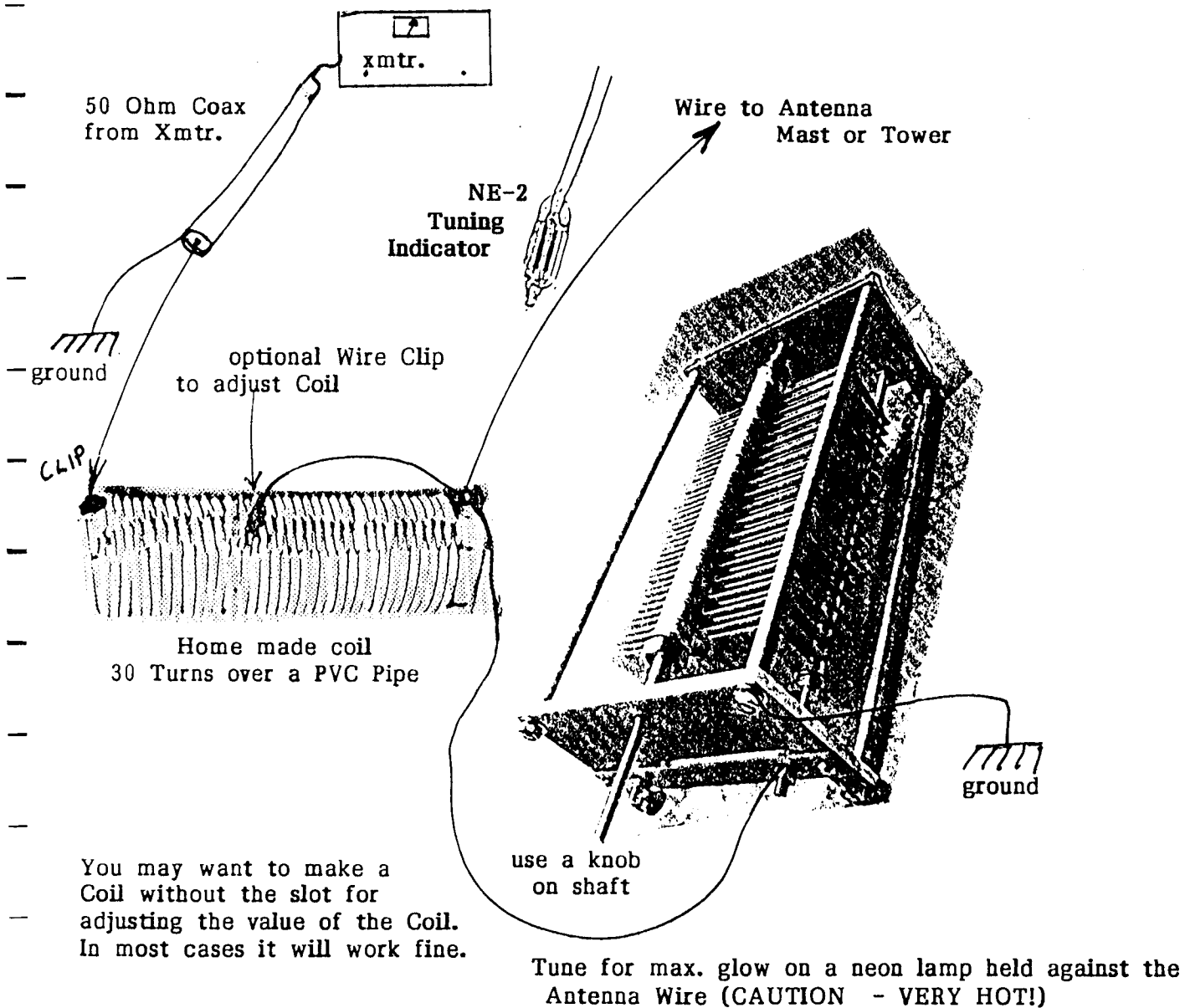

PVC PIPE "FLUTED" COILS

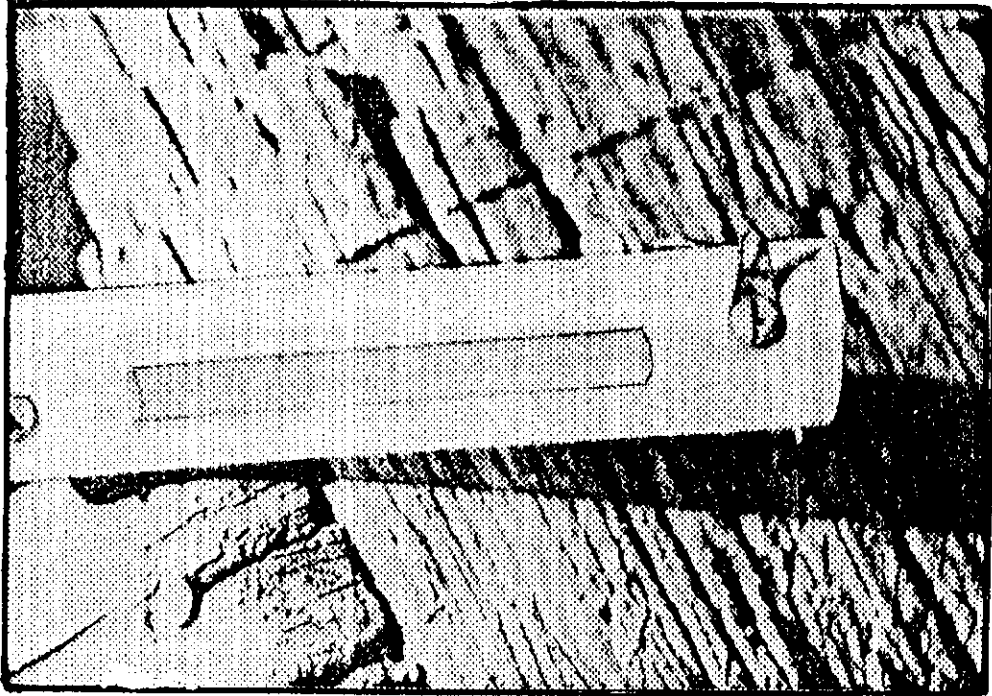

"FLUTED" AREA IS CUT OUT WITH A SMALL SAW  
THIS ASSURES ROOM FOR INSERTING R.F. CLIP AFTER  
COIL IS WOUND.

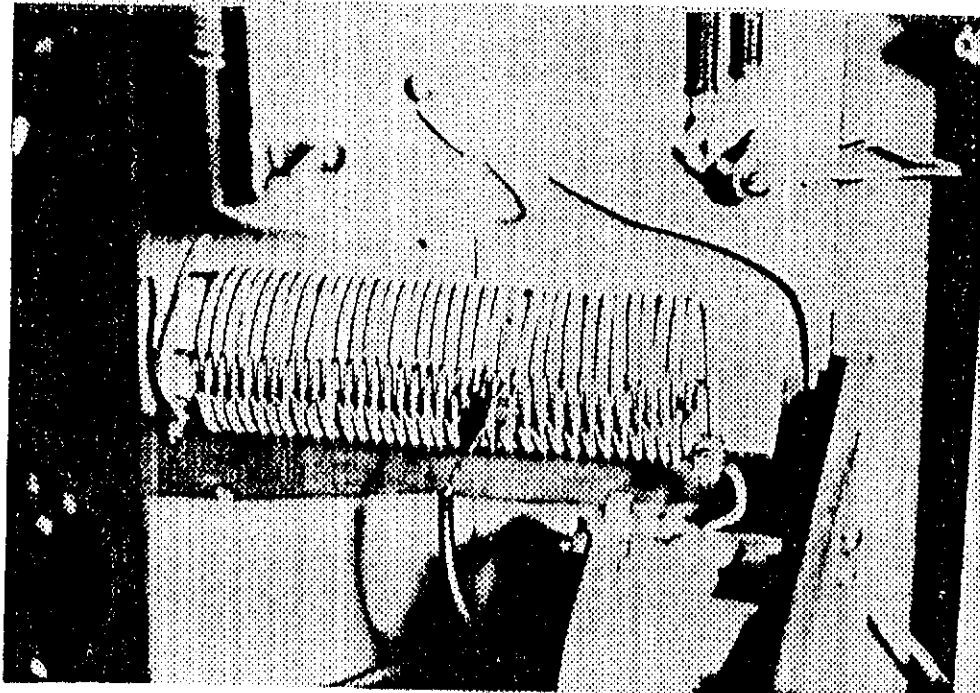

THE INSULATED WIRE IS BARED ACROSS THE "FLUTE"  
FOR INSERTION OF THE R.F. CLIP. (#10 WIRE SHOWN)



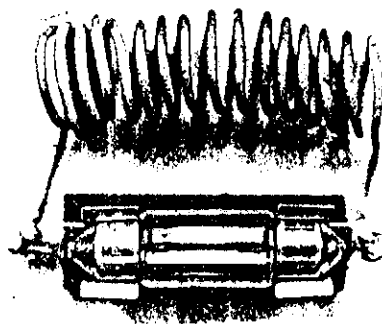
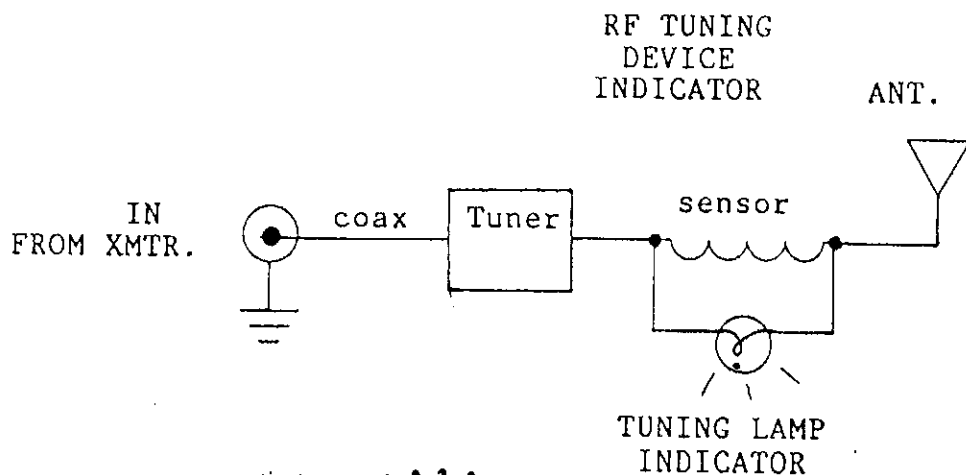

THEACTUAL SIZE PHOTO

This device may be placed between the Antenna tuner and the Antenna itself, at the point where the lead in wire attaches to the tuner. When maximum RF Current is found, the lamp will be at its maximum glow. After the Antenna is tuned, the lamp may be removed, or left permanently in the circuit.

#### PARTS

The sensor wire consists of 5-15 turns of #18 - #10 coated wire, depending on how much current is to be drawn into the antenna system. This is coiled into 1/4 inch to 3/4 inch diameter coil. Across it is placed a small lamp such as the R5604 dome lamp, the type used in automobiles. This is shown mounted in a fuse block (sold at auto departments in stores). This is isolated from grounds and shorts. The device consumes almost no power and may be left in the circuit after tuning is accomplished. The actual resistance of the total assembly is about .2 ohms and works well for frequencies up to 3 MHZ. At frequencies higher than this, the number of turns should be reduced to 2-7 turns, depending on the frequency of operation (30 MHZ upper limit for the device).

USING THE UNIVERSAL TUNER  
TO TUNE TOWERS  
AND  
WIRE ANTENNAS



TUNING

After the Unit is connected to your antenna system (use plenty of grounding) you may turn the transmitter on "LOW" and begin by:

A. PUT THE WIRE CLIP ABOUT 3 POSITIONS FROM THE right hand end OF THE COIL. This allows a little coil inductance to be present, since it is needed in nearly all installations.

B. WITH TRANSMITTER ON, ROTATE THE TUNING SWITCH. YOU WILL SEE THAT IT HAS A TOTAL OF 6 POSITIONS. ONE OF THESE POSITIONS WILL GIVE THE TUNING LAMP SOME "GLOW." Leave the switch in this position until another coil setting is tried. Try several coil settings, moving the WIRE CLIP to another point, then moving the tuning switch through all 6 positions, finding the place where both COIL AND SWITCH are set for MAXIMUM GLOW on the lamp.

C. TURN THE LAMP OFF AND CLOSE UP THE BOX AFTER BEST TUNING IS ACCOMPLISHED.

IF THE ANTENNA IS SHORTENED, ALTERED IN SOME WAY OR LENGTHENED, REPEAT THE ABOVE STEPS, ALWAYS TUNING FOR MAXIMUM GLOW ON LAMP!

# The Universal Tuner Schematic

by J.R. Cunningham Transmitters

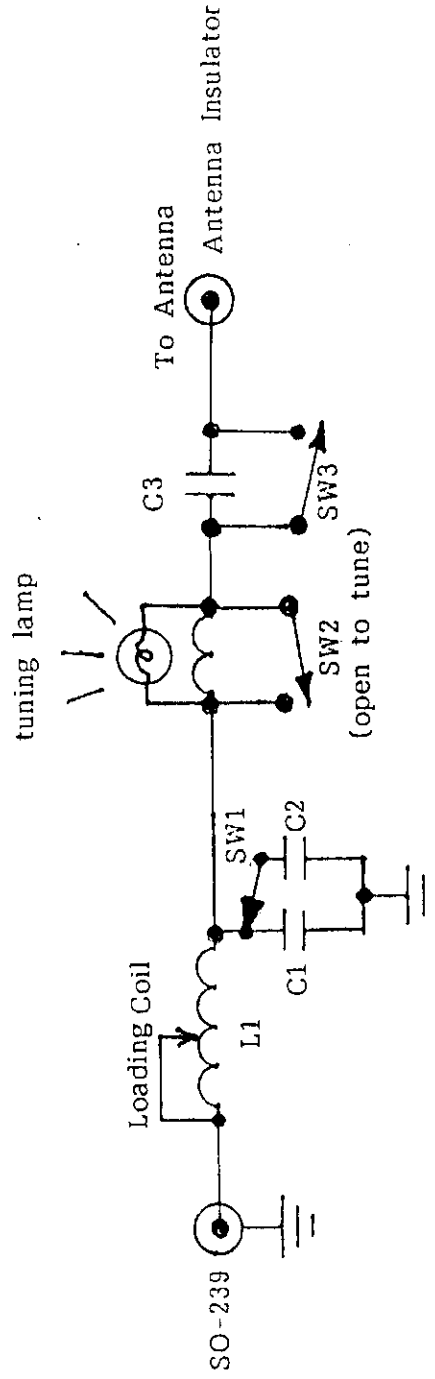

Adjust L1, C1, C2 and C3 for Max. Glow on TUNING LAMP. Close SW2 afterwards for normal operation. C3 is for isolation purposes only and is not normally used. SW3 is normally closed.

MODEL CM 30 - 50 ANTENNA TUNER

1. Matches Quarter Wavelength Towers and Wires to Transmitter. Matches Transmitter to CARRIER CURRENT LOADS for Carrier Current Broadcasting.
2. Adjusts 0 - 50 Watts Power, 500 KHZ through 1710 KHZ.
3. Reduces Harmonics - Maximizes Antenna Efficiency.

The CM 30 - 50 UNIVERSAL ANTENNA TUNER  
MOUNTS OUTDOORS ON A POLE, WALL OR  
MAY BE MOUNTED INDOORS  
WITH THE LEAD IN WIRE PASSING  
THROUGH THE WALL OR WINDOW.

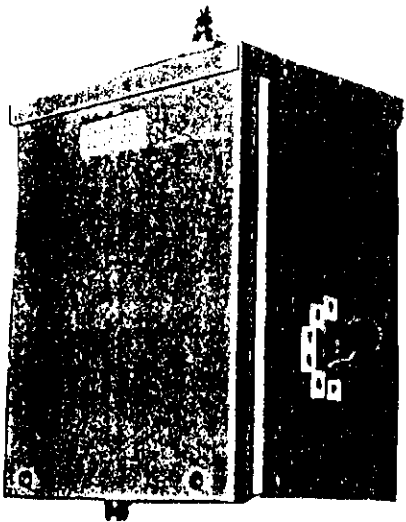

OUTSIDE VIEW

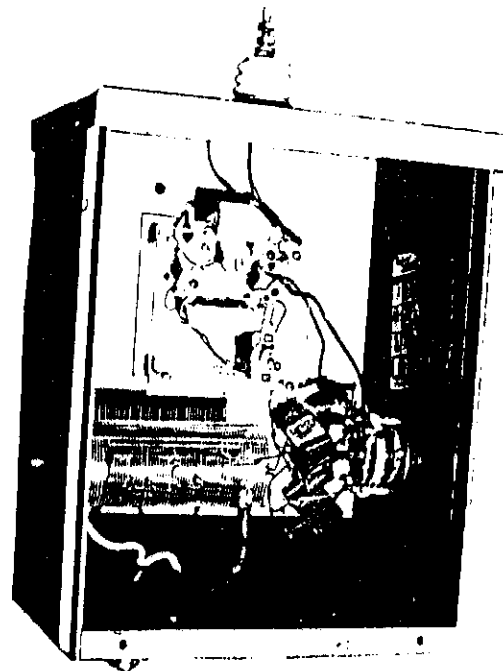

INSIDE

THE UNIVERSAL A.M. ANTENNA TUNER  
500 KHZ - 1710 KHZ  
ADAPTABLE TO 30 MHZ

## "POOR MANS" LEAKY CABLE DEVICE

(Orig. Idea by Ken Prooyen)

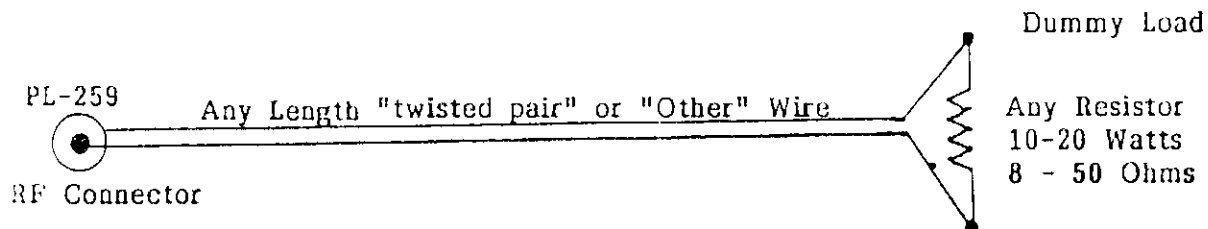

### CARRIER CURRENT "LEAKY CABLE"

Any Twisted Pair can be used as a Leaky Cable Device when connected as shown, provided that it is not a "shielded" cable. I will cover "SHIELDED" later. Not only will Twisted pair wires work well for any distance of "Leaky Cable" System, but ordinary "ZIP" CORD, LAMP CORD, TELEPHONE LINE STYLE WIRE (1 pair only) and any "balanced" type wire is very good at carrying the RF Carrier along its entire length, be it a few feet or several miles! There is a "catch" to it (as shown above). The Wire Pair must be loaded at its far end by a resistor of no lower value than 8 ohms and no higher value than 50 ohms (under most situations). I have found that in special cases, up to 300 ohms will load, but generally you lose out by exceeding 50 ohms. The Transmitter is most effective at frequencies below 1 MHZ, but I have seen this method work even at 100 MHZ, under much shorter distances. The "MATCH" to the Cable may not be perfect, but by allowing for the right Resistive Value at the end of the line, this can usually be lowered to a safe level. If too much SWR is present at the "send" end, you may damage your Transmitter. The F.C.C. requires the same Compliance with this as with all other Part 15 Devices. Field Strength is to be measured at 100 feet (30 M) from the Cable and must not exceed 24,000 Divided by (F) Freq. in KILO Hertz. This will provide a figure in MICRO Volts Per Meter as the upper limit for Field Strength.

"SHIELDED" Wire can be used by making the "shield" the outer wire and use the Inner Wire for the Center (HOT) wire coming from the Center Contact of the Plug.

## INSTRUCTIONS

This TWISTED PAIR wire length is Field Tested as an artificial DUMMY LOAD for the AM Frequencies found between 1500 and 1710 KHZ in the AM Broadcast Band. It is designed to radiate a LIMITED FIELD STRENGTH in accordance with Part 15 of the Rules and Regulations of the Federal Communications Act regarding CARRIER CURRENT BROADCASTING WITH LEAKY CABLE.

This Section or length of wire or cable is capable of a low level of Radiation, propagating approximately between 14 and 16 microvolts per meter at 100 feet distance from the radiating element composed of the cable itself. If the wire is suspended horizontally or vertically above the floor space or earth, it will provide a Signal suitable for reception by the average Radio Receiver at a maximum distance of about 500 feet. At 100 feet from the LEAKY CABLE SECTION PROVIDED, Signal Strength should be at or about 5 to 10 times that necessary for reception on an AM Radio receiver.

Increased lengths of LEAKY CABLE will improve coverage, up to 5 miles in length, and terminated with the appropriate resistive DUMMY LOAD at its far end, for use in situations where CONTROLLED RADIATION is desirable.

NO LICENSE IS REQUIRED FOR THE USE OF THIS FORM OF BROADCASTING, providing no interference is given to Licensed Broadcast Services: AM, FM, Short Wave or Aviation, nor is a License available at any cost. Part 15 of the FCC Rules and Regulations regarding Field Strength Limitations must, however, be carefully observed.

FIELD STRENGTH LIMITATIONS FOR the LEAKY CABLE form of AM BROADCAST SERVICE IS FOUND BY THE FORMULA:

$24,000/\text{Freq. in KILO Hertz measurable at a distance of 100 Meters from the Radiating Cable!}$

JAMES R. CUNNINGHAM

May 3, 1994

RT. 2 BOX 113B

STONEWALL, OK 74871 USA

## HOW GREAT A DISTANCE CAN I EXPECT?

The following figures are based on REAL LIFE EXPERIENCE and ACTUAL CASES.

RULES OF BROADCAST ANTENNAS: When you multiply transmitter power FOUR TIMES, you reach out only DOUBLE THE DISTANCE.

1. 250 Watt A.M. Radio Broadcast Station with a good Antenna System will reach 30 miles in every (all) directions. With a poor Antenna - 13 miles.
2. A 500 Watt Station with a good Antenna System will reach 43 miles in all directions. The same Transmitter with a poor Antenna - 18 miles.
3. A 1000 Watt Radio Station with a good Antenna System will reach 60 miles in all directions. With a poor Antenna - 25 miles.
4. A 5000 Watt Radio Station with a good Antenna System will reach in all directions 130 miles. With a poor Antenna System - 56 miles.

## SQUARE MILES COVERED

In the above four examples you have the distance in all directions. The real Area covered is shown here through the use of the Formula:  $A=\pi R^2$ .

1. 30 miles in all directions equals 2826 square miles.
2. 43 miles in all directions equals 5806 square miles.
3. 60 miles in all directions equals 11,304 square miles.
4. 130 miles in all directions equals 53,066 square miles!

\* Many large Cities have over 5000 people per square mile. A single 250 Watt Radio Station could cover a City of over 1-1/2 Million People!

\* Statements by Radio Engineer James R. Cunningham Box 8, Stonewall, Ok 74871 United States of America

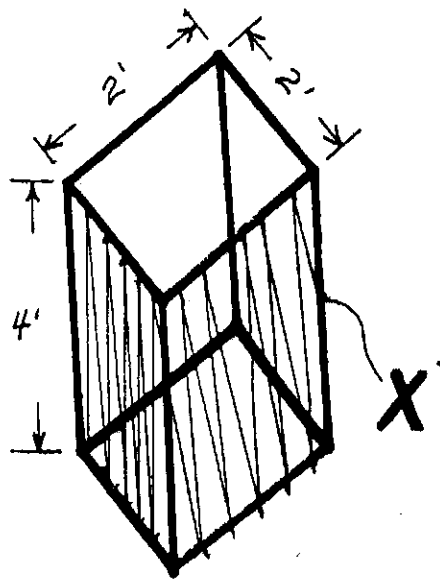

VERTICALLY POLARIZED  
WIRE CAGE ANTENNA

This antenna is for use at standard A.M. Broadcast Frequencies, but may be used at higher frequencies by scaling down the entire structure and using the appropriate length of wire strung up in a vertical fashion as shown. The Feed point is marked with the "X" and connects to a vertical wire Lead In which in turn connects to the ANTENNA TUNER BOX. The tuner may be a loading coil design, or a standard "T" Network as is commonly used for these purposes.

This antenna requires a COMPLETE GROUND SYSTEM with ground radials directly beneath it. It provides a CIRCULAR RADIATION PATTERN of VERTICAL POLARITY. It gives approximately the same gain and Field Strength as Horizontal Wire Antenna of the same number of feet of wire as stretched out between poles, if the proper ground radial system is used beneath it.

Advantages are obvious:

1. Smaller size. It may be attached to a pole above a roof top or mast mounted.
2. It is light weight, easily transported, broken down or stored.
3. It is inexpensive and easy to build from PVC Pipe or bamboo/wood frame.
4. It is small enough to use in the inner city on a roof top with counterpoise.



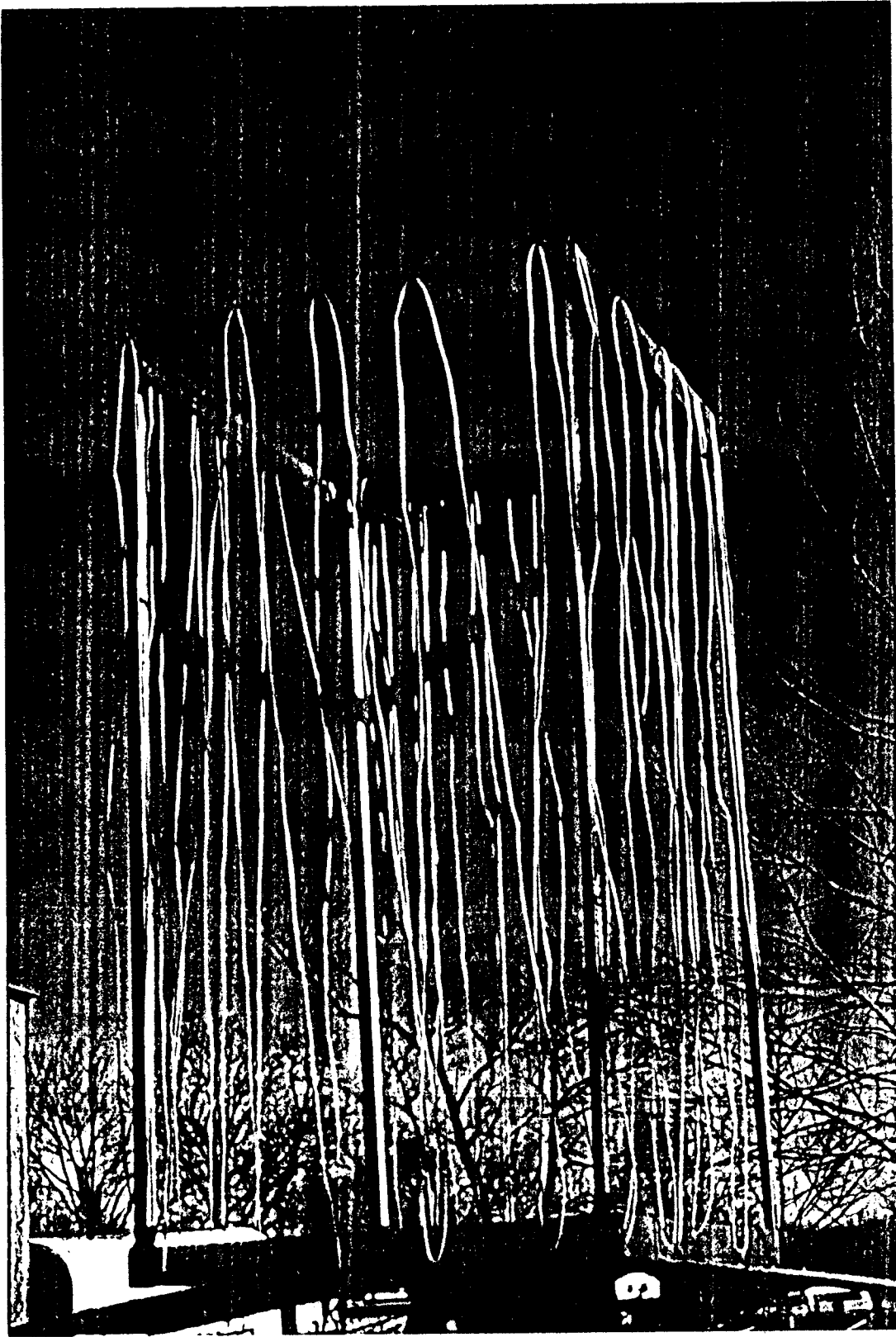

#### WIRE CAGE ANTENNA

This Antenna gave a field strength Reading of 5 MVM at a distance of 1 mile, on 1/18/1997. Power output was 20 Watts from the CM 30-50 Transmitter. GROUND SYSTEM consisted of 1 elevated Ground Radial of 150 feet with a ground stake at the far end. No other grounding was used. The Universal Antenna Tuner was used for tuning.

## ADDITIONAL INFORMATION

The Wire Cage Antenna shown on the preceding page is constructed using PVC Pipe sections, wood or bamboo for a frame. The wire can be any size from #10 down to #22 gage wire, so long as there is sufficient strength in the copper wire to withstand any winds that may be encountered in actual use. If the antenna is raised in height, the operation improves, however, it may be concealed inside an attic or other existing structure of sufficient height to assure good performance. This antenna must not be placed in close proximity to metal roofs, girders, or other wires which may alter its efficiency. It may be supported by a mast, such as used for a TV antenna. The Wire Cage Antenna may be held in place using rods clamped or wired to its side structure, or a bottom and top may be made from plywood or plastic and used for mounting on a pole passing through its center.

The wire is started at one side in the middle (as shown) and run up and down in a vertical fashion as shown. Wire length may be found using the formula:  $234/Fmhz$ . For example, if your frequency is 1500 (1.5MHZ) divide 234 by 1.5 for 156 feet of wire to be installed on the "cage." Each side of the "cage" usually has 5 or 6 tie points for the wire at top and bottom. These are usually wood screws positioned about 4-5 inches apart along the top and bottom edges of the frame. The wire is run up and down from screw to screw and wound 2 turns on the shaft of each screw. This assures that the wire will not come off or loosen at some later time. Up to 300 feet of wire may be placed on the "cage" depending on frequency. Only ONE END of the wire is attached to the "TUNER." The other end hangs free. The ANTENNA TUNER may be built into the cage antenna, if the cage is to be located where it is easily accessible for tuning. The tuner is out of the weather or enclosed in weather proof box. Use 50 ohm coax all the way from the transmitter to the tuner, then connect a short lead in wire from the tuner to the Antenna at point "X."

### A SIMPLE TUNER

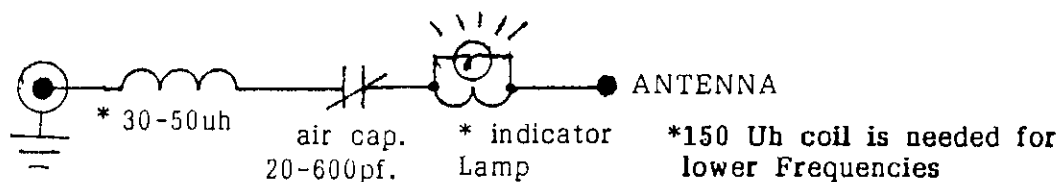

The Tuner may be built from readily available parts. The lamp glows when tuned. The following Page describes construction of the tuner and its indicator Lamp.

The Cunningham Antenna  
For Low Power AM

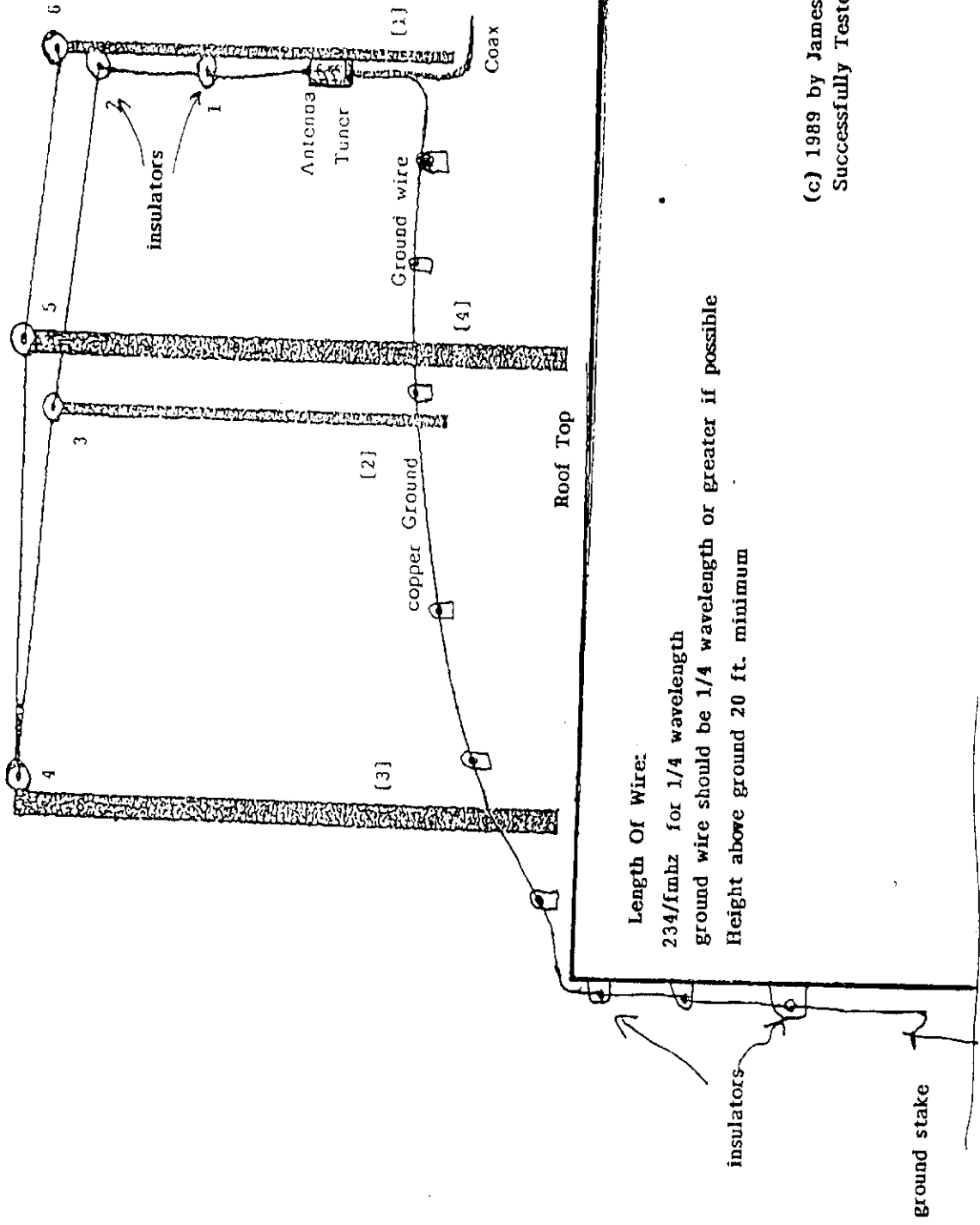

Length Of Wire:

$234/f$  mhz for  $1/4$  wavelength

ground wire should be  $1/4$  wavelength or greater if possible

Height above ground 20 ft. minimum

(c) 1989 by James Cunningham  
Successfully Tested up to 1KW

Cunningham LPAM Counterpoise  
ANTENNA

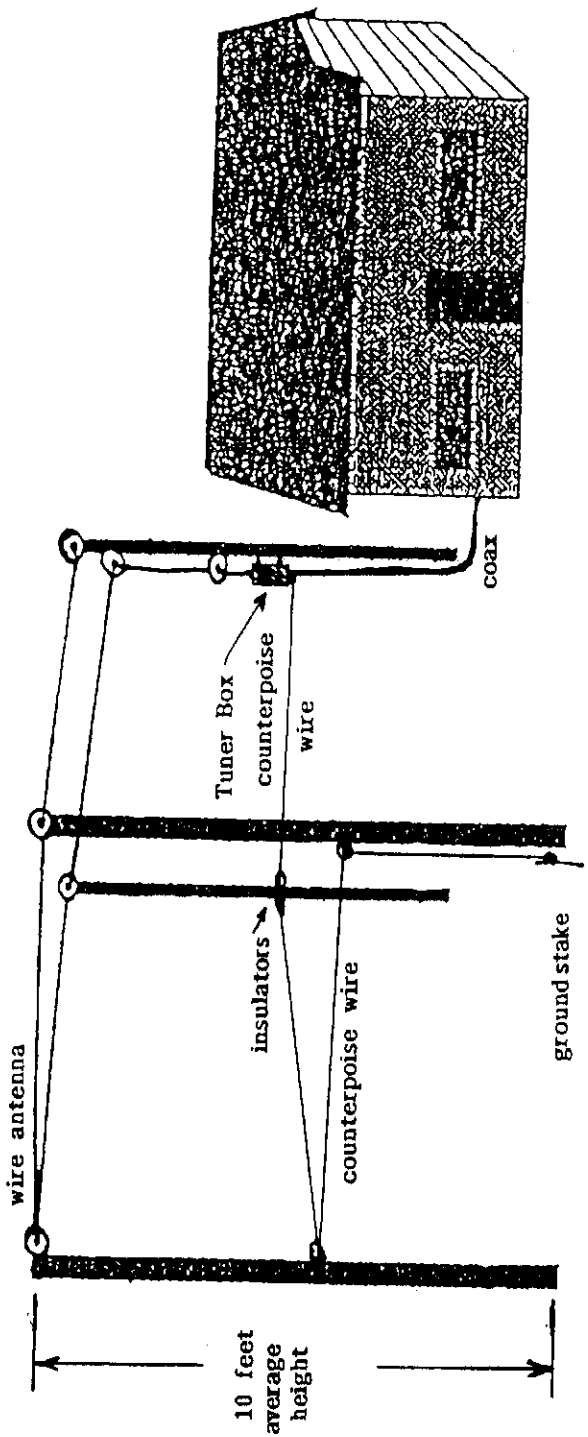

(c) Copyright 1993  
James R. Cunningham

NOTES

The Counterpoise AM Wire Antenna shown here is a modified DRRR configuration. Because of the close proximity to Earth, it has a VERTICAL POLARIZATION. The counterpoise wire is elevated above ground 3-4 feet average and the Poles are 6-8 feet high above ground level. These poles may be up to 20 feet in height if desired and the counterpoise may then be placed above 6-8 feet to avoid being in the way, and yet the DRRR effect is retained. This Antenna will serve quite well under most circumstances. The LENGTH of wires should be at least 1/4 Wave Length for best effect.

Please note: This Antenna can be used without the TUNER BOX if a FEED LINE is run directly from the back of the Transmitter, through the wall, and to the Antenna "Hot Wire." This FEED LINE is VERY HOT and must be insulated from walls or windows using a FEEDTHRU. This will eliminate the risk of A FIRE. The Length of the FEEDLINE must be counted as part of the total antenna wire length or Tower Height.

## STATIC DRAIN CHOKE

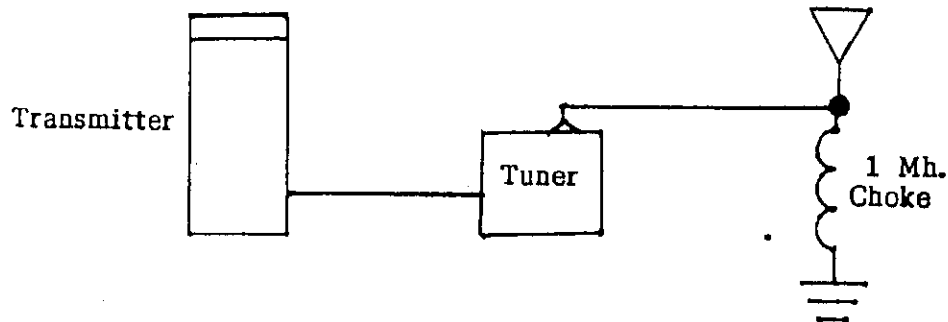

THE STATIC DRAIN CHOKE IS USED FOR THE PURPOSE OF DISCHARGING ELECTRICAL CHARGE BUILDUP TO EARTH GROUND, FOR THE PURPOSE OF PROTECTING VALUABLE TRANSMITTERS AND TUNING DEVICES FROM LIGHTNING DAMAGE OR HIGH VOLTAGE DAMAGE.

## SERIES FED ANTENNAS

SERIES FED WIRES AND TOWERS ARE INSULATED FROM EARTH GROUND, THEREFORE HIGH VOLTAGE CHARGES BUILD UP BETWEEN THE ANTENNA AND THE EARTH ITSELF. THESE CHARGES ARE USUALLY IN THE RANGE OF HUNDREDS OF VOLTS, AND SOMETIMES TENS OF THOUSANDS OF VOLTS (DURING STORMS, ETC.).

THE STATIC DRAIN CHOKE HAS ENOUGH INDUCTANCE IN ITS WINDING TO HAVE NO EFFECT ON THE RADIO SIGNALS IN THE ANTENNA ITSELF, YET BEING DIRECTLY CONNECTED TO EARTH GROUND, PROVIDES A SHORT CIRCUIT TO STATIC VOLTAGE BUILDUP. IT WILL PROVIDE PROTECTION FOR YOUR RADIO EQUIPMENT, EXCEPT FOR A DIRECT LIGHTNING STRIKE. LIGHTNING PROTECTION MAY BE OBTAINED THROUGH THE USE OF (1) A LIGHTNING LOOP, AND (2) THROUGH A SPARK GAP AT THE ANTENNA FEED POINT (OUTSIDE THE BUILDING). THE CHOKE MAY BE LOCATED INSIDE A TUNING BOX OR AT THE BASE OF THE TOWER. ALMOST ANY CHOKE WILL WORK, BUT THE WIRE SHOULD BE CAPABLE OF AT LEAST 1 AMP CURRENT. IF LOW POWER IS BEING BROADCAST. FULL POWER STATIONS SHOULD USE BIG COMMERCIALY AVAILABLE CHOKES MADE FOR THE PURPOSE.

A SIMPLE BROADCAST  
ANTENNA EXAMPLE

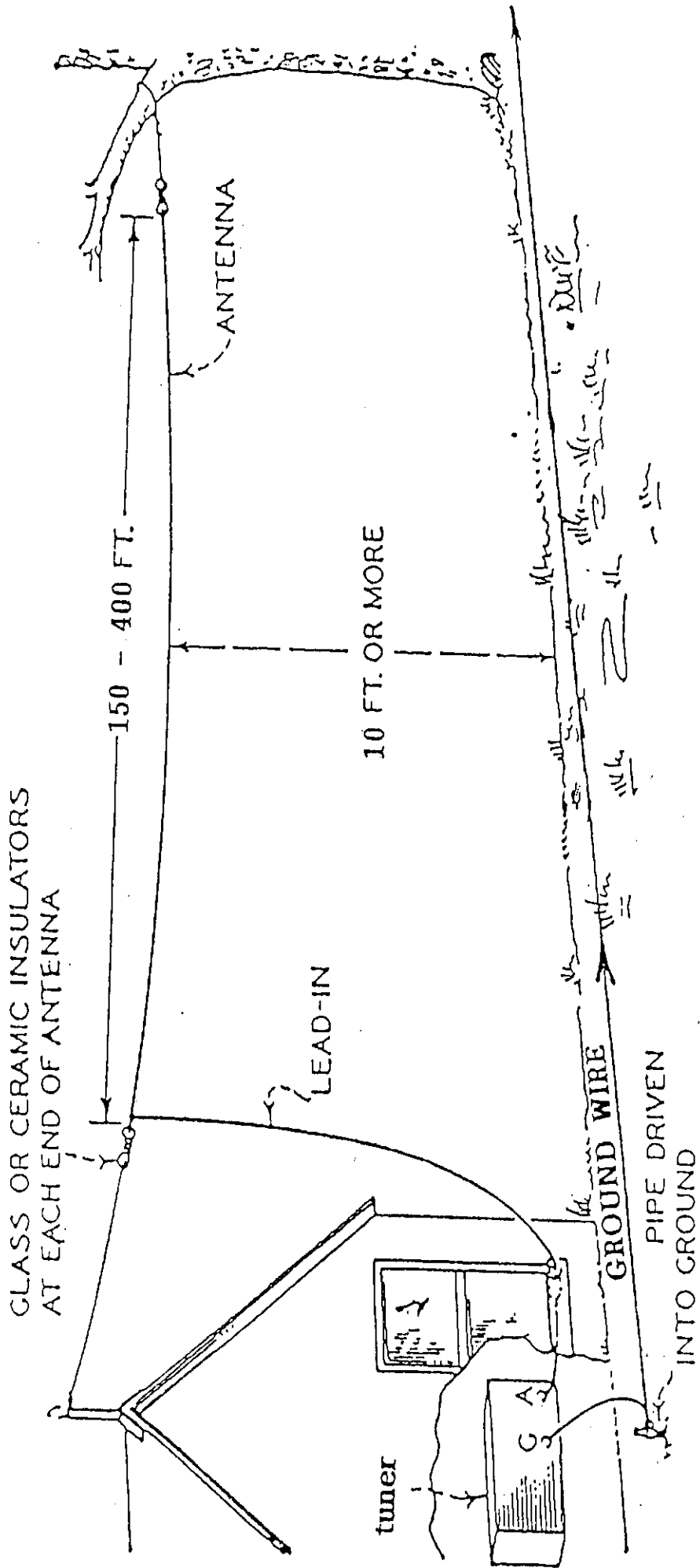

## WIRE ANTENNA DESIGN

Shown below is a basic long wire antenna design which is very dependable and easy to construct. This type antenna can be used with all of the reflector/director designs given in this Book and there are less chances of making a mistake using this design, so if you are not a well experienced antenna builder, please use this design rather than the others.

The wire may be any gauge strong enough to support its own weight and carry the antenna currents specified for the transmitter used.

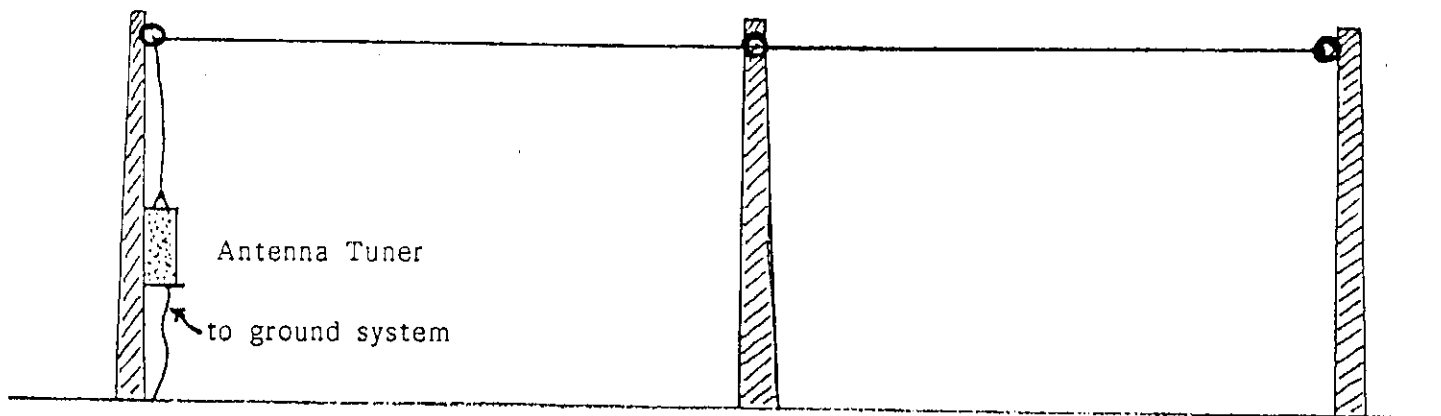

A good ground system is needed beneath this antenna design with radials going out from beneath the tuning box in all directions to a distance of  $1/4$  wavelength or greater for best performance. You may use a single  $1/4$  wavelength wire going from the antenna tuner out to the left side of the antenna for emergency operation on a temporary basis until a better ground system can be built. Best operation of the antenna requires 120 ground radials of  $1/4$  wavelength buried just beneath the soil. This antenna can be any desired length, but  $1/4$  or  $1/2$  to  $5/8$  wavelength is normal. Longer wavelengths provide directional patterns and are not used with Standard Broadcast Frequencies unless quite large portions of land are available. The antenna wire works very well at heights above 50 feet, but great results are obtainable at distances as low as 10 feet above ground level!

You can multiply your antenna's efficiency by using the reflector/director technique described in the Book.

IDEALIZED GROUND SYSTEM  
FOR THE WIRE ANTENNA

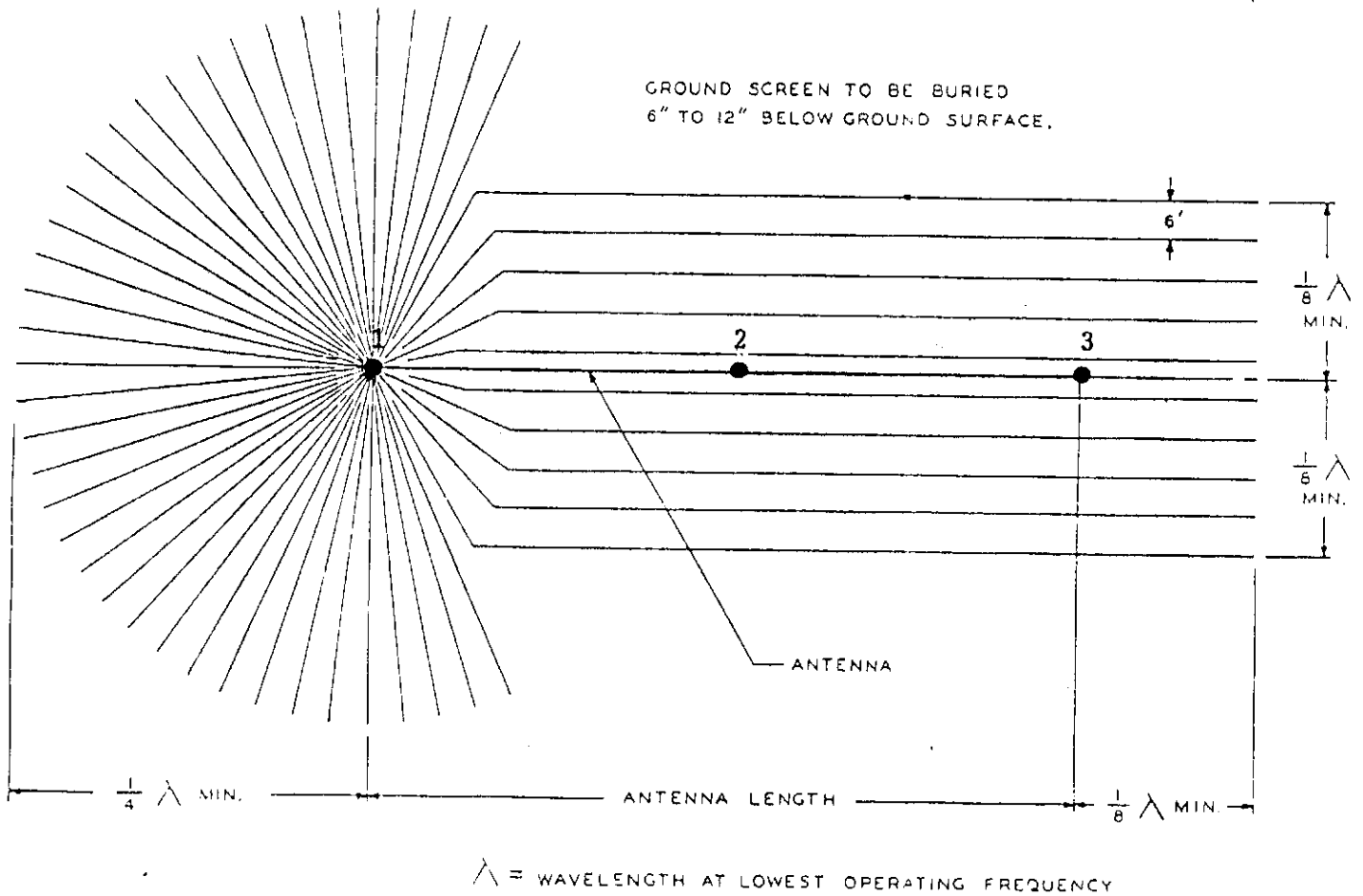

The Idealized Ground System is laid out as shown above. An Aerial View depicts a total of 49 1/4 Wavelength Ground Radials placed as Illustrated.

Each wire is buried about 6 inches deep and is connected to the Main Ground Strap or Wire coming from the bottom of the Antenna Tuner. Please notice that Pole Number One in our Drawings is the location of the Antenna Tuning Box as well as the Center of the Radial System. Going out from there (to the Right) is located the Antenna Wire with its supporting Poles. This may be 3 or 4 in number, but nothing prohibits using as many as deemed necessary, so long as the Antenna Wire is on Insulators. The Antenna Wire must not be connected on its far end, but floats freely on its Insulator. The other end (Left Side of Illustration and center of Radials) is connected to the top of the Antenna Tuner.



MOST PRACTICAL DIRECTIONAL  
A.M. RADIO ANTENNA

SHOWN HERE IS A DIRECTIONAL ANTENNA FOR A.M. RADIO USE WHICH IS EFFECTIVE AT FREQUENCIES ABOVE 1100 KHZ. AND IS COST EFFECTIVE. WIRE SIZE MAY BE FROM #18Gage TO #4Gage, AS CONVENIENT. THE DOWNWARD SLOPE SHOULD BE ABOUT 10 or 15 DEGREES FOR BEST EFFECT. POLES MAY BE SPACED AS IS CONVENIENT. THE TOP WIRE IS INSULATED FROM THE POLES AND MAY BE PLASTIC COVERED OR COATED.

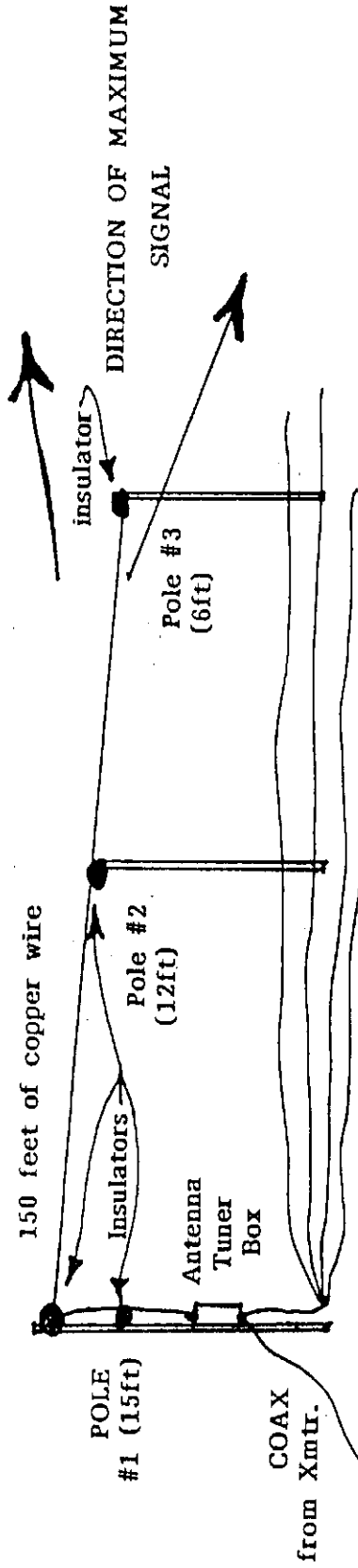

USE AT LEAST 4 WIRES FOR THE GROUND/COUNTERPOISE OF 150 FEET IN LENGTH AS A STANDARD LENGTH. YOU MAY USE "GROUND STAKES" OR MORE WIRES FOR EVEN BETTER RESULTS. IT IS IMPOSSIBLE TO GET TOO MUCH GROUND WIRING.

THE "GROUND" COUNTERPOISE SHOULD HAVE AT LEAST 4 or 5 BARE COPPER WIRES LAID ON TOP OF THE GROUND OR BURIED WITH NO MORE THAN 6 INCHES OF DIRT. WHEN USED WITH A "CLEAR" FREQUENCY, A TRANSMIT POWER OF 35 WATTS OFTEN GIVES 20-60 MILES OF COVERAGE!

NOTE: THIS ANTENNA WILL OPERATE AT REDUCED EFFICIENCY WITH A SINGLE GROUND WIRE.

J. Cunningham Engineering  
1995 Stonewall, OK USA

THE DDDR "GALCOM"

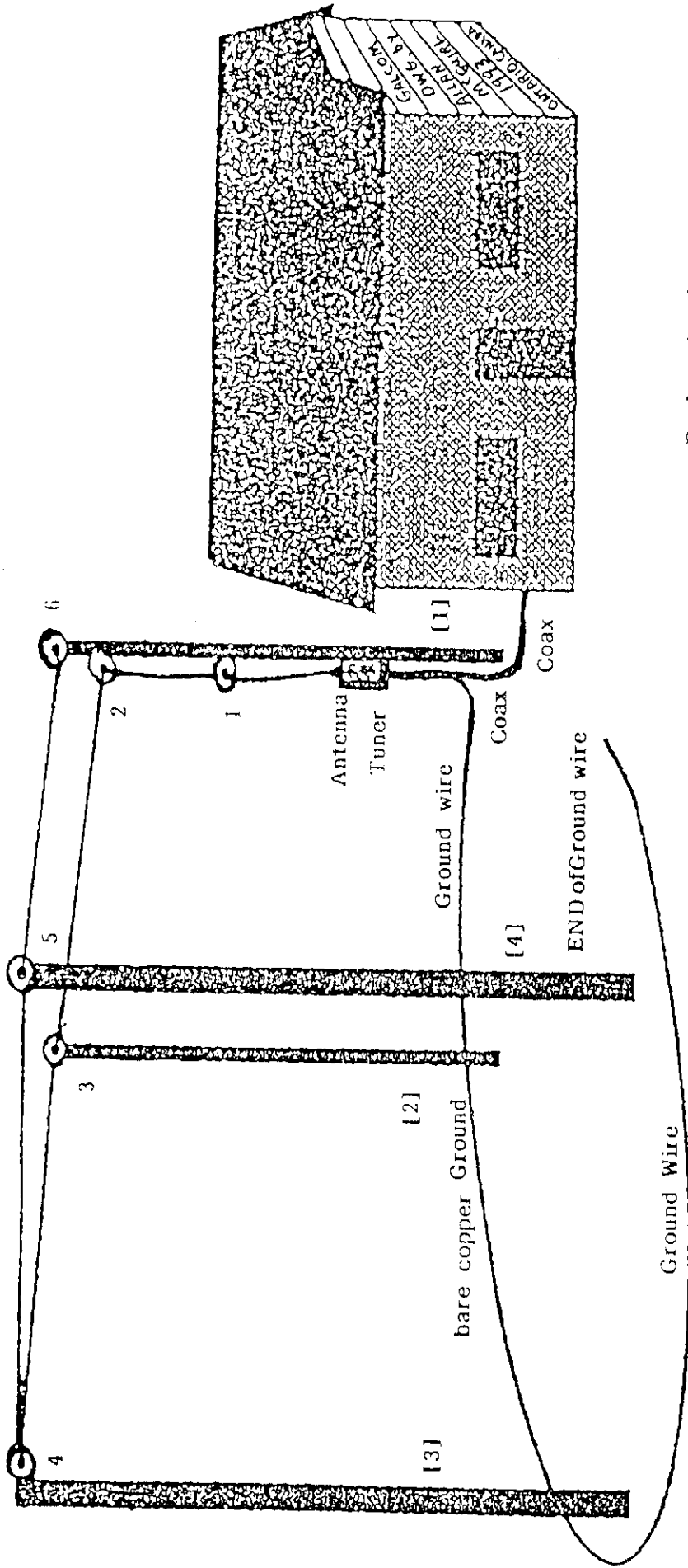

Engineering by:  
James R. Cunningham - USA 1993

THE DDDR ANTENNA

1. Use 4 poles (wood or metal) 10 feet high or no more than 20 feet high for the DDDR "Effect"
2. Use 6 INSULATORS of the Ceramic "Screw In" Type or "Dog Bone" Type
3. Use 1/4 or 1/2 Wavelength #18-#6 Gage bare copper wire for "GROUND" [Wire ends 1 ft. from #1 Pole!]
4. Use 1/4 or 1/2 Wavelength #18-#6 Gage INSULATED WIRE for TOP ANTENNA WIRE
5. TUNE WITH ANTENNA TUNER FOR MAXIMUM RADIATION

Southeastern

# TECHNICAL SERVICES

— BROADCAST

— RADIO

— TV

James R. Cunningham, Bdcst. Eng. [405-265-4496]

P.O. Box 8, Stonewall, OK 74871

October, 1993

## THE "GALCOM" WIRE ANTENNA

The "GALCOM" wire antenna (placed on poles) is a modification of the DDDR vertically polarized antenna FEATURED IN "The Radio Amateur's Handbook" of 1965. It is illustrated on PAGE 372. That drawing is copied below:

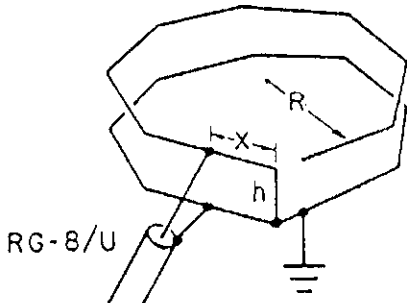

(B) The unusual DDDR vertically-polarized antenna. Length around top (open) wire or bottom (closed) wire, in feet, =  $252/f$  (Mc.) (E.g., 64.7 feet for 3.9 Mc.). Height  $h = 8.5/f$  (Mc.) (E.g., 2.2 feet at 3.9 Mc.) The feedpoint distance,  $x$ , is given approximately by  $x = 28/f$  (Mc.). (E.g., 7.2 feet at 3.9 Mc.)

### The DDDR Antenna

A new (and controversial) vertically-polarized antenna is the DDDR (directional-discontinuity ring radiator) shown in Fig. 14-27B. (See *Elec-*

*tronics*, January, 1963). If an excellent ground is available, the bottom wire would not be required, otherwise it should be laid on the ground or the roof or whatever flat plane the DDDR is placed over. The antenna shown is the version tried by WØMOX, which is simpler to construct than the original circular configuration. This is an antenna that merits further investigation by experimentally-inclined amateurs.

The Antenna is  $1/4$  wavelength long, placed in a circular or rectangular fashion, measures 36.6 ohms, Zero Reactance, and is tuned with a Standard "T" Network Tuner. Its VERTICAL RADIATION ANGLE IS 36 Degrees, with confirmed vertical polarization. The Antenna's SIGNAL STRENGTH is 28 MV/M per Amp. which corresponds to 145 MV/M per 1000 Watts Input Power.

The 36.6 Watts from James R. Cunningham's Tube Type Transmitter provides an antenna current of 1 Amp. into the Antenna shown above. The expected radiation is 28 MV/M at 1 mile distance from the Antenna Site.

ANTENNA RADIATION MAY BE INCREASED BY ADDING 120 -  $1/4$  wavelength GROUND RADIALS below the center of the antenna, extending towards all points of the Compass. Theoretical Signal strength INCREASES TO: 35.53 MV/M per Antenna Amp. or 186.2 MV/M at 1 mile with 1000 watts Antenna Input if the superior ground system is used.

JAMES R. CUNNINGHAM

*James R. Cunningham*  
Oct. 1, 1993

# A.M. RADIO TRANSMITTER KIT

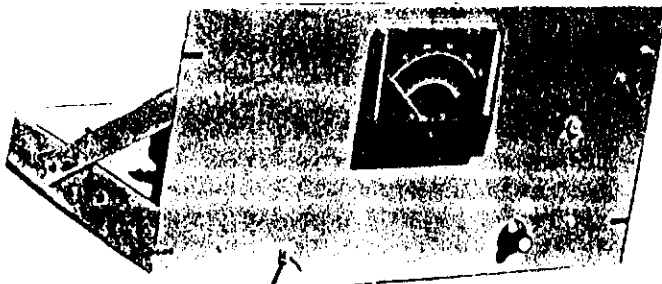

**Transmitter**  
CM Model 30-50

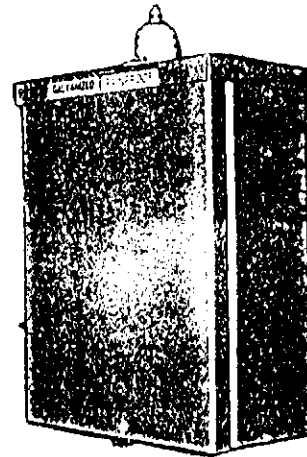

**Antenna Tuner**

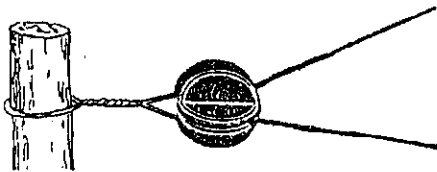

**Insulators**

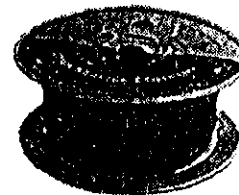

**Wire**

WITH INSTRUCTION BOOKS

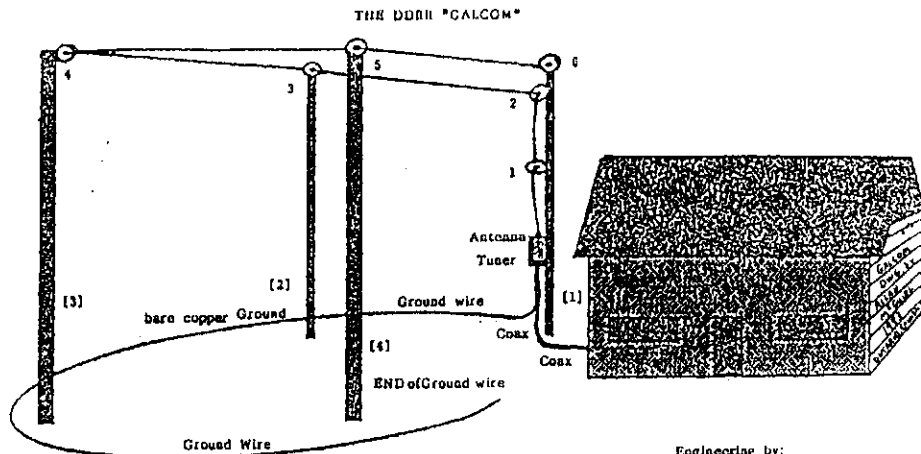

Engineering by:  
James R. Cunningham - USA 1993

## THE DDRR ANTENNA

1. Use 4 poles (wood or metal) 10 feet high or no more than 20 feet high for the DDRR "Effect"
2. Use 6 INSULATORS of the Ceramic "Screw In" Type or "Dog Bone" Type
3. Use 1/4 or 1/2 Wavelength #18-#8 Gage bare copper wire for "GROUND" (Wire ends 1 ft. from #1 Pole!)
4. Use 1/4 or 1/2 Wavelength #18-#8 Gage INSULATED WIRE for TOP ANTENNA WIRE
5. TUNE WITH ANTENNA TUNER FOR MAXIMUM RADIATION

EXAMPLE

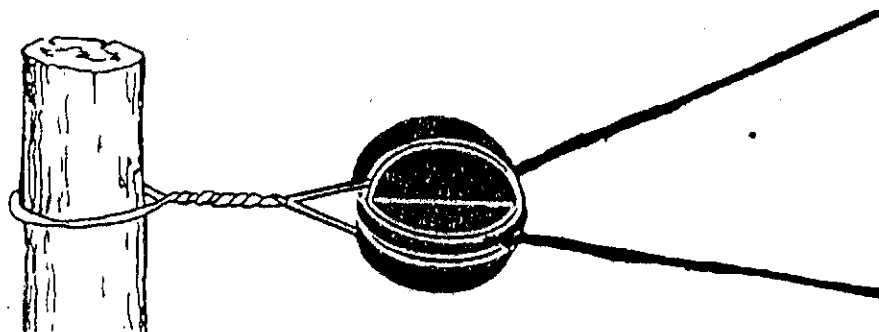

#### CORNER INSULATOR USE

If your Antenna is constructed in a Circle, Triangle, or Rectangular mode, the "Egg" Style Insulators may be used as demonstrated here. It is important to keep the "Hot" Wire away from all metal and wood objects, especially if your Antenna Wire is bare. Insulated wire will do better, but it also must be kept away from objects for best performance.

SINGLE POLE ANTENNA  
for  
LOW POWER RADIO STATION USE

USE: Powers up to 50 and 100 Watts  
Low Powered Radio Systems.

TESTED 1992 - J.R. CUNNINGHAM  
Test Engineer United States Of America

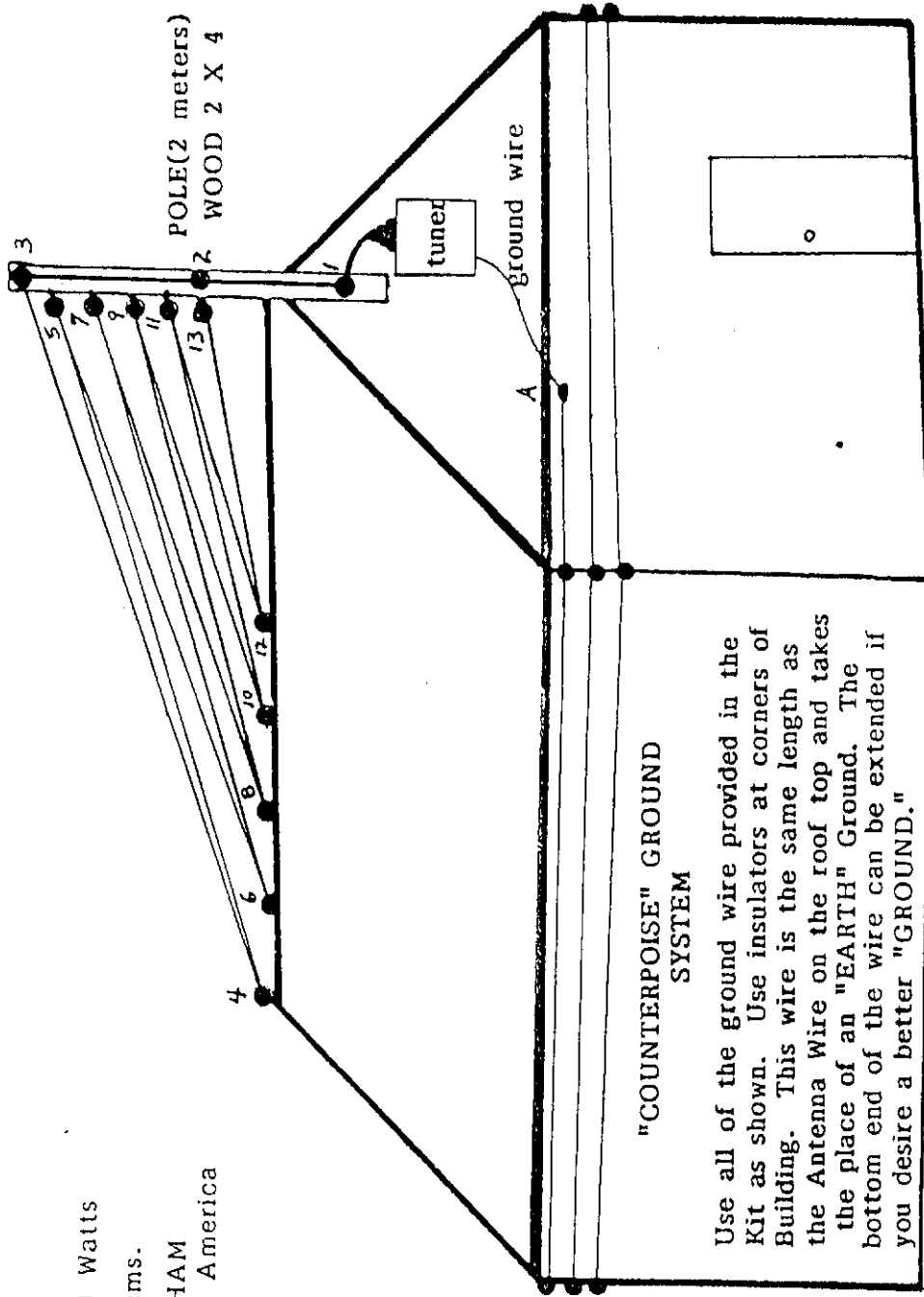

"COUNTERPOISE" GROUND  
SYSTEM

Use all of the ground wire provided in the Kit as shown. Use insulators at corners of Building. This wire is the same length as the Antenna Wire on the roof top and takes the place of an "EARTH" Ground. The bottom end of the wire can be extended if you desire a better "GROUND."

INSTRUCTIONS:

Use all of the wire in your antenna Kit as shown. The "Insulated" wire should go on top as shown. The distance between insulators 1,2, and 3 should be as is convenient. Distance between 5, 7, 9, 11, and 13 should be between 10 and 15 CM. Distance between 4, 6, 8, 10, and 12 is whatever is convenient. "GROUND RADIALS" [COUNTERPOISE] begins at point "A" and continues around building on INSULATORS.

## USING THE INSULATORS

You can use the three Poles as shown. These are made of WOOD. The INSULATORS are SCREWED INTO THE WOOD POLES as shown. NOTICE that the first insulator is just above the top of the Tuning Box. This vertical wire is part of the top antenna wire and must be kept from touching the Pole. Mount the Tuning Box to the First Pole as shown here.

Separate the Three Poles by about 46 feet each, so that you will have sufficient Vertical "LEAD IN" wire to reach the top of the Tuning Box, where it is connected to the Porcelain Insulator Stud.

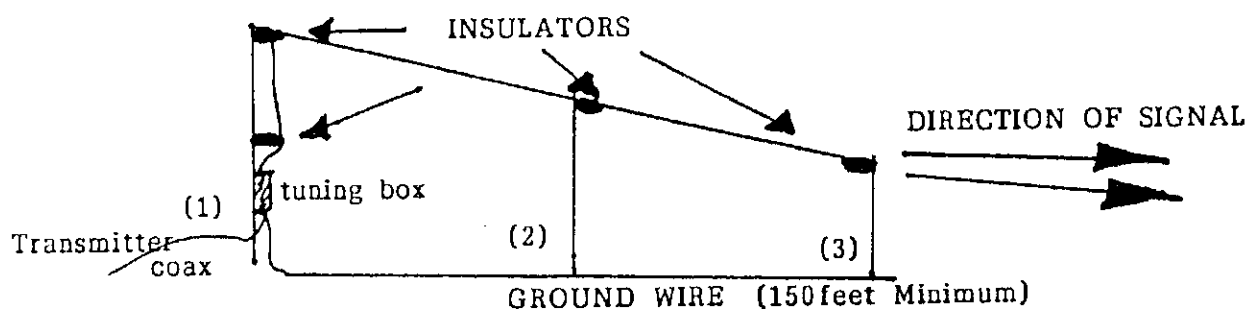

USE ALL OF THE WIRE IN THE KIT FOR THE GROUND. YOU CAN ADD MORE IF YOU WISH TO IMPROVE THE SIGNAL. ALL OF THE GROUND WIRE GOES TO THE RIGHT SIDE OF THE DRAWING, SO THAT ALL OF THE SIGNAL WILL GO IN THAT DIRECTION!

## POLES

POLES ARE MADE OF WOOD.  
The First Pole is 15 feet high.  
The next Pole is 10 feet high.  
The last Pole is 6 feet high.

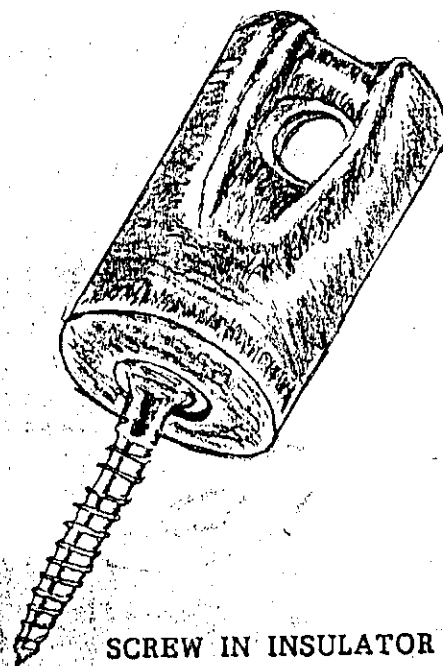

HOW TO TIE OFF ENDS  
OF ANTENNA WIRES

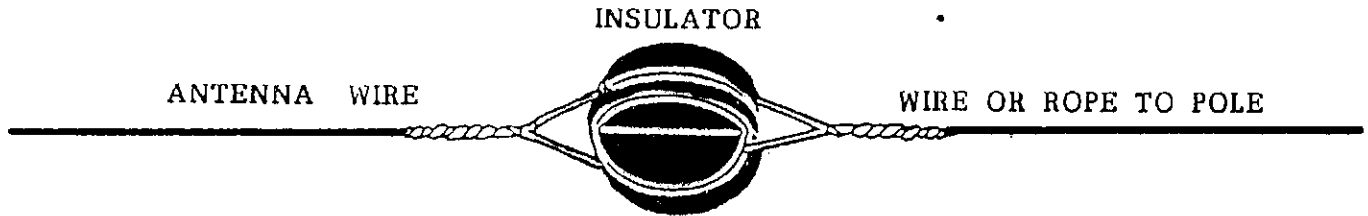

IF YOUR ANTENNA WIRE COMES TO AN END  
BETWEEN TWO POLES, YOU MAY USE AN INSULATOR  
AS SHOWN TO "TIE OFF" THE WIRE.



## GETTING DIRECTIONAL WITH WIRE ANTENNAS

The long wire antenna system can be easily made to perform in a single direction. There are just a few simple rules to obey and you will have the results you need.

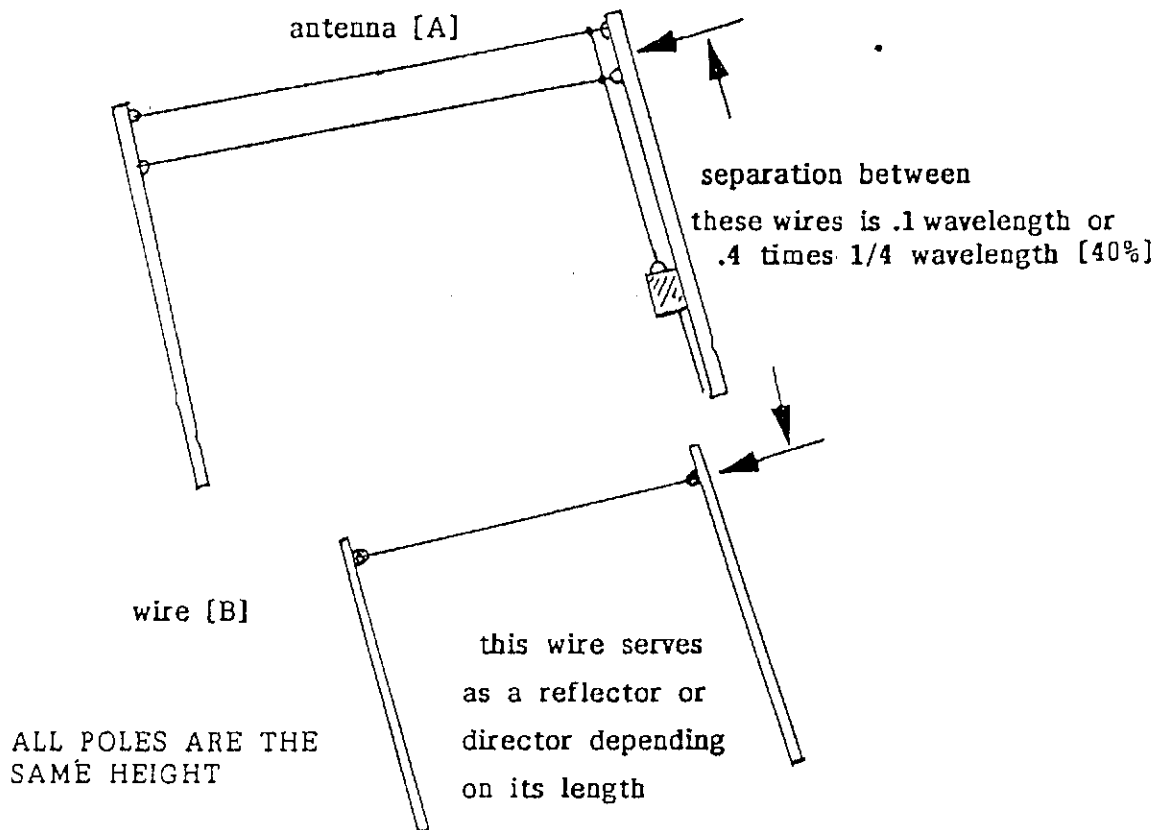

Wire "B" will pull the signal toward itself or reflect the signal away from itself depending on its length. As Reflector it pushes the signal away from itself. As Director, it pulls the signal toward itself.

Rule for Director: make this wire 4 percent SHORTER than the antenna wire.

Rule for Reflector: make this wire 5 percent LONGER than the antenna wire.

Making the Antenna directional will increase the Antenna Gain. This acts as if you have multiplied the transmitter power, but your signal will mostly be in one direction only. Use of both reflector and director acts as if you have increased transmitter power 6 times! Use of 1 added element, 3 times the power!

EXAMPLES OF WIRE ANTENNAS  
and ASSOCIATED RADIATION PATTERNS

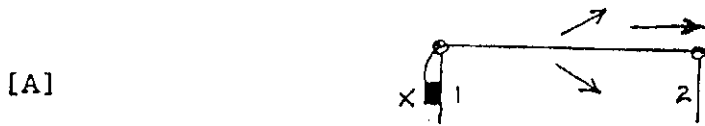

ALL WIRES  
ARE INSULATED  
FROM POLES AND  
TUNED AT [X].

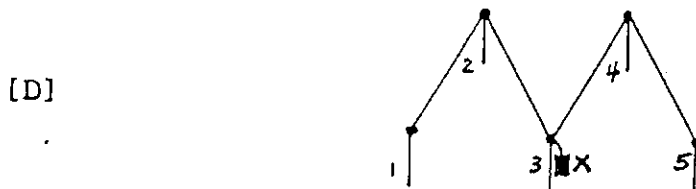
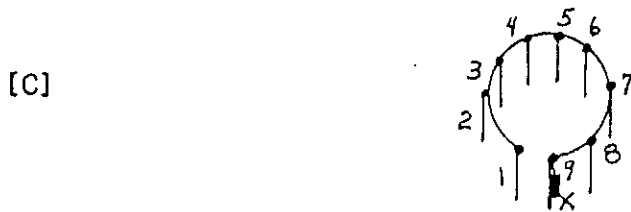

EXAMPLES

A. Example [A] uses a wire stretched between poles (1) and (2). Point (X) is the tuning device. A Standard 1/4 wavelength wire will tend to radiate in a direction AWAY FROM THE TUNING DEVICE AND TOWARD TOP AND BOTTOM OF THE DRAWING.

B. This antenna is stretched between (3) poles and tuned at point (X). This wire tends to send out its signal equally well IN ALL DIRECTIONS.

C. This wire antenna is made CIRCULAR using 9 poles and tuned at point (X). Its radiation pattern is also IN ALL DIRECTIONS (CIRCULAR).

D. Using a 1/4 wavelength wire on each side of point (X), this "M" shaped antenna using 5 poles also radiates very well in ALL DIRECTIONS.

## THE IMPORTANCE OF GROUNDING FOR AM RADIO

In the case of AM Radio, the "antenna" consists of TWO PARTS. (1) The TOWER or ANTENNA WIRE ELEMENT SUSPENDED ON POLES AND INSULATORS and (2) THE EARTH ITSELF.

In order to make the earth act as the second half of an AM ANTENNA, you must have a number of ground wires going in all directions. It has been found by actual experience that in very dry areas, 120 wires at least 1/4 wavelength long are needed or the signal will not leave the tower or wire for its desired receiving points.

GROUND CONDUCTIVITY describes the ability of the earth to act as the other half of your antenna. In rare cases, where there is much surface water, or water less than 20 feet below the surface, there is no need for many GROUND RADIALS (as the ground wires are called). The earth itself carries the signal out in what is called A GROUND WAVE. This ground wave is very helpful in order to reduce "fading" and weak signals. The ground wave can reach out about 100 miles, and in some cases 150 miles from the transmitter site.

IT IS IMPORTANT TO SET UP A "GROUND WAVE" from an AM Station. One can not depend completely upon one or two ground wires, even where the earth is full of ground water because such a few number of wires may develop problems, or for some reason fail to operate correctly, so A LARGE NUMBER OF GROUND RADIALS IS RECOMMENDED for AM Stations - AS MANY AS POSSIBLE - UP TO 120 QUARTER WAVELENGTH RADIALS going out to all points of the compass!

ONE OF THE ANTENNAS WE USE IN OUR LOW POWER AM INSTALLATIONS IS THE "DDRR" TYPE used by GALCOM and developed by James R. Cunningham especially for this purpose. This Antenna uses only 1 GROUND RADIAL under NORMAL CONDITIONS, BUT IN SOME CASES IT MAY REQUIRE MANY, MANY MORE RADIALS - especially where the earth is DRY, SANDY OR ROCKY!! If you have a question about the effectiveness of the SIGNAL, contact us for consultations before investing in a system or acquiring the station LICENSE!

## SHORT WAVE RADIO

The importance of GROUNDING decreases for short wave, especially at frequencies above 3-5 MHZ. Short wave at these lower frequencies also needs good grounding, but it is not nearly as critical as the AM Frequencies below 1 MHZ! Many AM Broadcasters chose a LOWER FREQUENCY under the belief that it will reach out farther, ONLY TO SUFFER FAILURE BECAUSE THEY CAN NOT AFFORD TREMENDOUS EXPENSES ASSOCIATED WITH BUILDING AN AM ANTENNA SYSTEM BELOW 1 MHZ. If you select a frequency BELOW 1 MHZ, BEWARE! YOUR SIGNAL WILL NOT DO WELL UNLESS YOU SPEND OVER A THOUSAND DOLLARS FOR A SIMPLE SYSTEM AND MANY THOUSANDS OF DOLLARS FOR THE BEST!

## HOW TO INSTALL YOUR ANTENNA

1. Assemble your new antenna on the ground in accordance with separate assembly instructions supplied with it.
2. On the ground, clamp antenna to mast, pull enough transmission line to connect to antenna.
3. Install selected mounting bracket.
4. If you are going to use guy wire installation instead of a mounting bracket:
  - install guy anchor bolts
  - estimate length of guy wire and cut
  - attach to mast using guy ring
5. Mount the extra "Warning Label" supplied in the hardware bag on the antenna mast at eye level after installation has been completed.

## ANTENNA REMOVAL

Removal of the antenna should be exactly the reverse of the installation instructions. Please, for your own safety, follow the instructions for installing the antenna starting with the last step first. That's the only safe way to remove an antenna.

## LIGHTNING PROTECTION

To protect your house and your TV (FM, CB, etc....) installation, the mast of your antenna system must be properly grounded. Drive a 4' - 8' ground rod as close as possible to the antenna supporting structure or antenna base. Then connect a #8 (or larger) copper or aluminum wire between the base of the antenna and the ground rod. Also, an antenna discharge unit (sometimes referred to as a lightning arrester) should be connected to the antenna lead-in at the place where it enters the home. (Follow the instructions provided with the static discharge unit.)

## ANTENNA DISCHARGE UNIT

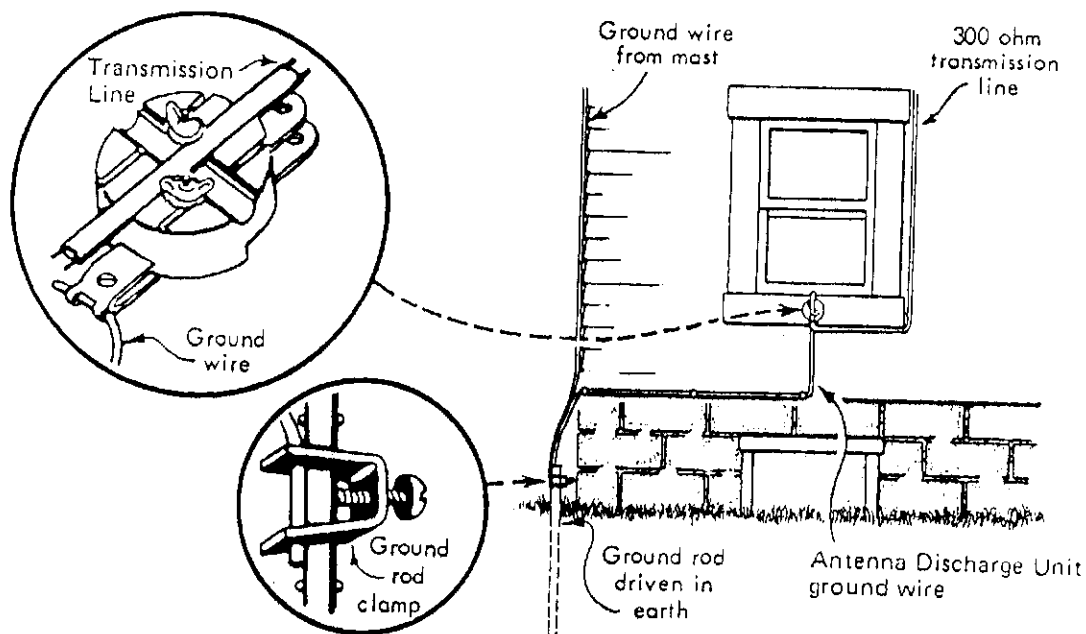

## A SINGLE SIDED UNIPOLE

metal bar (connect direct to Tower)

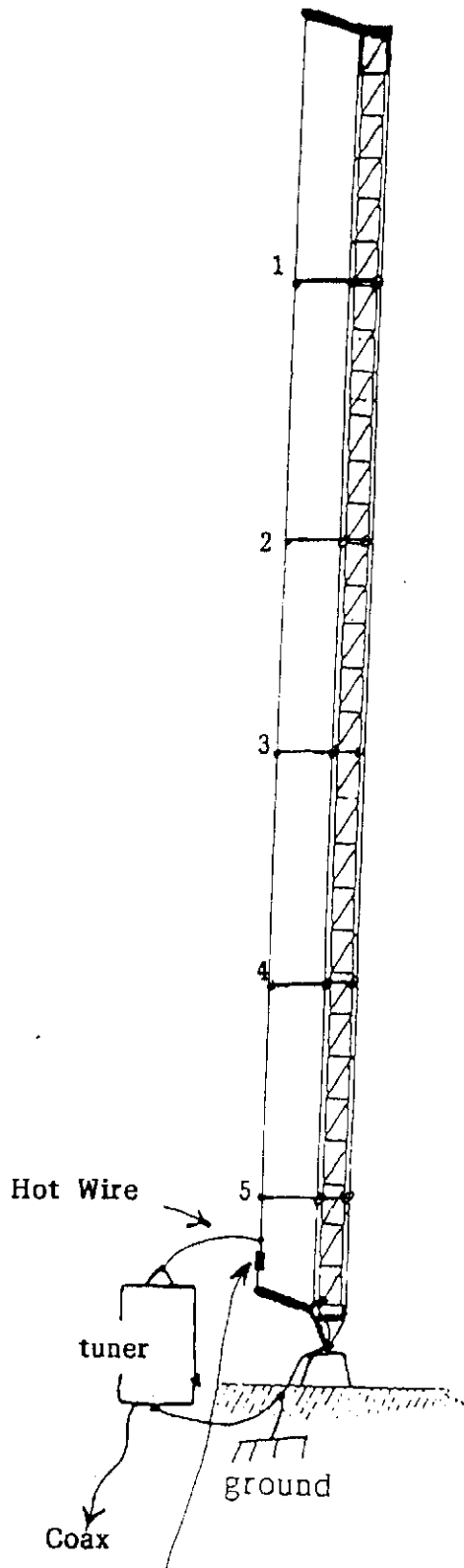

Insulator  
Make it from PVC Pipe  
drilled on each end to hold wires.

### PVC PIPE

1/2 to 1 inch PVC Pipe will work for holding the vertical wire. Drill through the ends and use wire to secure the Vertical Wire to the PVC Pipe ends. This can be done to hold the PVC Pipe to the Tower as well.

### TUNING

Tune the Wire going up the Tower and the whole Tower will radiate The Signal.

### NOTES:

1,2,3,4, and 5 are PVC Pipe Insulators (connect them through the Tower Legs and use tape or stiff wire to hold in place) These will stand out away from Tower 1 foot or more - not critical.

### TUNER BOX

Mount Tuner Box direct to Metal Frame of the Tower Legs. Be sure the entire Tower is grounded well.

## FOLDED UNIPOLE TUNING

THERE ARE BASICALLY TWO METHODS OF TUNING UNIPOLES:

1. Tune for 50 ohms resistance with positive Reactance
2. Tune for ZERO REACTANCE with a higher input Resistance in the range of 110 - 125 Ohms.

### METHOD NUMBER ONE:

A. The tuning skirt is shorted to the Tower at 1/20th wavelength from its bottom. If the Tower is a 1/4 wavelength Tower, this would amount to 1/5th its height. This will give an Antenna Resistance of 50 ohms with between 200 and 350 ohms + Reactance (inductive) at the Feedpoint.

B. Tune out the + Reactance with a variable or fixed capacitor. Its value will be between 350 and 2500 PicoFarads, depending on the frequency of operation within the Broadcast Band.

### METHOD NUMBER TWO

A. Adjust the shorting bar or ring UPWARD to a point where ZERO REACTANCE shows on an Impedance Bridge at the Feedpoint. The Antenna RESISTANCE will fall somewhere between 110 - 125 Ohms. This Resistance is matched to the 50 Ohm Feedline with a Standard AM ANTENNA TUNER.

B. Antenna height should be above 75 Degrees (.2 Wavelengths) for best results if this Method is used. Shorter Towers may work better with Method Number One.

GUYING FOR 50 Foot Towers  
ROHN 25G

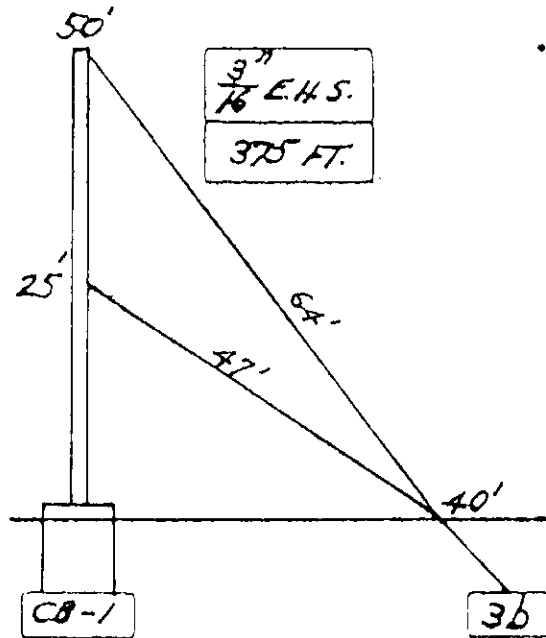

1. Tower Height: 50 Feet
2. Total Guy Cable Required: 375 Feet per tower
3. Anchors are located 40 Feet from Tower Base as shown

See the following Pages for Base and Anchor Details

UNIPOLE WIRE SUPPORT

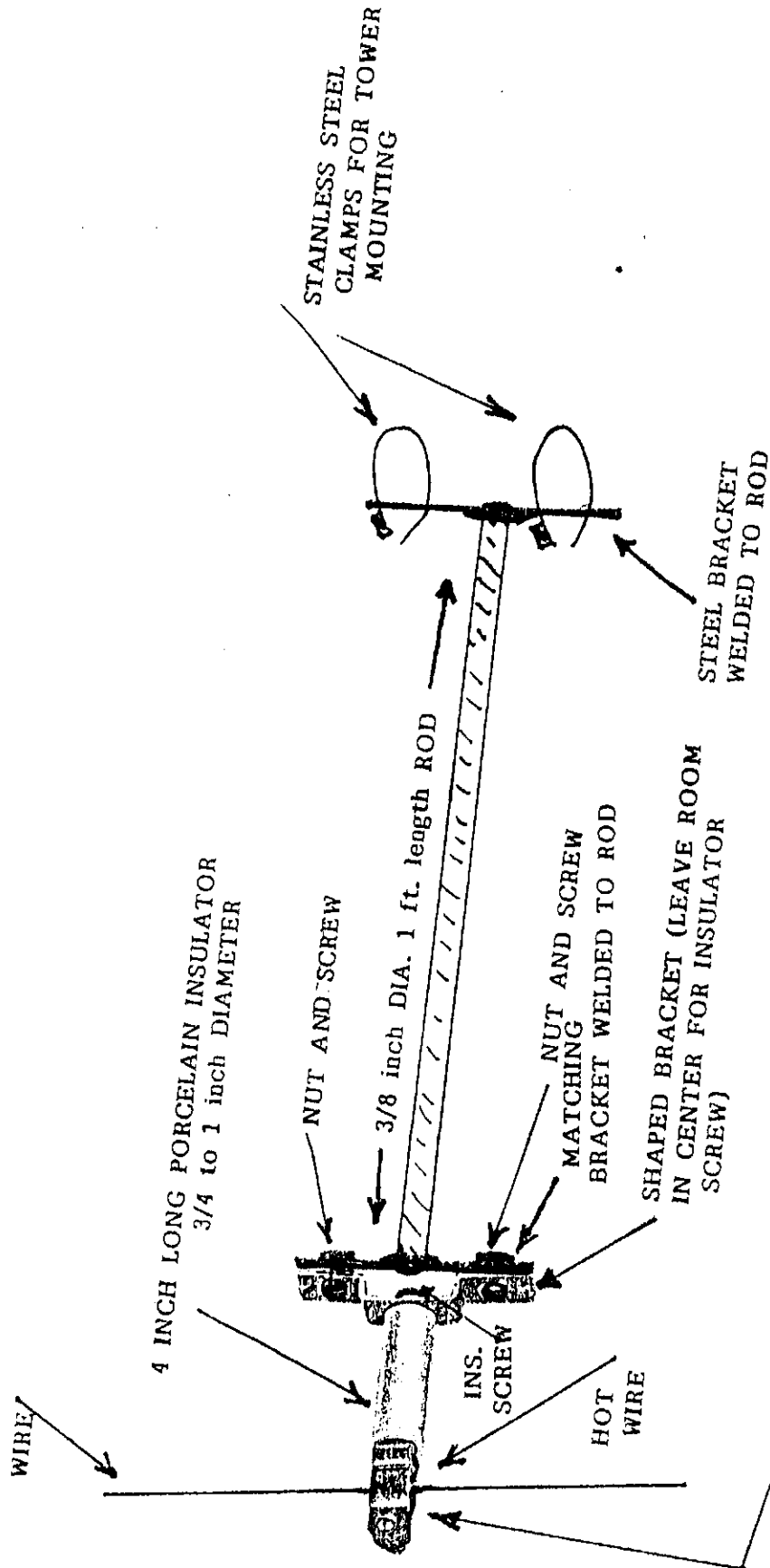

WIRE BRACKET MAY BE IMPROVISED OR MADE FROM COMMERCIALY AVAILABLE CLAMPS.



# FOLDED UNIPOLE TOWER SYSTEM

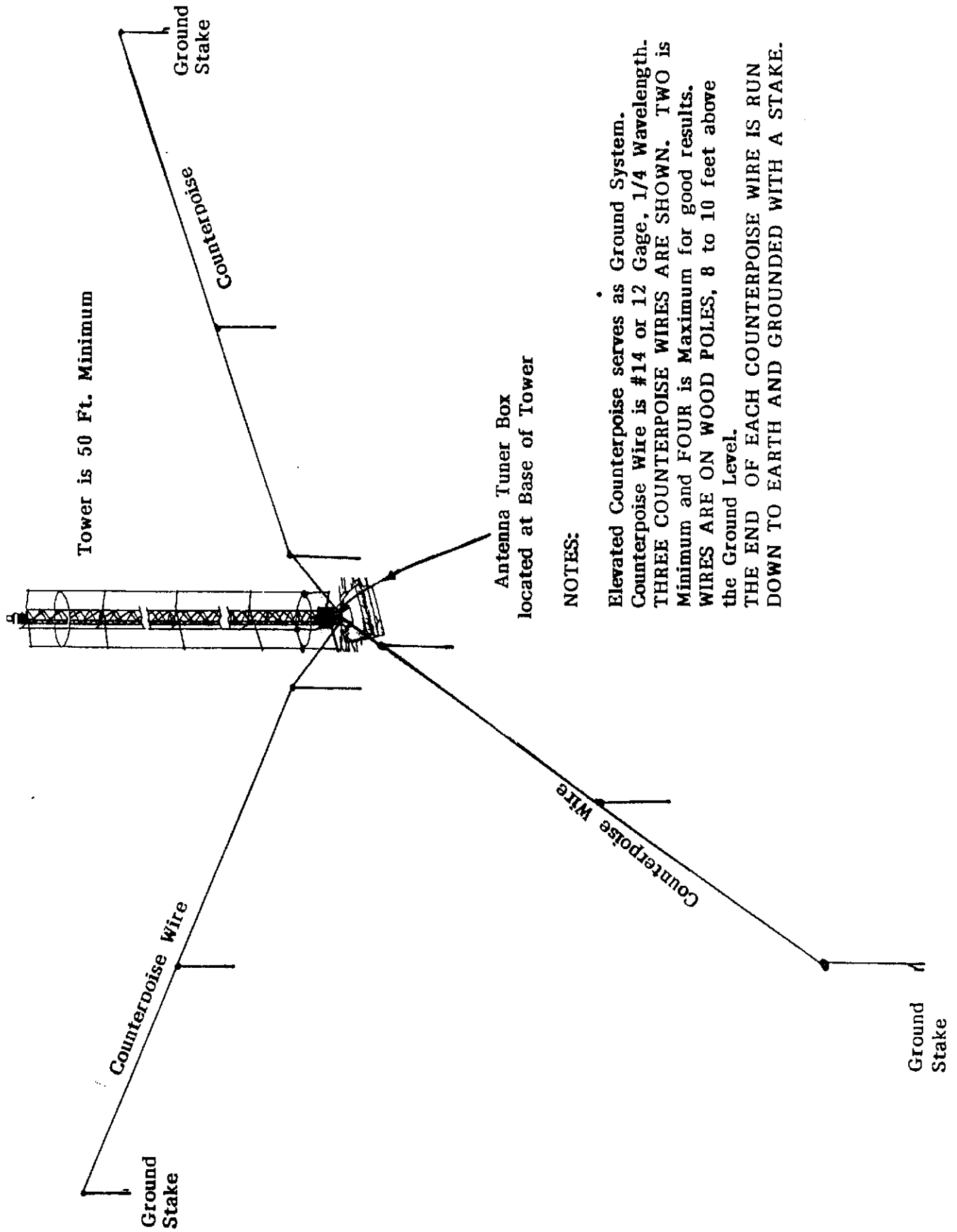

## NOTES:

Elevated Counterpoise serves as Ground System.  
Counterpoise Wire is #14 or 12 Gage, 1/4 Wavelength.  
THREE COUNTERPOISE WIRES ARE SHOWN. TWO is Minimum and FOUR is Maximum for good results.  
WIRES ARE ON WOOD POLES, 8 to 10 feet above the Ground Level.  
THE END OF EACH COUNTERPOISE WIRE IS RUN DOWN TO EARTH AND GROUNDED WITH A STAKE.

PROPOSED "FOLDED UNIPOLE"  
WIRE ANTENNA

DESCRIPTION

1. Two parallel #10Gage Wires go up the side of the Bldg. mounted on 20 inch standoff Insulators (locally made).
2. Total length of both Wires (added together) must be at least 150 Feet.
3. Point "X" is where both Wires are connected together as determined by Engineer.
4. Transmitter and Tuning Box are located inside bottom of Structure.
5. RF Feedpoint goes through wall to Tuning Box.
6. Wire "B" is connected to Ground System at Base of Tower. RF Feedpoint from interior of Bldg. "A"

THE FOLDED UNIPOLE

Its high efficiency Design may be used with metal towers or any supporting structure as shown here.

This Design gives superior results in areas where the height of structure is limited and where there may not be enough room for a large number of ground Radials.

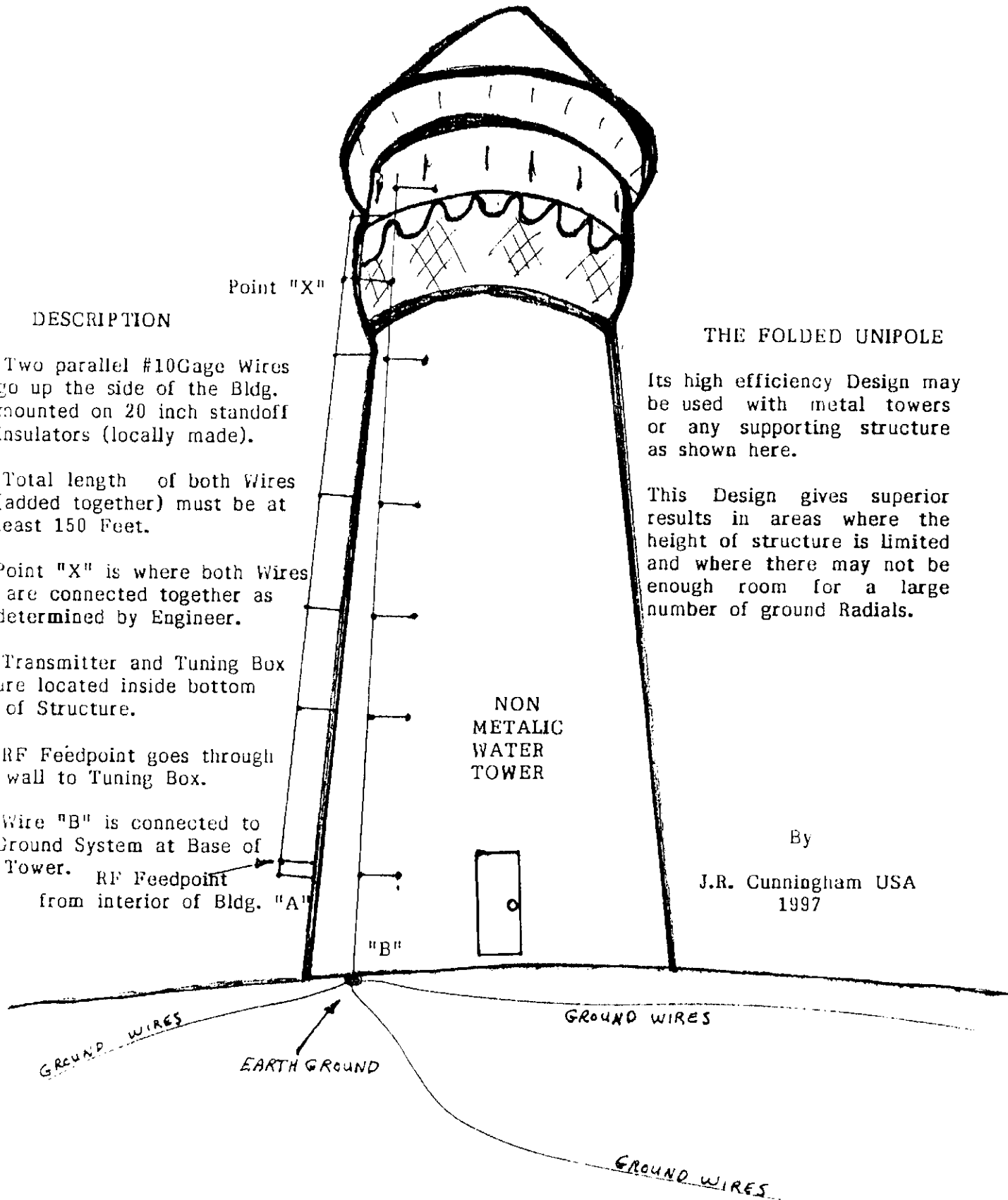

By

J.R. Cunningham USA  
1997

RADIO MISSIONARY FOLDED UNIPOLE

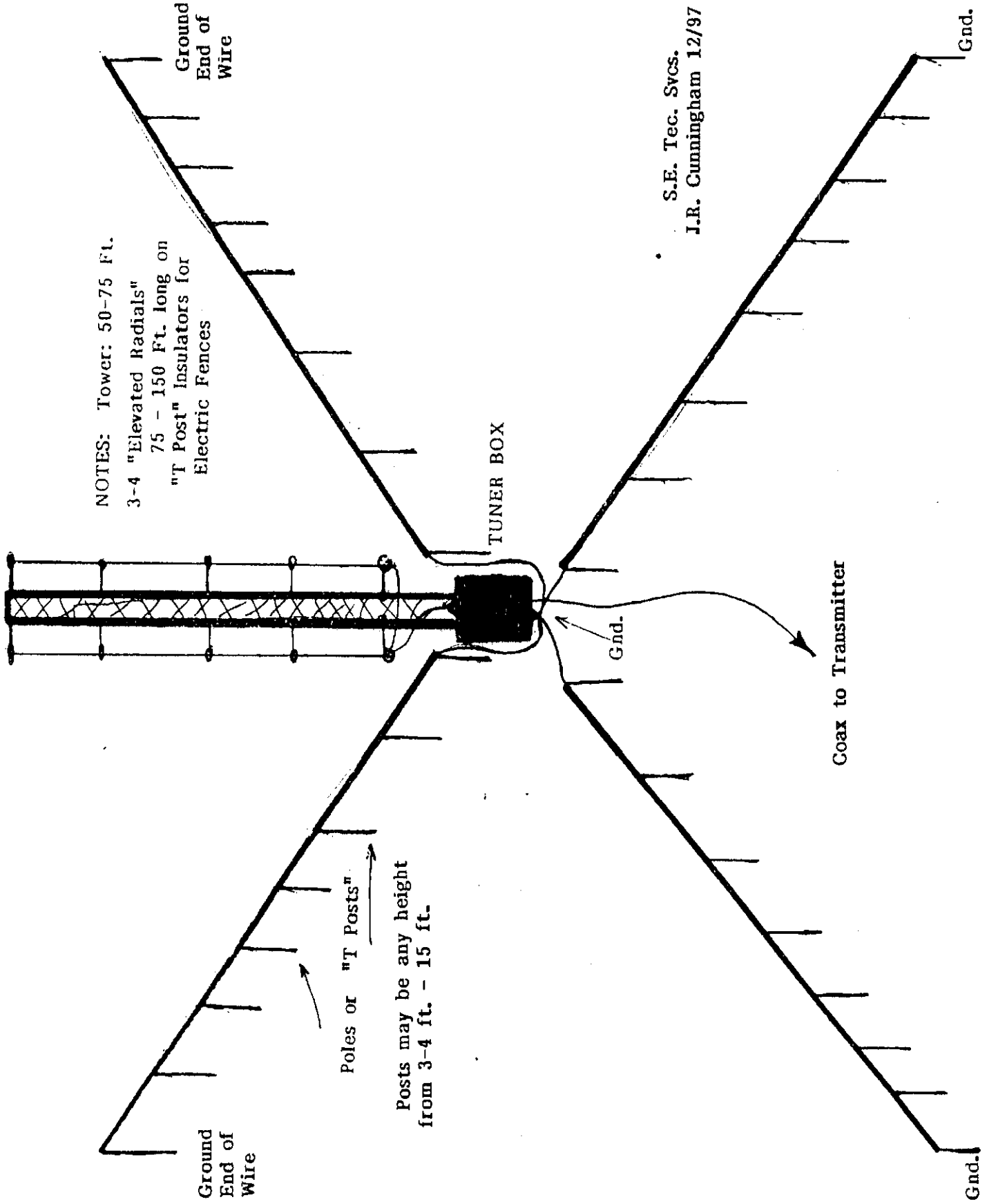

NOTES: Tower: 50-75 Ft.  
3-4 "Elevated Radials"  
75 - 150 Ft. long on  
"T Post" Insulators for  
Electric Fences

Poles or "T Posts"  
Posts may be any height  
from 3-4 ft. - 15 ft.

S.E. Tec. Svcs.  
J.R. Cunningham 12/97

Gnd.

Gnd.

Coax to Transmitter

Gnd.

TUNER BOX

Ground  
End of  
Wire

Ground  
End of  
Wire

FCC APPROVED SIX RADIAL  
GROUND SYSTEM ANTENNA

1. The Tower is in the center (looking down from above) and the six lines going out from the center are the ground radials. This is a true "COUNTERPOISE" and is supported at a height of about 5 to 10 feet above ground level using poles.

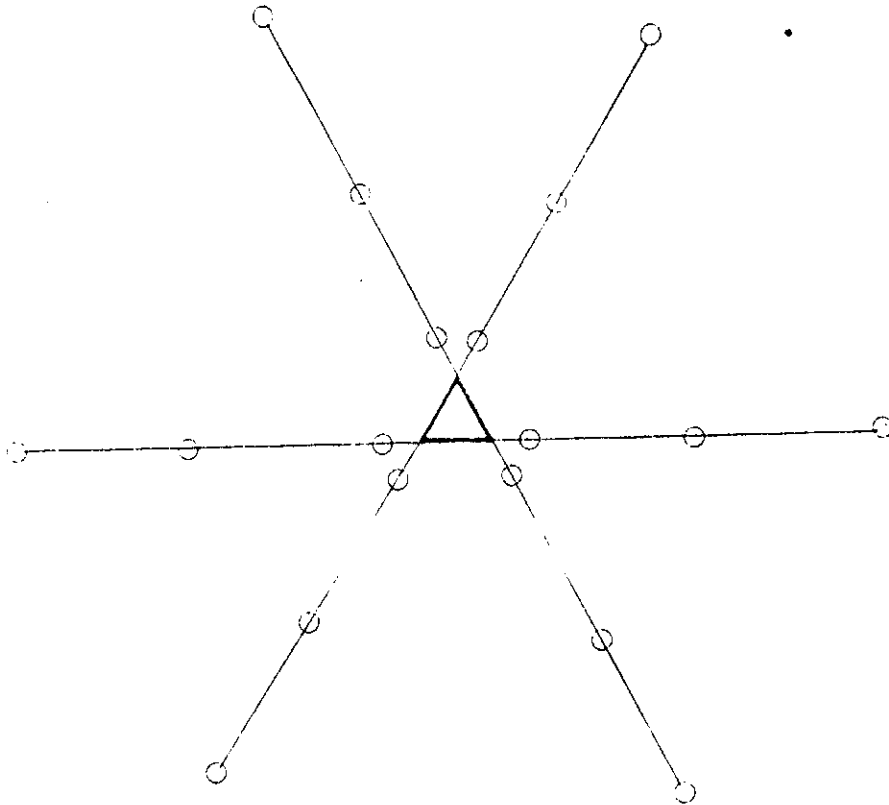

2. The poles are represented by the 18 small circles in the diagram. These poles are insulated from the wire radials which they support and may be of metal or wood. The tower may be a series fed tower or a folded unipole. The folded unipole is highly recommended. This ground radial system gives the theoretical radiation characteristics as required by the FCC for A.M. Radio Antenna Systems.

3. When the Tower is SERIES FED, the ground radials are isolated from the base of the tower. When a FOLDED UNIPOLE is used, the radials connect to the bottom of the tower and the tower is fed at the usual RF Feedpoint coming from the tuning skirt.

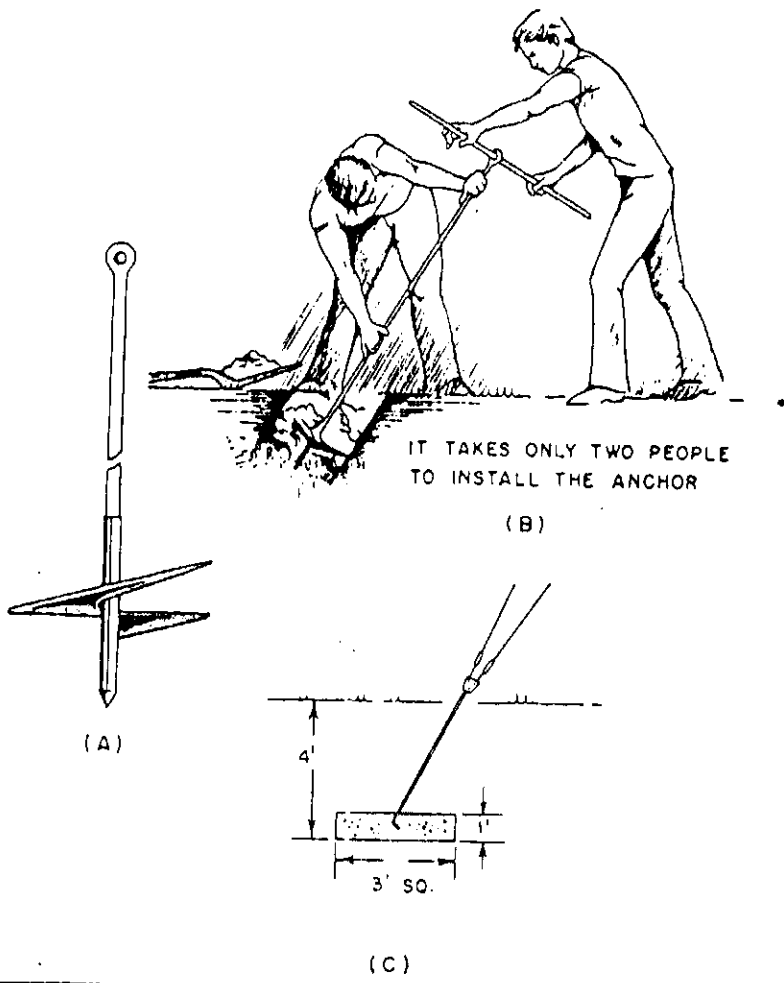

---

Two standard types of guy anchors. The earth screw shown at A is easy to install and widely available, but may not be suitable for use in certain soils. The concrete anchor is more difficult to install properly, but it is suitable for use with a wide variety of soil conditions and will satisfy most building code requirements.

## Mounting a 50 foot Mast/Tower

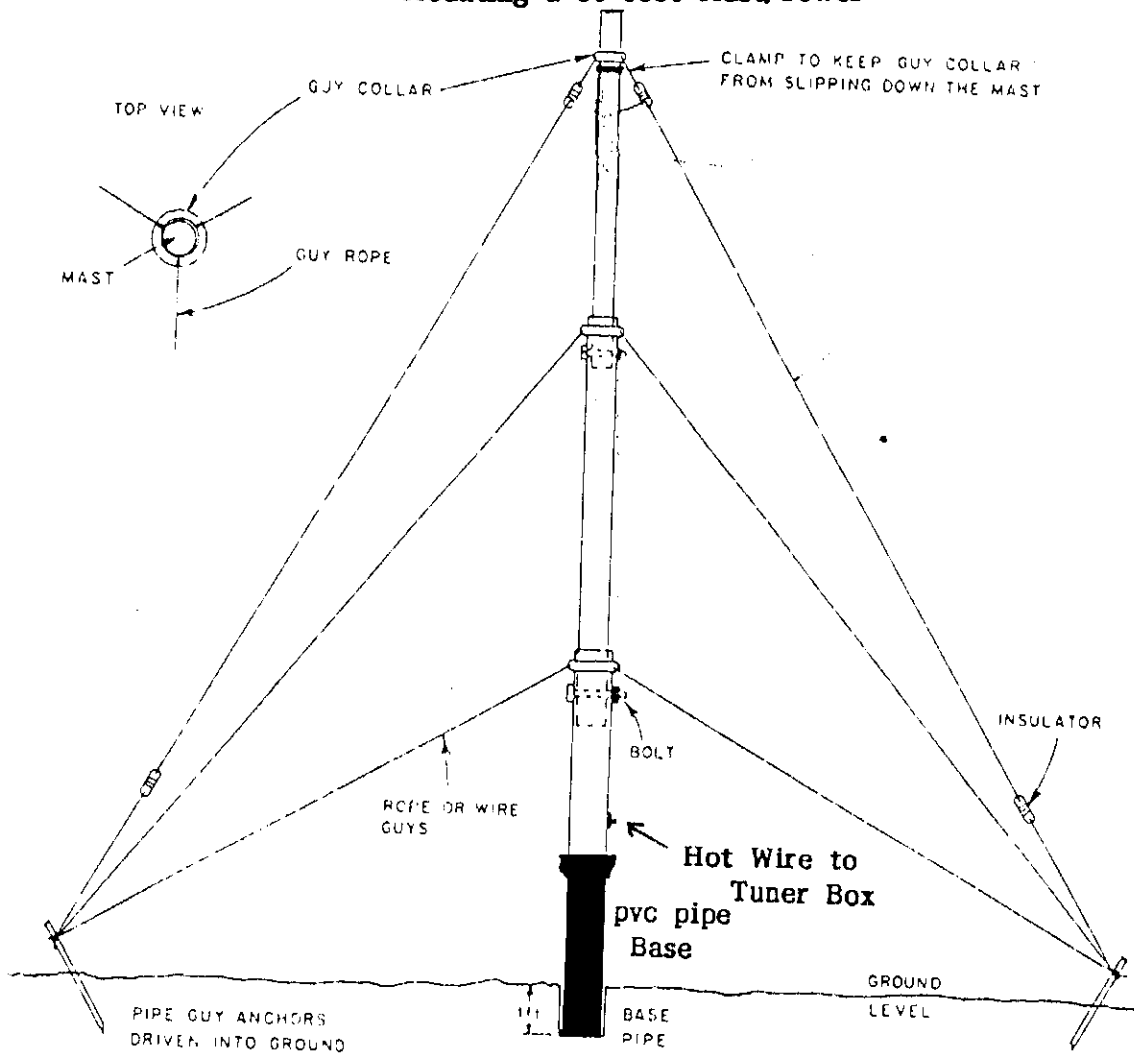

The mast may be made of steel pipe or aluminum tubing  
Use Plastic rope if you do not want to use insulators as shown.

UNIPOLE  
TOWER OR MAST SYSTEM

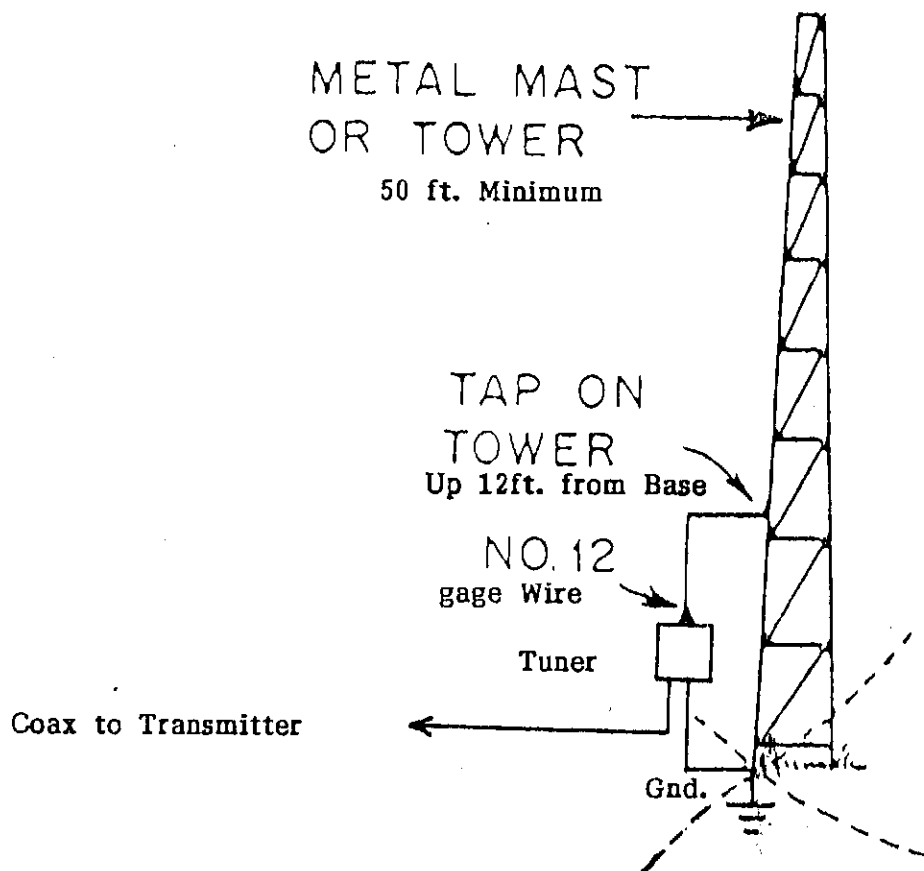

This Page illustrates how to use a metal mast or tower as a Folded Unipole to increase efficiency and to minimize the needed Height of the Antenna.

This will operate into the KW range in Power, especially if there is a good ground. Without a full ground system, this method will develop Harmonics if over 500 Watts of Power is used.

AM RADIO STATION GROUND SYSTEMS

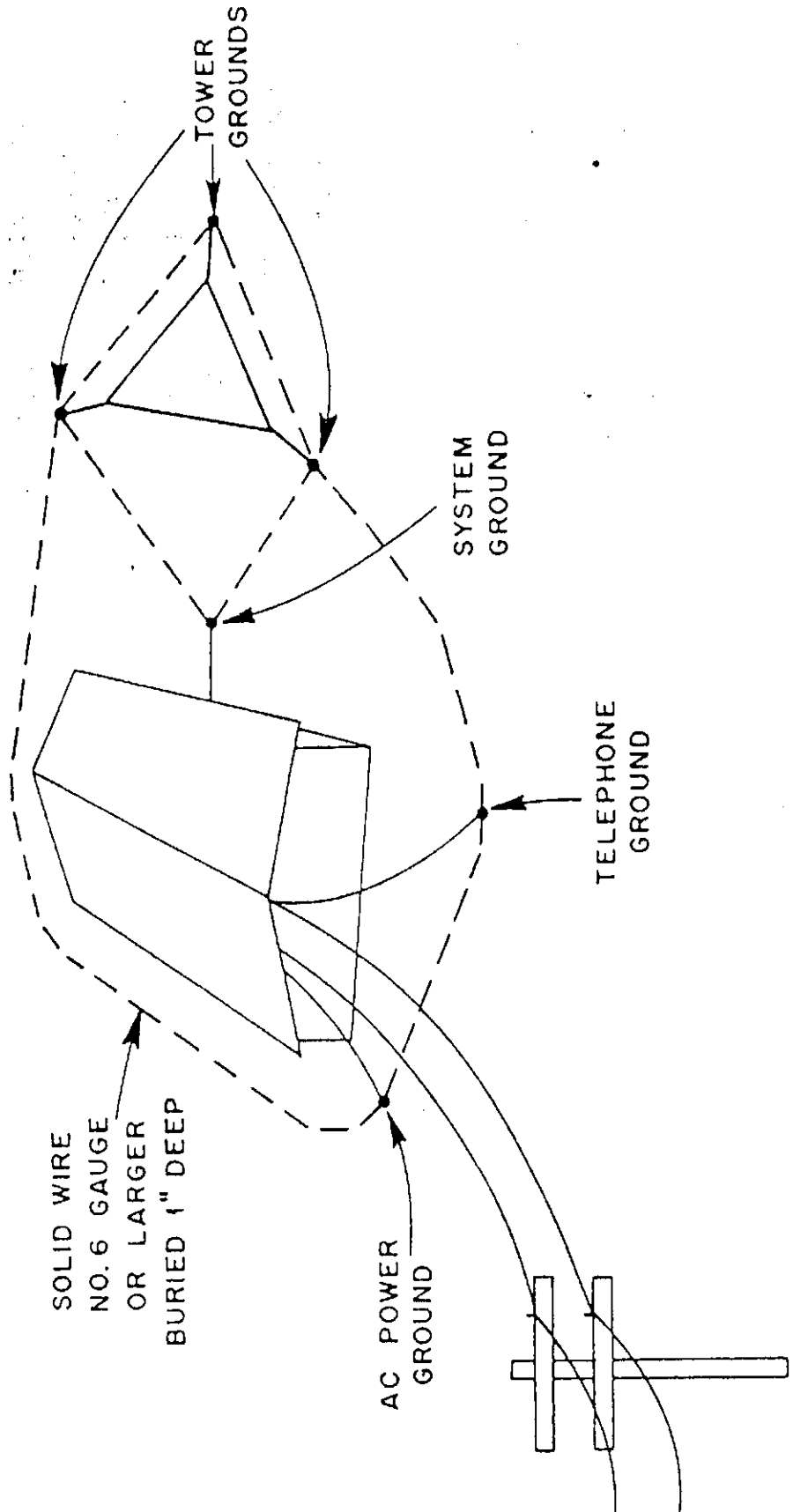



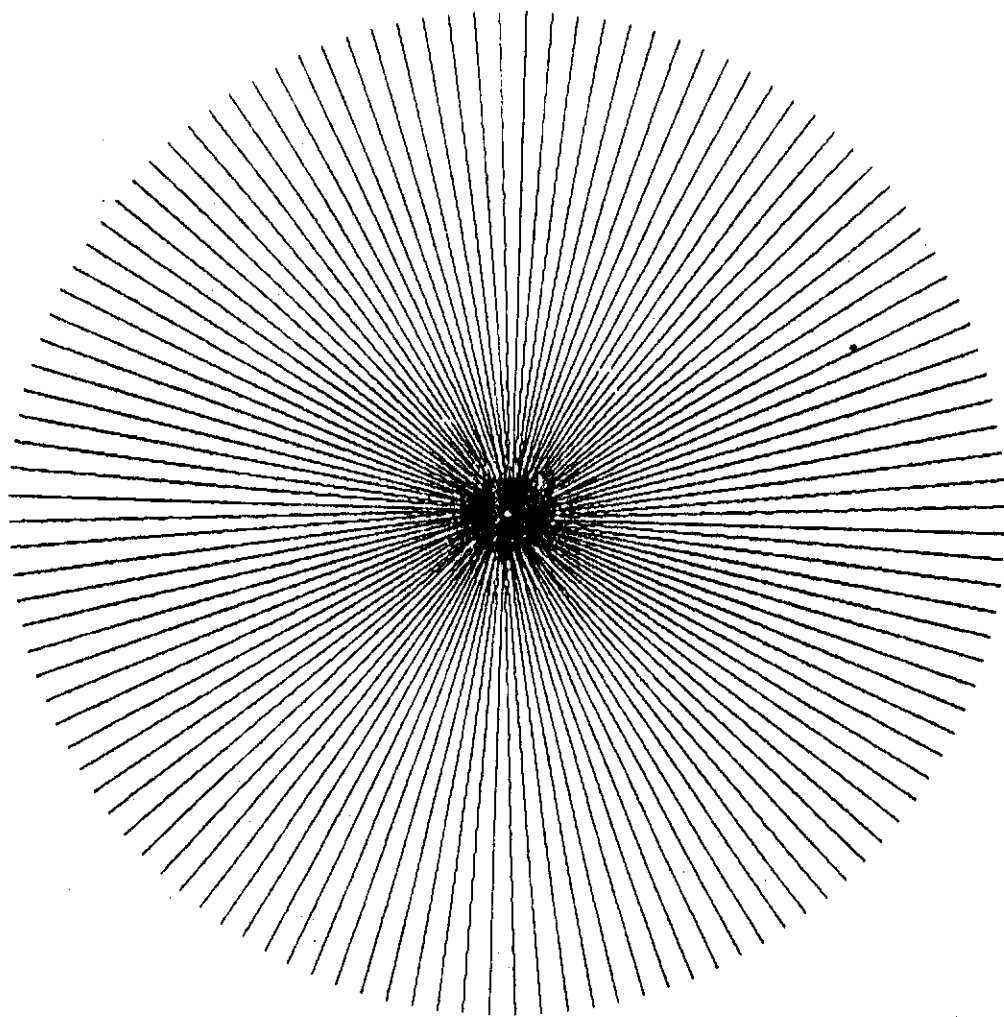

**120 Quarter Wave Length Copper**  
**FIGURE 1 NORMAL GROUND SYSTEM**

The dark area in the center is the **GROUND SCREEN** which is made from a 12 ft. by 12 ft. copper mesh screen obtainable from professional Antenna sales Companies or antenna installers.

All connections are "copper to copper" and each joint is "silver soldered" for a long lasting weather resistant splice. All Radials tie into the square Ground Screen and a wide copper strap (2 inches wide minimum) connects to the Tuner Box and to the Ground Screen, all around its parameter.

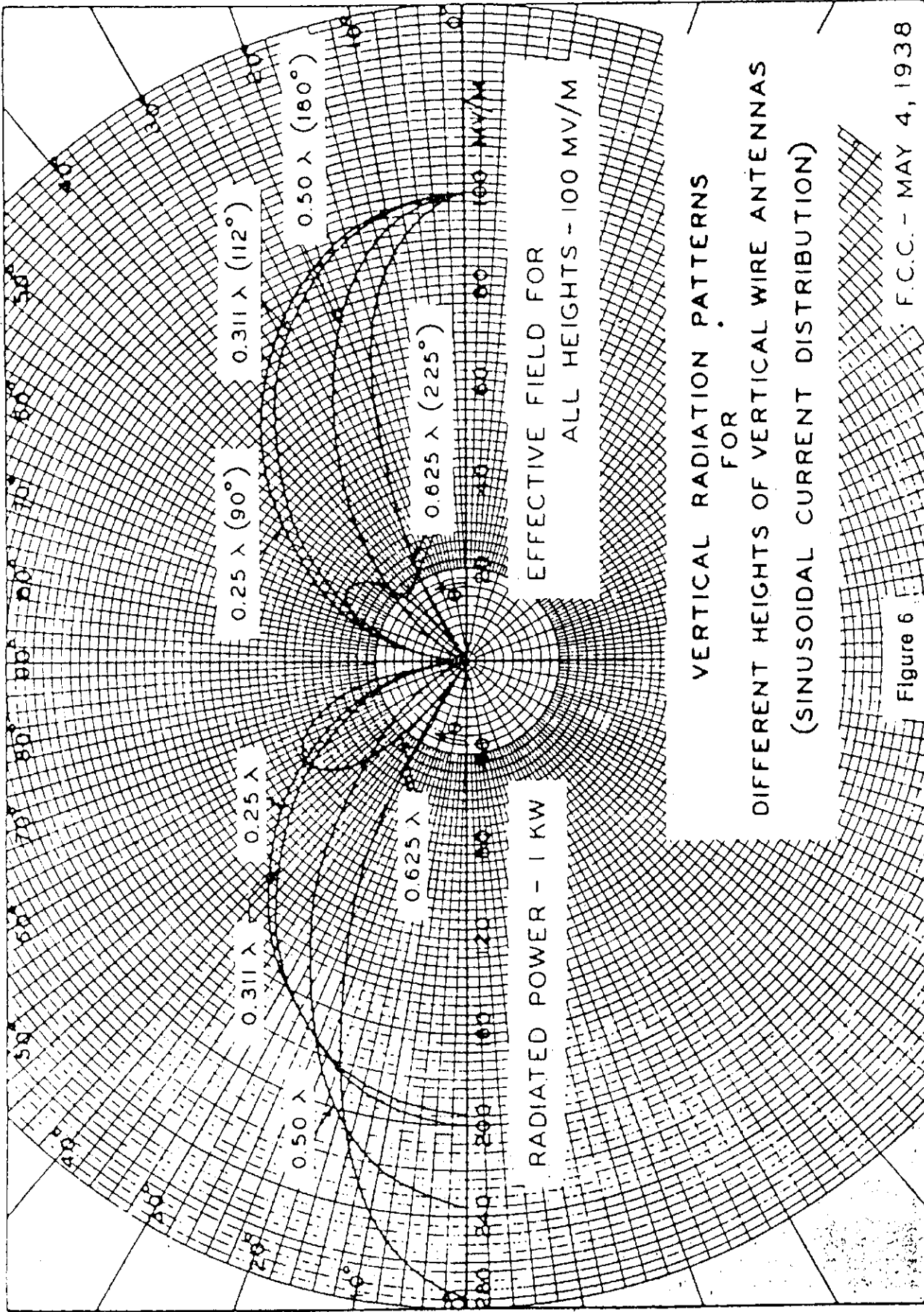

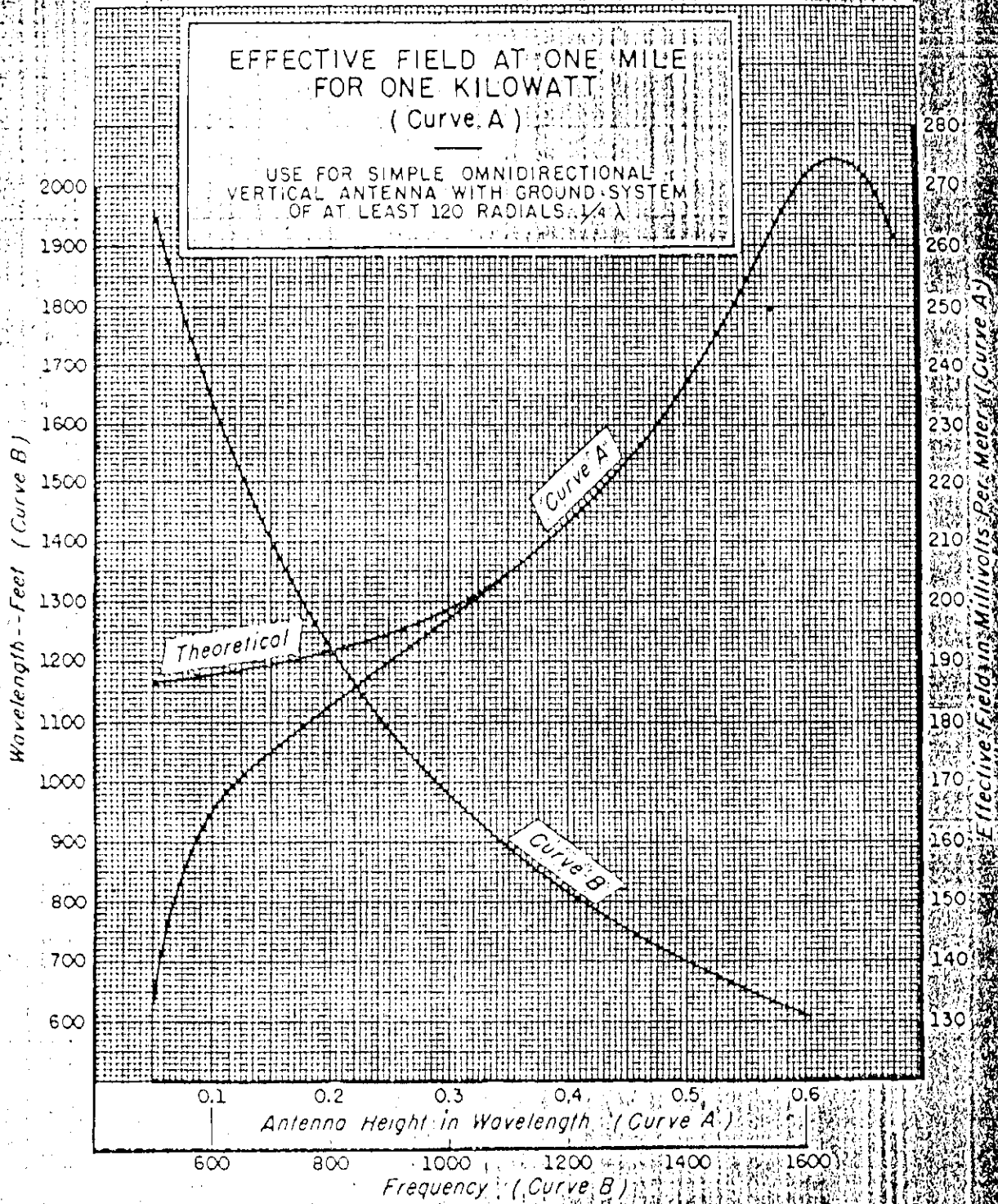

Figure 5

Normal AM Signal Strength with a Standard Ground System

Intentional Radiator

40ft mast

The insulated Guy Wires increase the overall length of the antenna system and provide better coverage.

guy wires attach to metal mast

NOTICE:  
This antenna works best for  
Frequencies above 1600 KHZ!

HOT WIRE ON TOP OF TUNER  
CONNECTS TO METAL POLE AT  
THE BASE OF THE MAST

Guys are insulated  
at bottoms

insulators

insulator

insulator

PVC PIPE INSULATOR  
(prevent mast from  
shorting to roof)

tuner box

GROUND WIRE

GROUND STAKE

GROUND WIRES UNDER SOIL OR ON TOP

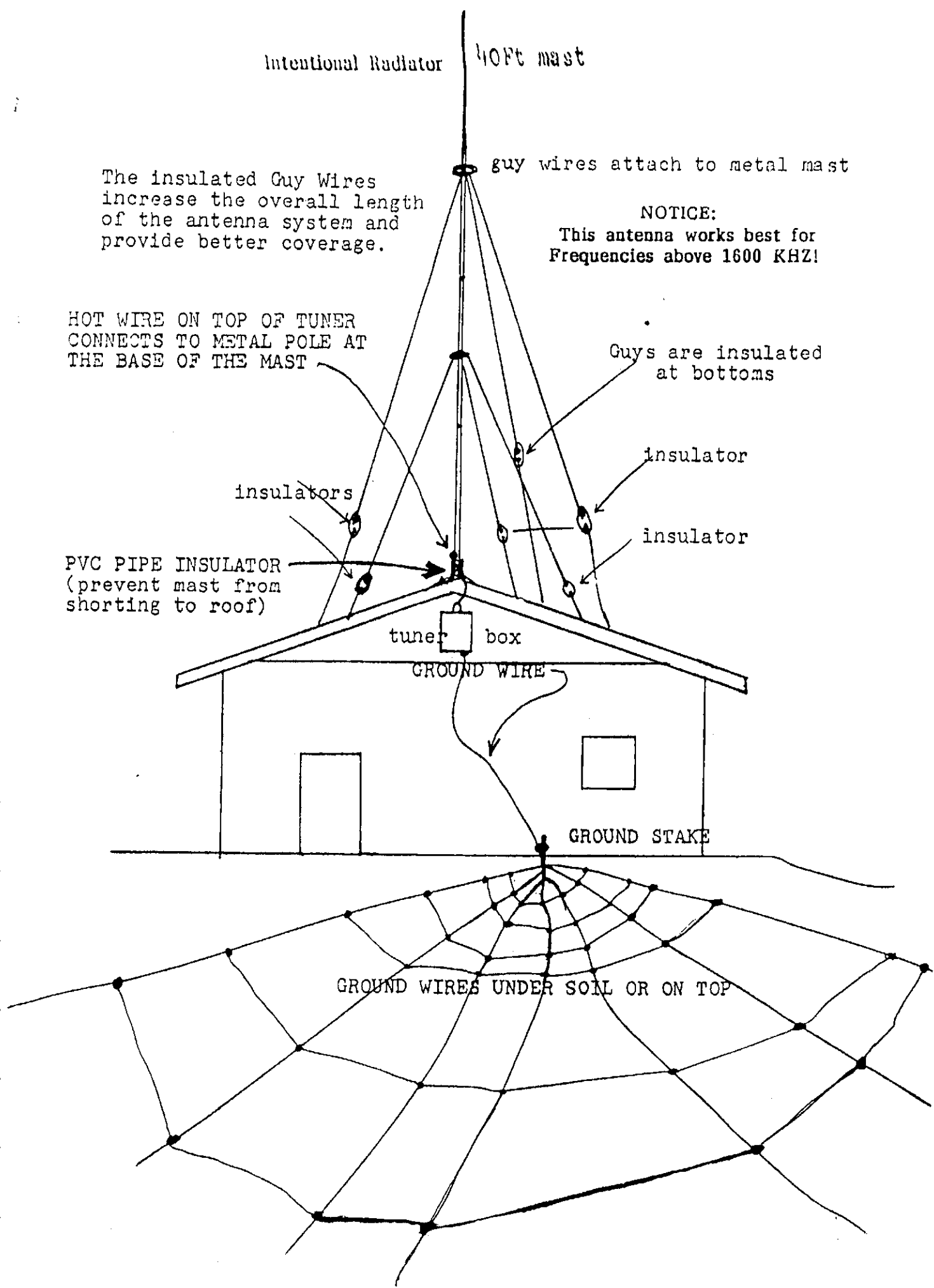

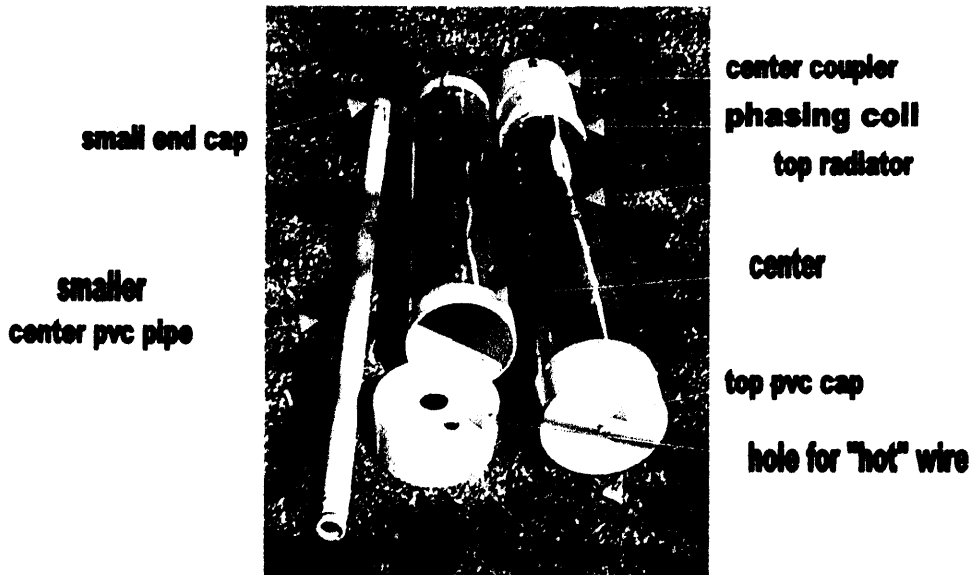

## Low Power EH Antenna

The Low Power EH Antenna is shown here ready to box up. It is made on 8 inch Diameter PVC Pipe. The pieces are 4 feet on top and 4 feet on bottom. The Top has a PVC Cap permanently attached with screws around its edge. It has 3 screws through its Center into the smaller cap on the Center PVC Pipe, which is permanently glued on. The Screws are stainless Sheet Metal Screws (not in place in this picture). The Center PVC Pipe goes to the Top Cap and through the center hole in the bottom PVC Cap. This holds it in position. There is another Hole in the Large Bottom Cap. It is for the Center "HOT" Wire that connects inside the Top PVC Tube, to a Brass Bolt that goes through the Pipe into the Metal Top Radiator. This Bolt is connected to the Phasing Coil's bottom just beneath the Top Radiator. A large diameter Wire is brought down "inside" the PVC Pipe and it passes through the smaller hole in the Bottom PVC Cap. This "Hot" Wire has a standoff insulator inside the Big PVC Pipe to keep it from getting too close to the Grounded Bottom Brass Bolt, which might cause tuning problems. This Wire is fed through the Hole made for it, and then the Bottom Cap is Screwed on around its bottom edges.

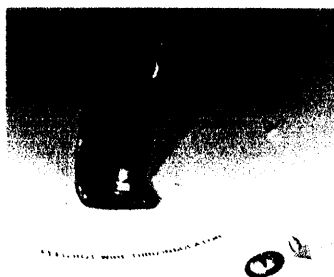

**Bottom Radiator Brass Bolt**

**Inside Insulator close to the Bottom Brass Bolt**

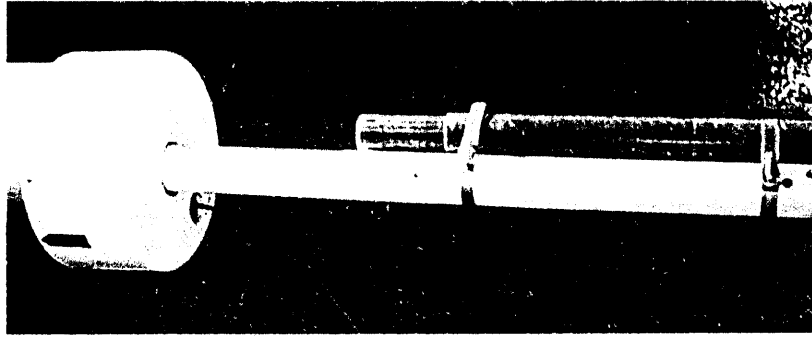

## EH With Support Tube.

Here you see the EH Antenna with the Support Tube (Center Smaller Tube) in place. It has a Fiberglass Mounting Tube attached to it. This can be a Metal Mast or other Supporting Structure, like a Radio Tower. If the EH Center Tube is Aluminum, it works very well, and is stronger than PVC Pipe. Notice the heavy duty Wire coming out of the Smaller Hole in the Bottom 8 inch diameter PVC Cap. This is the "HOT WIRE." It must be short. It goes to the Top of the Tuner Box. There is also another Wire in the picture (top center). This is longer than the "Hot" Wire. It attaches on the Top of the Bottom Radiator. It comes down to the Bottom of the Tuner Box. The Tuner Box has no ground except the Coaxial Cable. The Tuner is mounted just below the Antenna, keeping the Wires as short as possible. This is a must, or the EH will not Tune to resonance. Tests show that the total distance from the Center of the EH to the Tuner must not be greater than 12 feet.

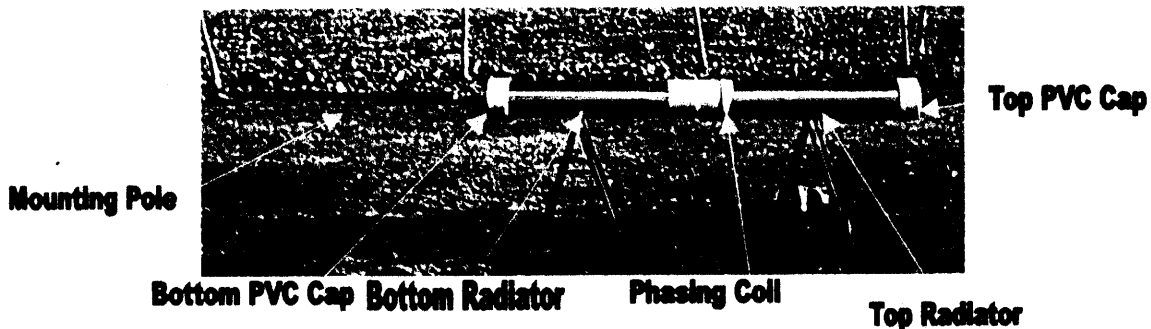

The EH Antenna can be constructed and Tests begun on supports as shown. For Final Testing, mount it above the Roof Tops, and connect the Tuner below it placed as closely as possible to the Antenna itself. Connect the Coax, Transmitter and Tuner. Tune for resonance. Use a Power/SWR Meter between the Transmitter and the Antenna Tuner and Tune the Antenna for low SWR and maximum Forward Power on the Meter.

The Center PVC Pipe can be replaced with an "Aluminum" Pipe for greater stability. Never use Steel or Iron Pipe in the Center of an EH Antenna, as it will de-tune the entire Antenna and prevent proper Radiation Characteristics.

## "J" Pole Antenna

### SPECIFICATIONS:

**GAIN:** APPROXIMATELY 3.2 db PER UNIT (3 Units for 10db)

**SIZE:** FULLY EXTENDED - 6.5 feet high

Appx. 6 inches wide

**FREQUENCY RANGE:** Any between 88MHZ and 150 MHZ.

**WIDE BANDWIDTH** - suitable for FM Broadcast

**MULTIPLE** Units produce appx. 3.34 db Gain per unit when spaced 1 wavelength apart.

Provided with UHF Connector (s) and Quality phasing cables for Multielement use.

**WEIGHT:** APPX. 3 lbs. per Unit

Length of Elements in Feet:  $(\frac{5}{8} \text{ Element}) \frac{588}{Fmhz}$

$(\frac{1}{4} \text{ Element}) \frac{234}{Fmhz}$

**WIND LOAD:**  
15(50/33 lbs. ft<sup>2</sup>)

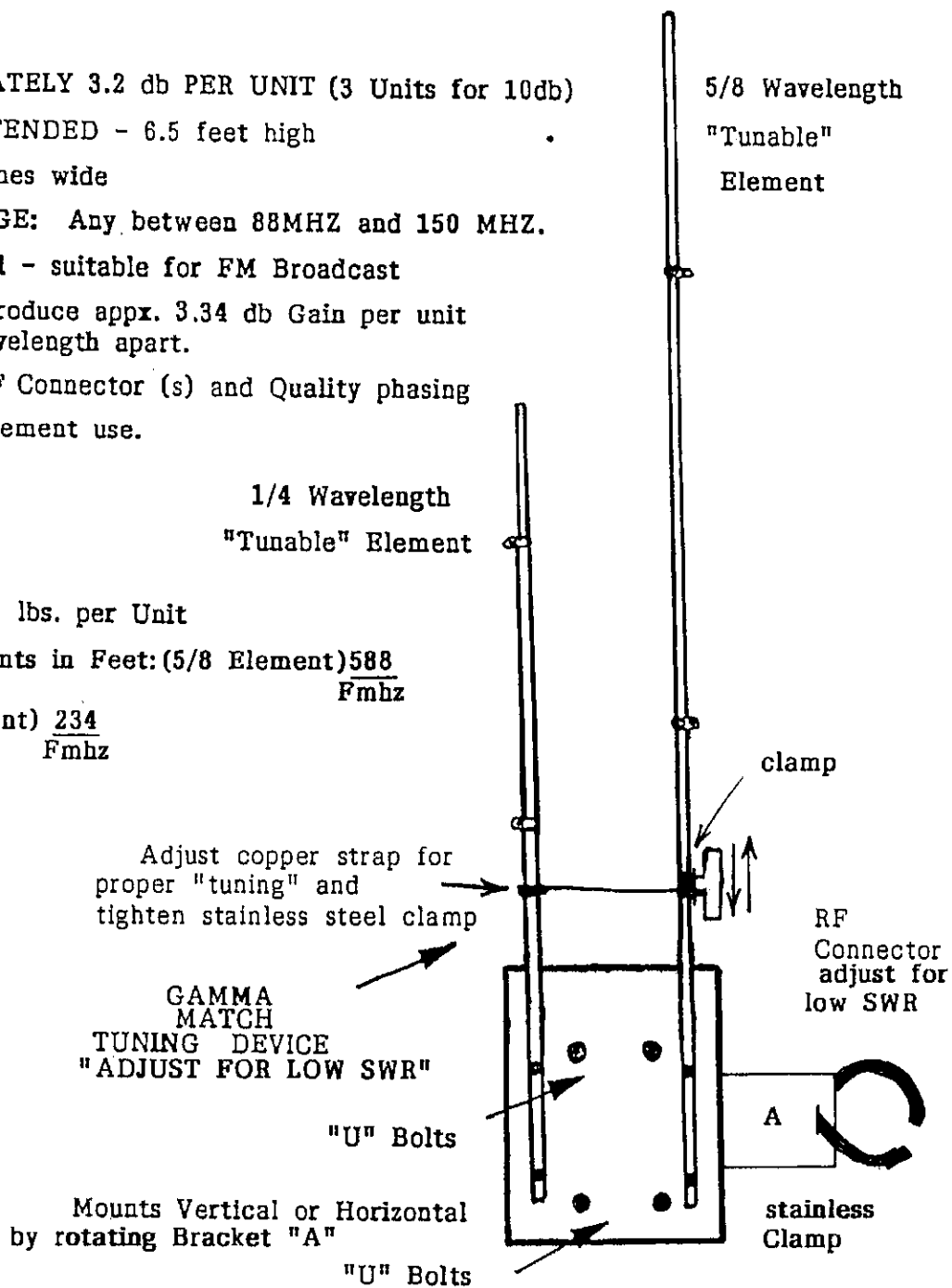

**BUILT OF HIGH QUALITY STAINLESS "AIRCRAFT" TUBING**

DESIGN by  
J.R. CUNNINGHAM  
1993- USA

### J-POLE TUNING CHART

Freq. Mhz.	Gamma Tuning "G"	Adjustable Element "A"	Special Instructions
88	6.5 inches	76.5 inches	Note #1: Choose Freq. closest to your Freq. and adjust by this Chart.
89	7"	75"	
90	7.1"	74.5"	
91	7.25"	74"	
92	7.3"	73"	
93	7.5"	72.5"	
94	7.75"	71.5"	
95	8"	71"	
96	8.25"	70"	
97	8.5"	69"	
98	9"	68.5"	
99	9.25"	68"	
100	9.5"	67"	
101	9.75"	66.5"	
102	10"	66"	
103	11"	65.5"	
104	11.25"	65"	
105	11.5"	64"	
106	11.75"	63.5"	
107	12"	63"	
108			

J-Pole Antenna

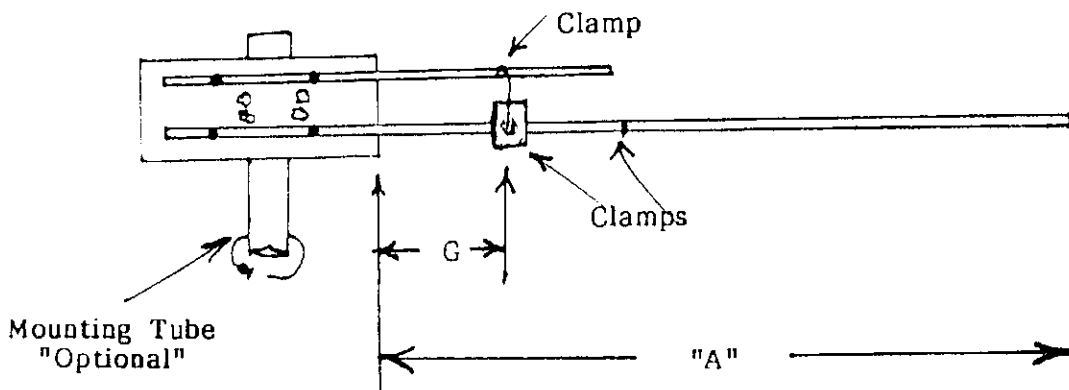

Adjust "G" for GAMMA TUNING (FOLLOW INSTRUCTIONS)  
 Adjust "A" for Antenna Length  
 Measure "G" to its CENTER (Tighten all clamps when done)



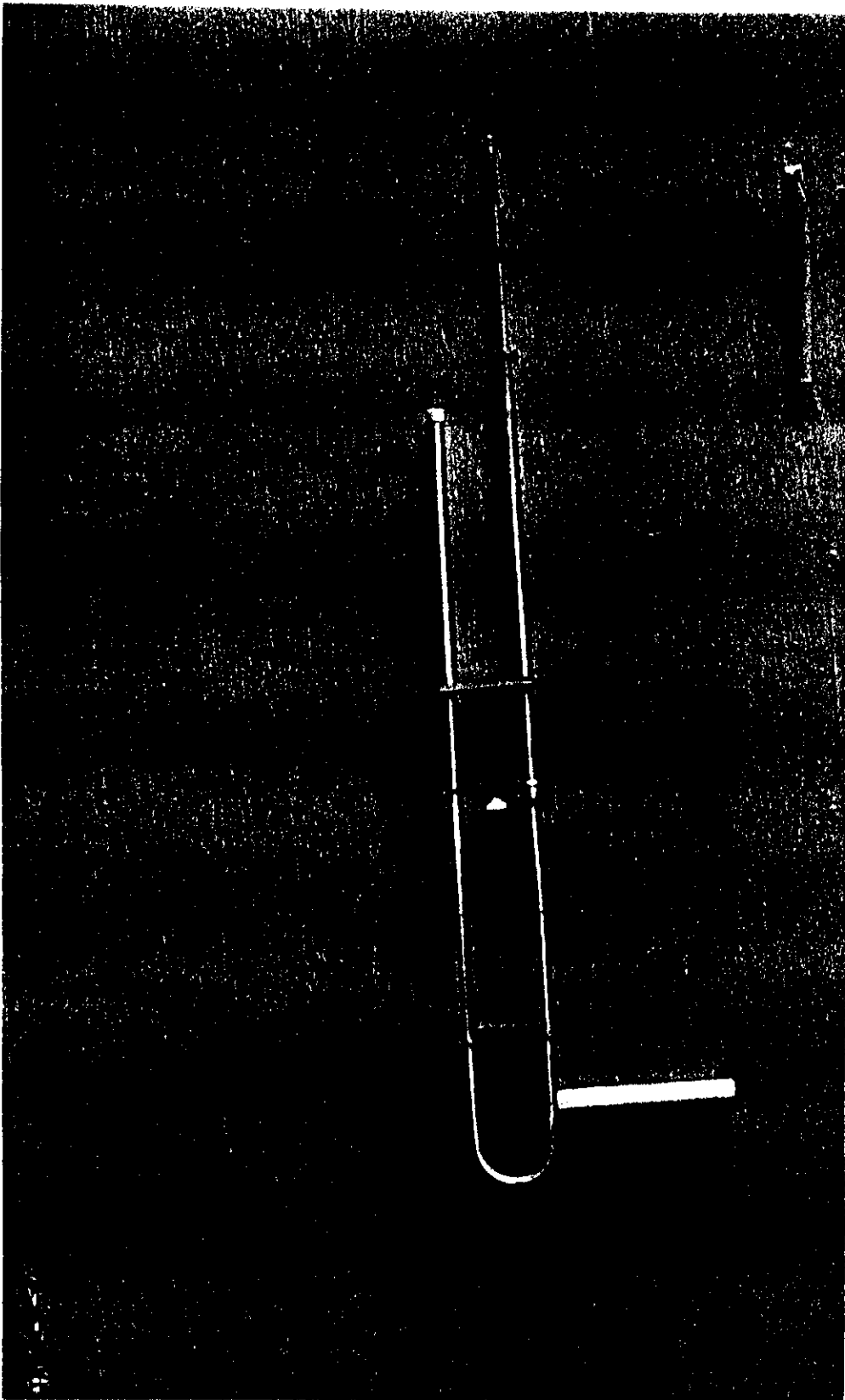



# *Southeastern*

## TECHNICAL SERVICES

BROADCAST

RADIO

MISSIONS

JAMES R. CUNNINGHAM, Broadcast Engineer

P.O. Box 8, Stonewall, OK 74871

(405)265-4496

### INSTRUCTIONS

Use SILICONE LUBRICANT TO PREVENT ELECTOLYSIS OF DISSIMILAR METALS, JOINTS AND CONTACTS.

CONTACTS OR JOINTS MUST BE "UNDER MODERATE PRESSURE" [such as a hose clamp, bolt and nuts or spring type clamps] for good electrical contact and long life to be assured.

SILICONE GREASE DOES NOT WASH OFF WITH WATER, THEREFORE IT IS IDEAL FOR ANTENNA INSTALLERS AND TOWER WORK. IT HAS BEEN PROVEN TO WORK IN APPLICATIONS IN EXCESS OF 15 YEARS OF PROTECTION OF ELECTRICAL CONTACTS AND JOINTS, HOWEVER WHERE POSSIBLE, APPLY THE SILICONE GREASE AND COVER WITH ELECTRICAL TAPE [especially BNC, UHF, and other RF SCREW ON CONNECTIONS]. This seals the connection against water or moisture.

SILICONE LUBRICANT IS AVAILABLE AT TWO WAY RADIO SHOPS, ELECTRICAL SUPPLY HOUSES AND OCCASIONALLY AT RADIO SHACK STORES.

LIFE EXPECTANCY: 25 YEARS.

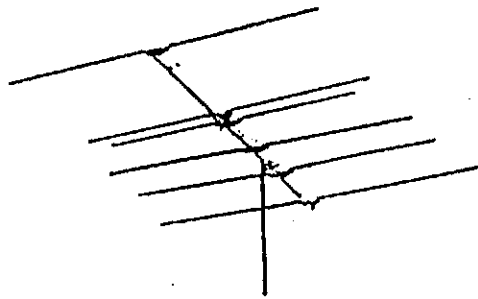

High gain  
FM-stereo antenna

This inexpensive F.M. Receive Antenna can be used as an effective TRANSMIT Antenna at powers up to 1KW (intermittent) and 300 Watts Continuous!

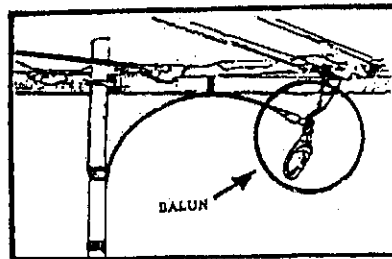

Use the Special Balun shown below, AIM THIS HIGHLY DIRECTIONAL ANTENNA IN THE RIGHT DIRECTION and your Transmit power (ERP) will MULTIPLY at least BY TEN!

### BROADBAND 88-108 MHZ TRANSMIT BALUN DEVICE

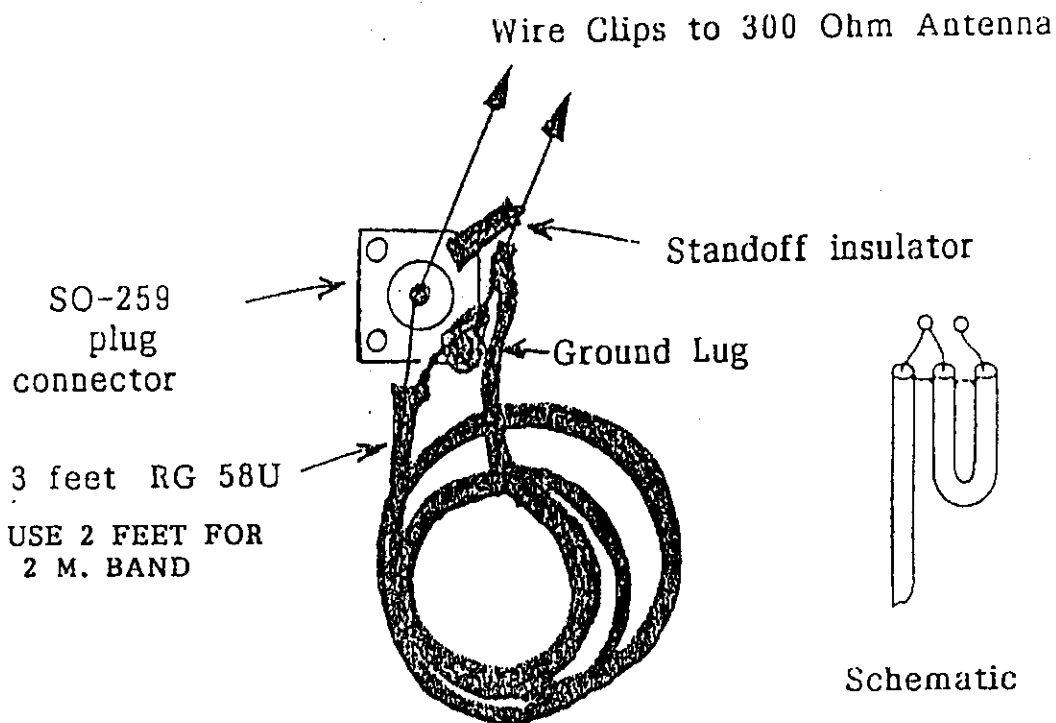

BALUN COIL FOR MATCHING 72 Ohm or 50 Ohm coax to a 300 Ohm Antenna for Receive or Transmit purposes.

NOTES: RG 8 cable may be used for the Balun if over 300 Watts of power is to be run into the Antenna.

The length of the coil of Coax is 1/2 Wavelength with the Velocity Factor of the line included in the calculation.  
 FOAM COAX - VF=.8  
 POLYETHELIN COAX - VF=.66

CP 1000 FM ANTENNA BAY  
(Field Adjustable)

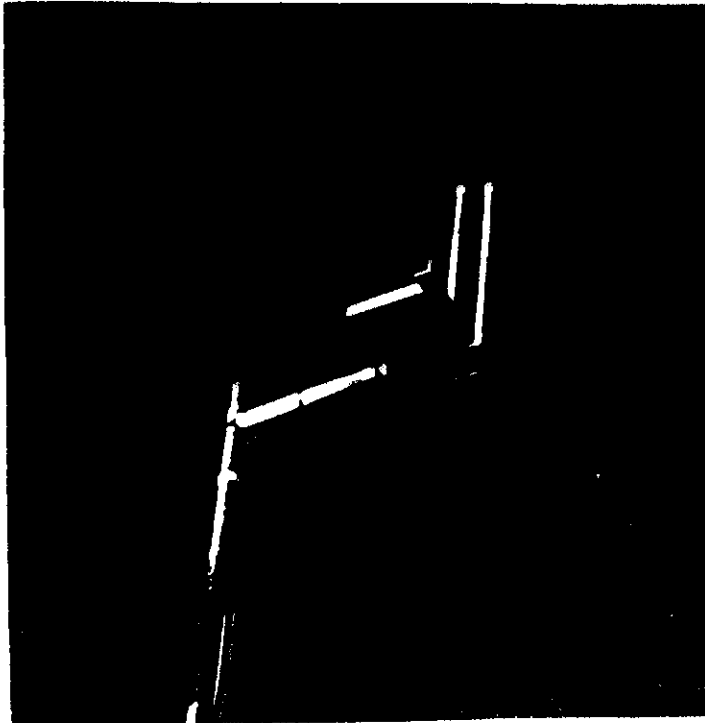

1000 WATTS MAXIMUM PER BAY

Aluminum Air Craft tubing construction allows for a light weight and sturdy FM Broadcast antenna with Circular Polarization. The CP 1000 has been tested in Africa under the most severe conditions, and has proven to be a good choice for the Low Power Radio Broadcaster.

Tunes from 80 - 150 MHz, covering FM Stereo Frequencies, PLUS Ham Radio Frequencies. Comes complete with Mounting Brackets, as shown above. Orders of two or more Antennas include phasing and Matching Cables at no extra cost, and are preset to your Frequency, as specified in your Order.

Complete Tuning Instructions come with each Antenna Bay, for easy set up in case Frequency is changed at some future date.

GAIN: .49db per Bay

Power Range: 10 Watts through 1000 Watts per Bay.

Weight: Less than 7 lbs. per Bay

THE  
 "CUNNINGHAM" UNIVERSAL BAY  
 ANTENNA  
 88 - 108 MHZ  
 1000 Watts Per Bay  
 Circular Polarization  
 Containing Both Vertical and Horizontal

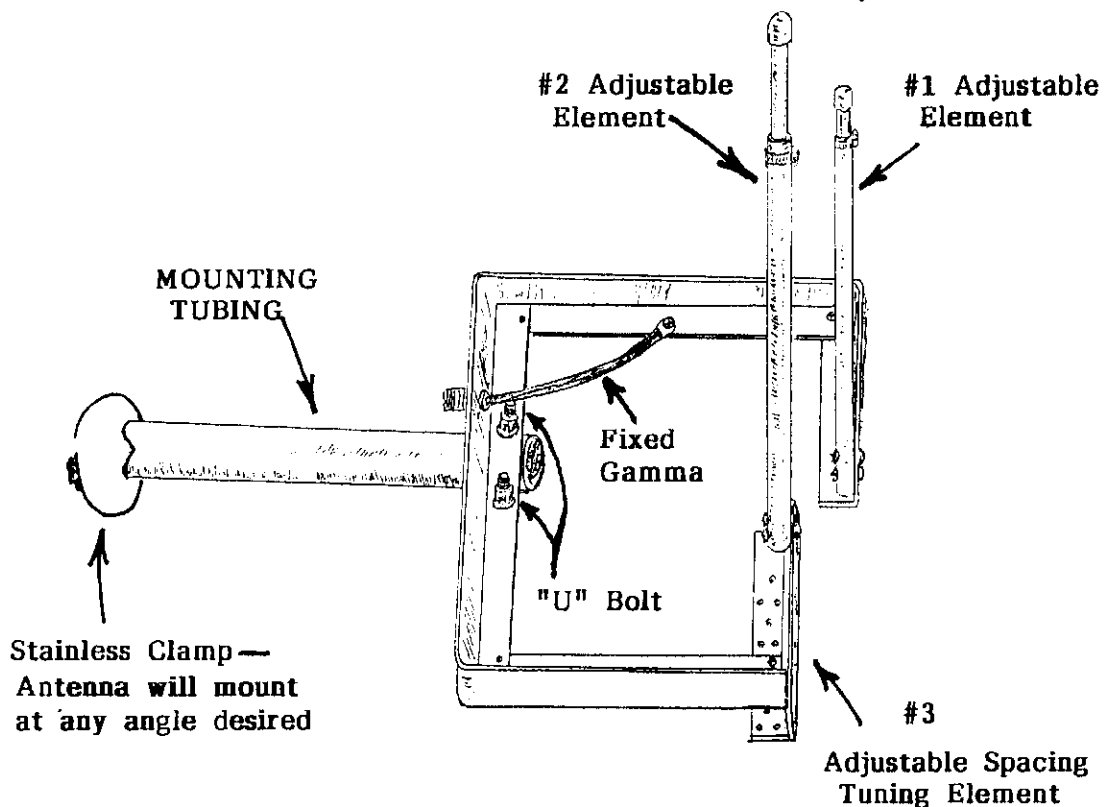

TUNING

Adjustment of Elements #1 and #2 effect the tuning over most of the F.M. Band. By adjustment of #3 "Spacing Element" it is possible to achieve a very low "SWR." This Element is adjustable at 1 inch increments by use of the Screws provided in the Element. Follow the instructions included with the Antenna for quick and easy "set up." Adjustment of Elements #1 and #2 is accomplished by loosening the Stainless Clamps provided, and sliding the inner adjustable section up or down. The GAIN PER BAY is .5 db or 2 db Gain if 4 Bays are used together with the cables provided for this purpose.

Circular Polarization - Provides for Circular Polarization, with both Components present in the Waveform.

ENGINEERING DESIGN  
 "CUNNINGHAM"  
 UNIVERSAL BAY ANTENNA

The Universal Bay may be mounted in any position. When mounted as shown, the most gain appears in the HORIZONTAL PLANE. Mounting at a 90 Degree angle from the position shown, results in a small gain in field strength in the VERTICAL PLANE. Polarization is essentially circular regardless of position.

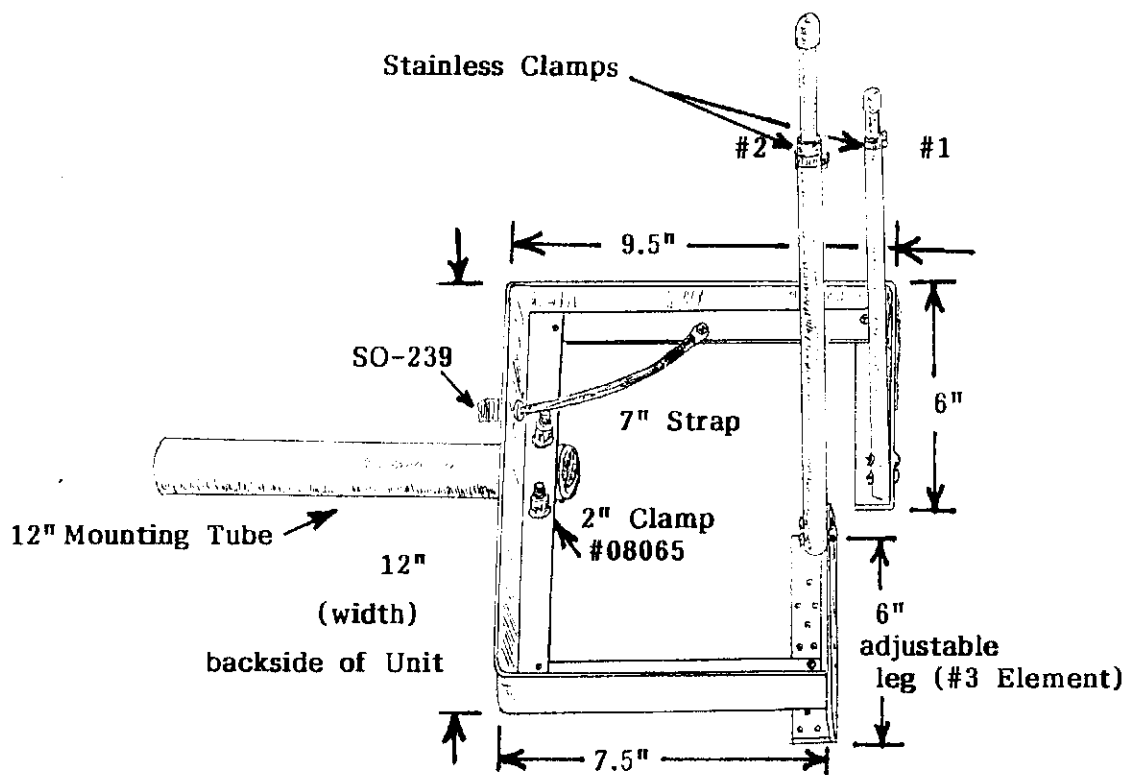

Elements #1 and #2 are identical and are each made of 1 piece of 7/8" O.D. Aluminum Tubing 12 inches long and one piece of 3/4" Aluminum Tubing (O.D.) 7.5 inches long. The shorter tubing adjusts inside the larger diameter and longer tubing, which clamps to adjustment using a stainless clamp around the outer edge.

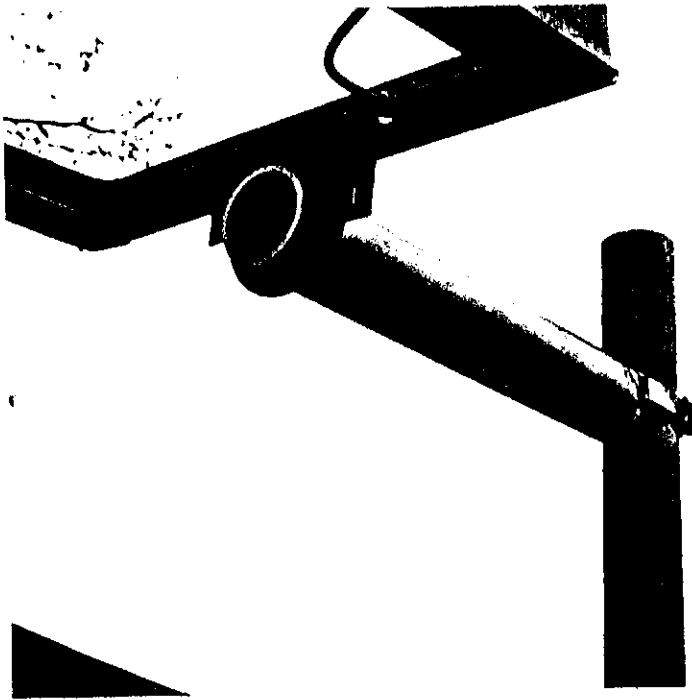

ILLUSTRATING HOW THE UNIVERSAL BAY  
CLAMPS TO A POLE OR TO A TOWER LEG

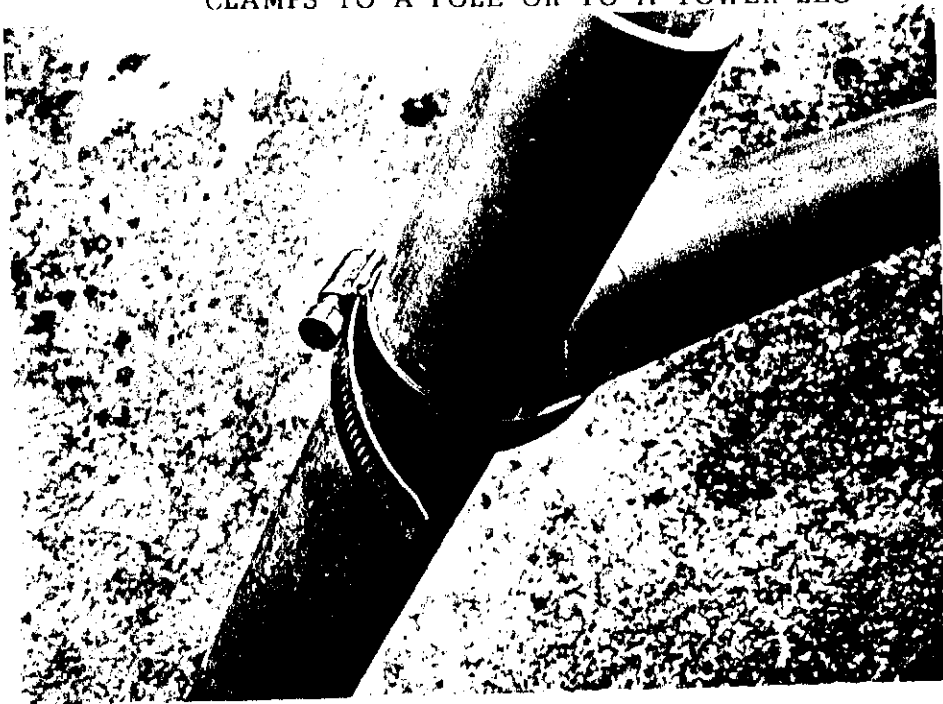

CLOSE UP VIEW OF THE STAINLESS STEEL CLAMP  
AND ITS CORRECT USE

## HOW TO MAKE POWER DIVIDERS

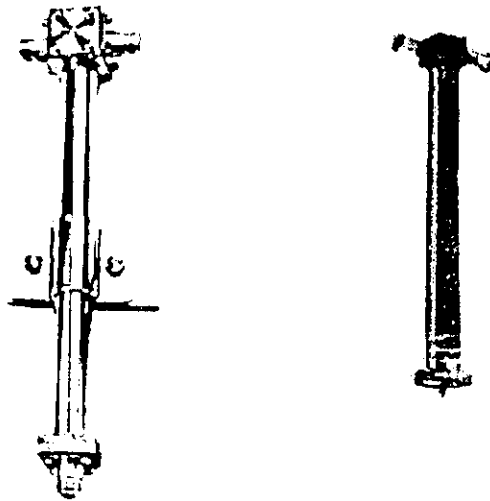

Power Dividers usually consist of a rigid piece of transmission Line with a box at the top with RF Connectors facing in different directions. All RF Connectors are wired in Parallel to each other, and the bottom RF Connector connects directly to the center of the Transmission Line.

Power Dividers can be made from Flex Line or various sizes of Coaxial Cable, with similar results.

### FORMULA FOR LENGTH

Tip to Tip Measurements are as follows:  $\text{Length} = 234/\text{Fmhz}$ . The answer is in FEET. Multiply by 12 for INCHES. Power Dividers are usually  $1/4$  Wave Length.

Input Impedance is 50 Ohms and Output Impedances are 50 Ohms.

INSERTION LOSS - Low Power Units using  $1/2$  inch diameter Tubing or Coax has a loss of about .2db max. LARGER DIAMETER POWER DIVIDERS HAVE A MAXIMUM OF .1 db loss.

### SCHEMATIC

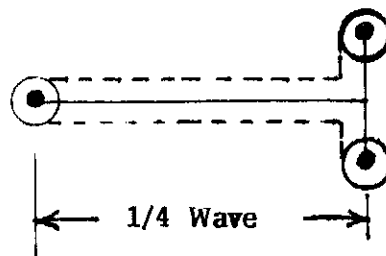



## HOW TO SPACE ANTENNA BAYS

1. Spacing is determined by the VELOCITY CONSTANT of the Transmission Lines that inner-connect the Bays (the Inner-Bays).
2. If the Velocity Constant of the Line is .66 (66 Percent), then each Antenna Section is spaced at .66 Wave Length.

### FORMULAS

Full Wave Spacing:  $984/\text{Fmhz} \times \text{Vel. Constant of Line.} = \text{Spacing in Feet.}$

1/2 Wave Spacing:  $492/\text{Fmhz} \times \text{Vel. Constant of Line} = \text{Spacing in Feet.}$

SPACING IN METERS:  $300/\text{Fmhz} \times \text{Vel. Constant of Line} = \text{Spacing in Meters.}$

3.28 times Meters gives FEET.

### COMMON VELOCITY CONSTANTS OF COAX

1. RIGID SOLID COPPER LINES - .85 or 85%
2. FOAM CENTER COAXIAL CABLES - .88 or 88%
3. POLYURETHENE OR OTHER SOLID CENTER LINES - .66 or 66%
4. For other Types, consult Mfgr. Specs.

### 3 ELEMENT YAGI DESIGN

#### REF DRIVEN DIRECTOR

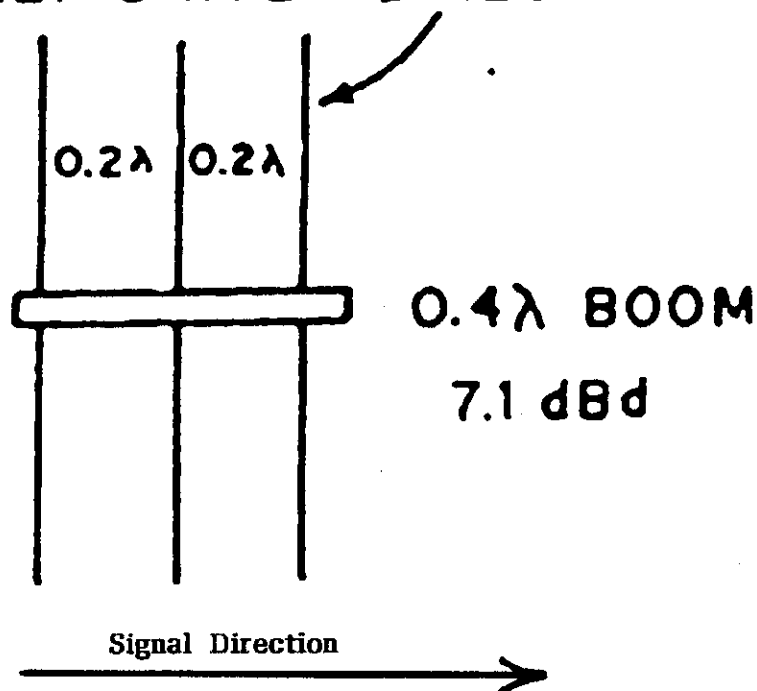

$$\text{Driven element length (ft)} = \frac{475}{f(\text{MHz})}$$

$$\text{Director length (ft)} = \frac{455}{f(\text{MHz})}$$

$$\text{Reflector length (ft)} = \frac{500}{f(\text{MHz})}$$

These are average lengths determined experimentally for elements having a diameter of  $\lambda/400$  to  $\lambda/800$ , and with element spacings from  $0.1$  to  $0.2 \lambda$ .

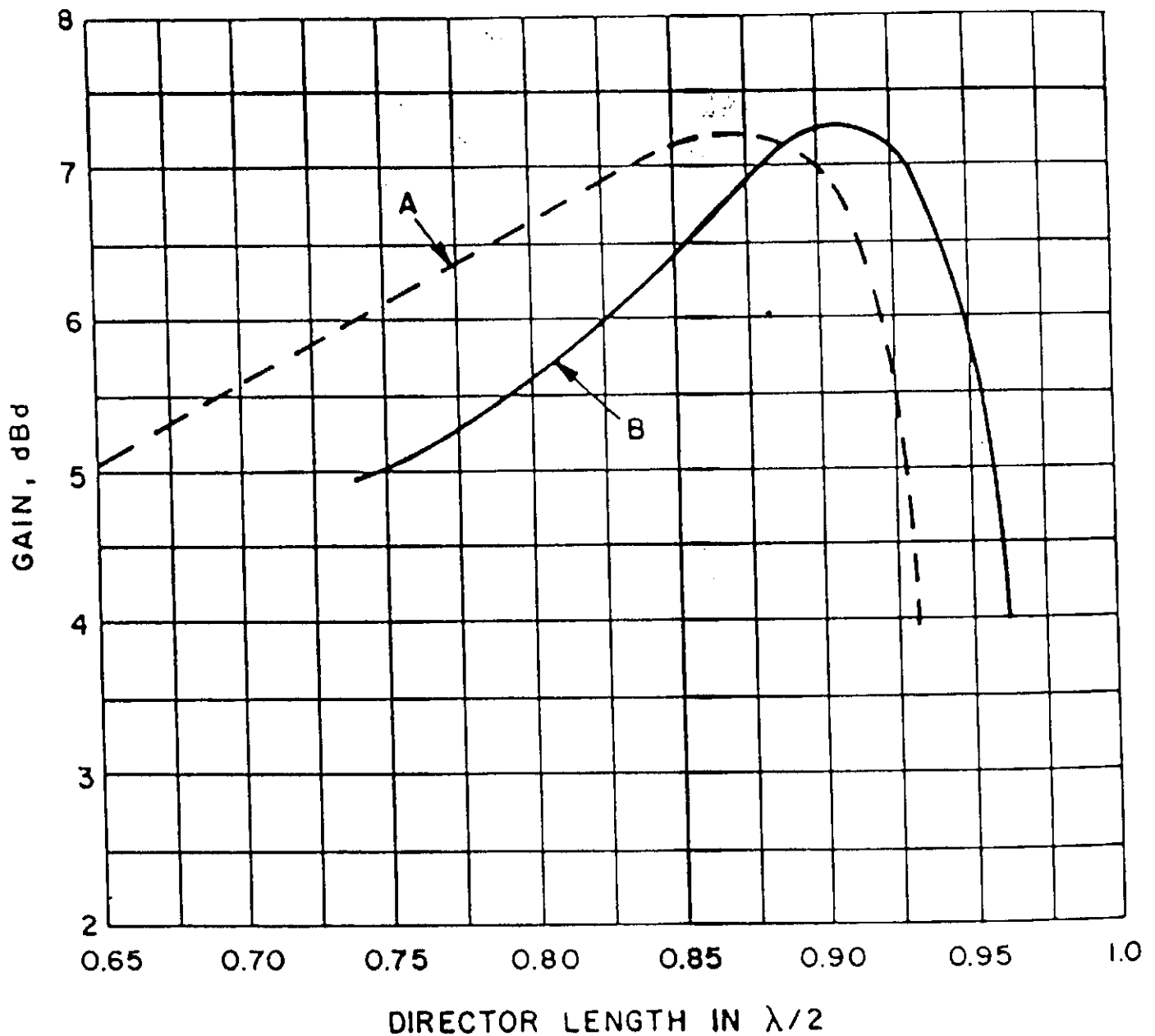
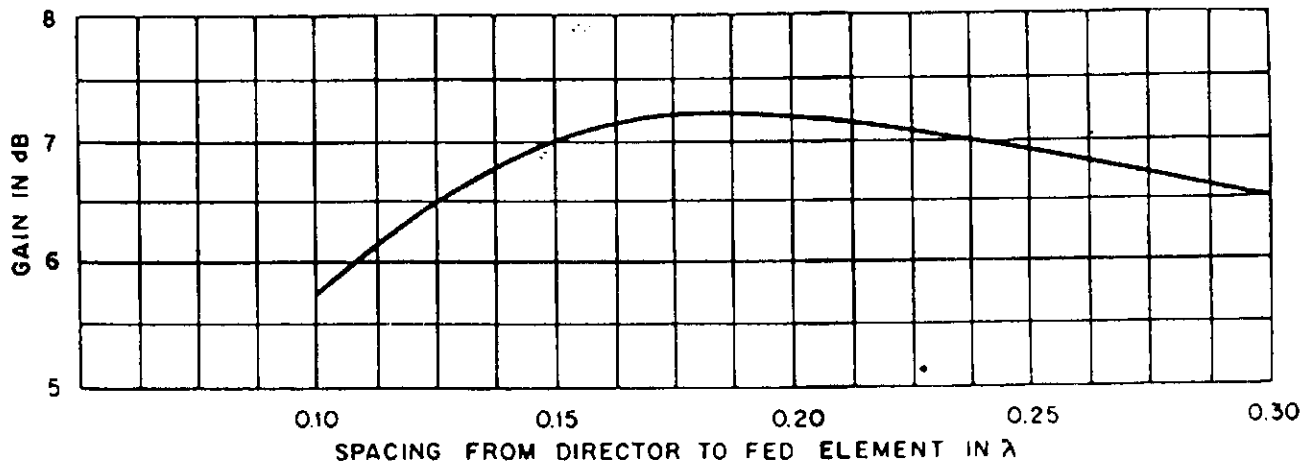

Fig 14—Gain of a three-element Yagi over a dipole as a function of the director length for  $0.2\lambda$  spacing between driven element and director and between driven element and reflector. These curves show how the element thickness affects the optimum length. Curve A is for an element diameter of  $\lambda/50$ , while Curve B is for a diameter of  $\lambda/500$ . (A diameter of  $\lambda/500$  is approximately  $\frac{1}{2}$  in. at 50 MHz.) Where the relative diameter is smaller, as on the lower frequencies, the optimum director length will be somewhat greater.



**Fig 15—Gain of three-element Yagi as a function of director spacing; the reflector spacing is fixed at  $0.2 \lambda$ . (Curves of Figs 14 and 15 are from work of Carl Greenblum.)**

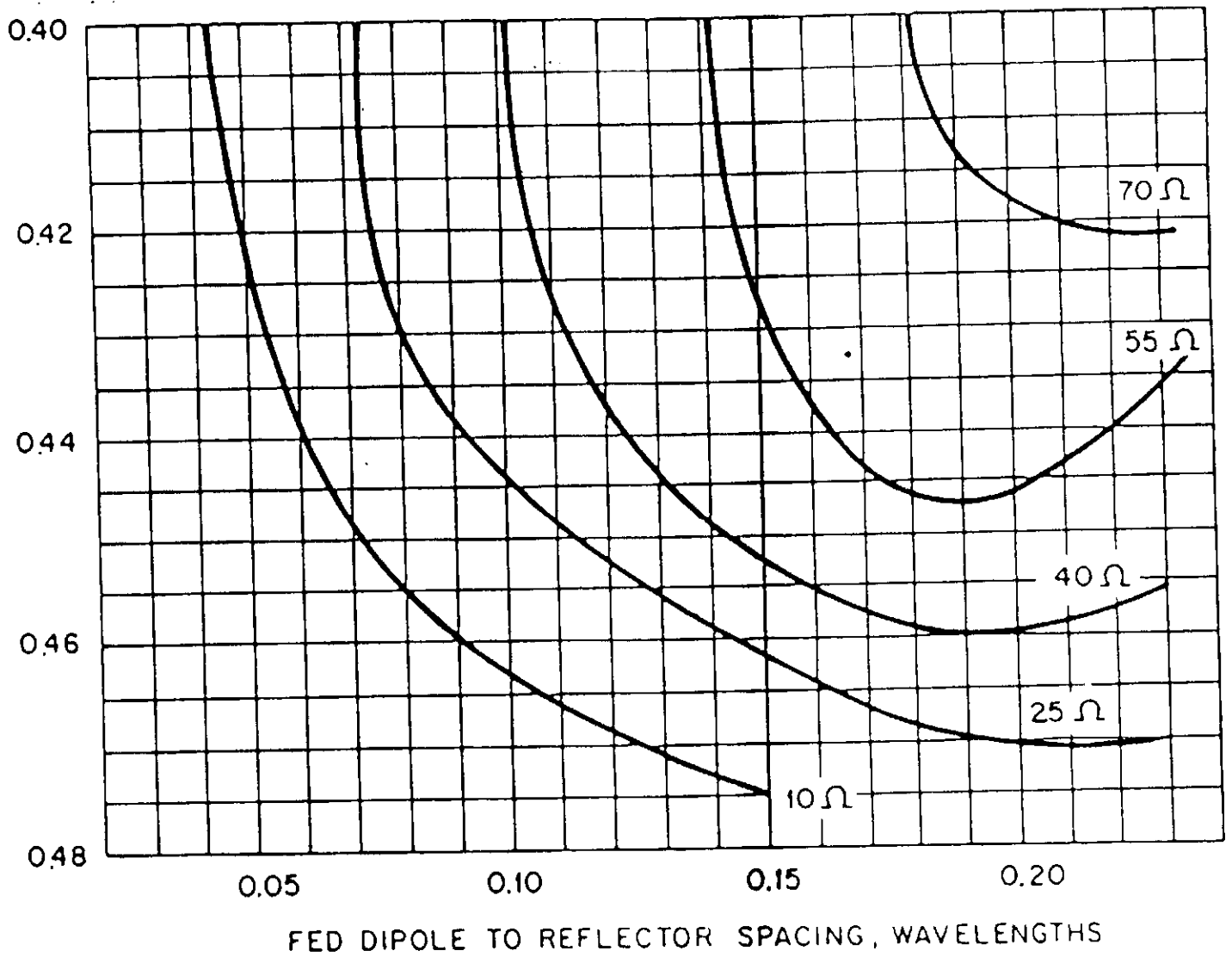

Fig 16—Resonant resistance of the driven element in a three-element parasitic antenna, overall length  $0.3\lambda$ . (Based on measurements by J. P. Shanklin.)

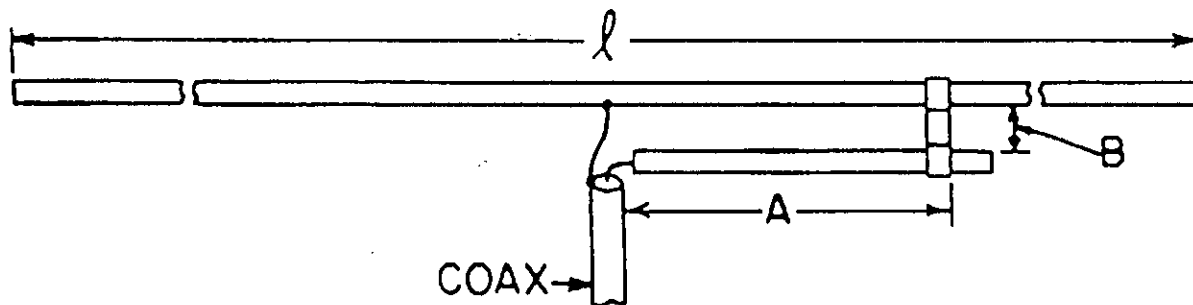

Fig 29—The gamma match, as used with tubing elements. The transmission line may be either 50- $\Omega$  or 75- $\Omega$  coax.

#### CALCULATIONS

L - The total length of "L" is usually  $1/2$  wavelength but no more than  $5/8$  Wavelength. The length of "L" may be adjusted to control the amount of reactance at the Feedpoint.

A - THE LENGTH OF THE GAMMA MATCH SHOULD BE FROM  $.04$  WAVELENGTH TO  $.05$  WAVELENGTH. This should be adjustable for tuning.

B - The spacing between the Gamma and the driven element is  $.007$  wavelength.

DIAMETER OF "A" should be no less than  $1/3$  that of "L."

MATCHING TO 50 OHM COAXIAL LINE SHOULD BE EASY USING THIS METHOD.

#### OPTIONAL CAPACITOR

An optional capacitor may be used between the center conductor of the coax and "A" for ease in tuning. Its value is: 7 PF. PER METER OF WAVELENGTH.

USING "RABBIT EARS"  
FOR A TRANSMIT ANTENNA  
88-150 MHZ

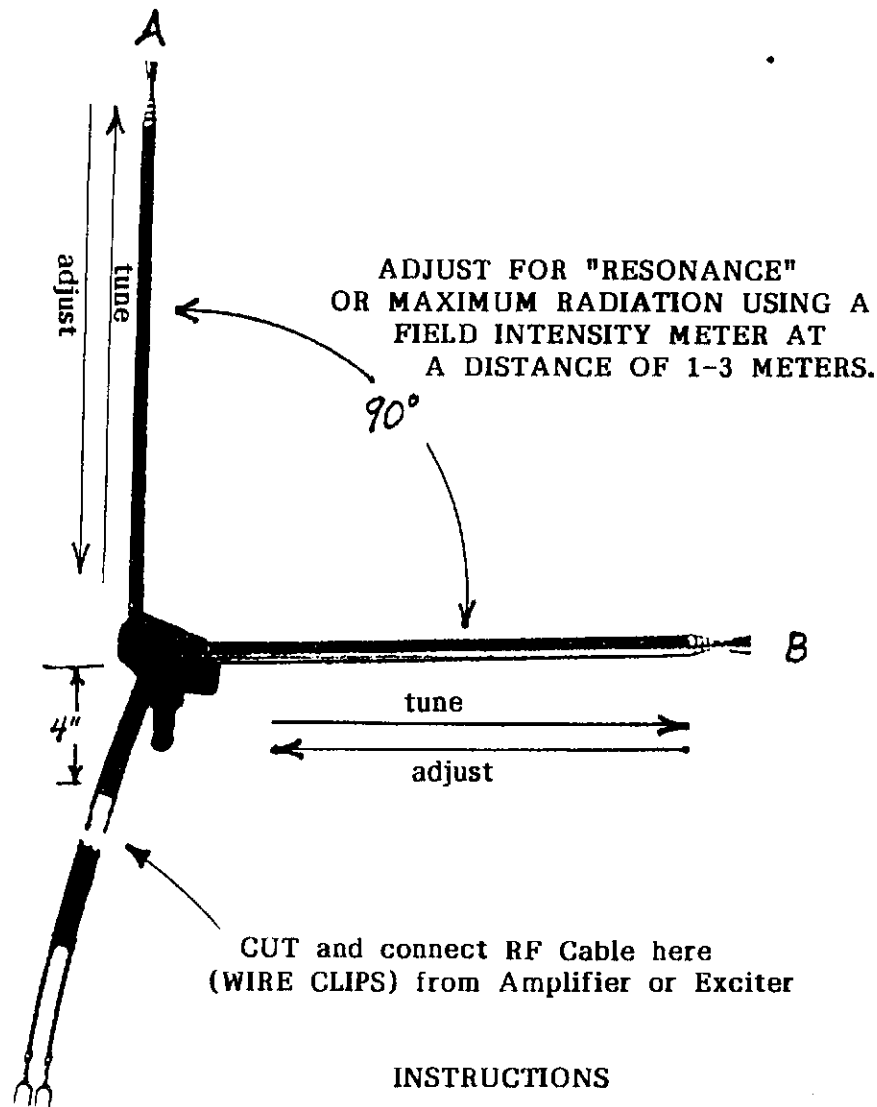

Cut "twin Lead" (300 Ohm flat wire) at a distance of 4 inches from the base of the Antenna. Connect 50 or 72 Ohm coax to this Point using wire clips. "Tune" the Antenna for MAXIMUM RADIATION. This will be "Resonance" or lowest SWR and will match the Antenna to the Transmitter very well. Do not exceed 100 Watts Power for Continuous Operation or 1000 Watts for Transceivers.

FREQ.  
Low

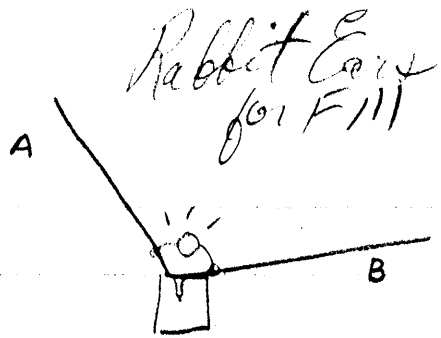

- FM -

TUNING LIGHT LAST.

LENGTH "A"      LENGTH "B"

28.1	31"	28
89.1	31"	28
90.1	31	28
91.1	31	28
92.1	30	27"
93.1	30	27
94.1	30	27"
95.1	30	27
96.1	29	26
97.1	29	26
98.1	29	26
99.1	29	26
100.1	28	25
101.1	28	25
102.1	28	25
103.1	28	25
104.1	27	24
105.1	27	24
106.1	27	24
107.1	27	24
108.1	26"	23"

1. Tuning light at base of ANT. AS SHOWN
2. Tune ANT. FOR "MIN." GLOW ON LIGHT. ANT. IS TUNED.
3. Tune XMITR. AMP. FOR "MAX" GLOW ON LAMP. THIS IS DONE LAST, AFTER TUNING ANT.
4. CHECK ANT. TUNING AGAIN FOR "MIN." GLOW ON LIGHT
5. Remove LIGHT FROM ANTENNA