

# USING ELECTRONICS

a book of things to make

## USING ELECTRONICS

a book of things to make

HARRY ZARCHY  
illustrated by the author

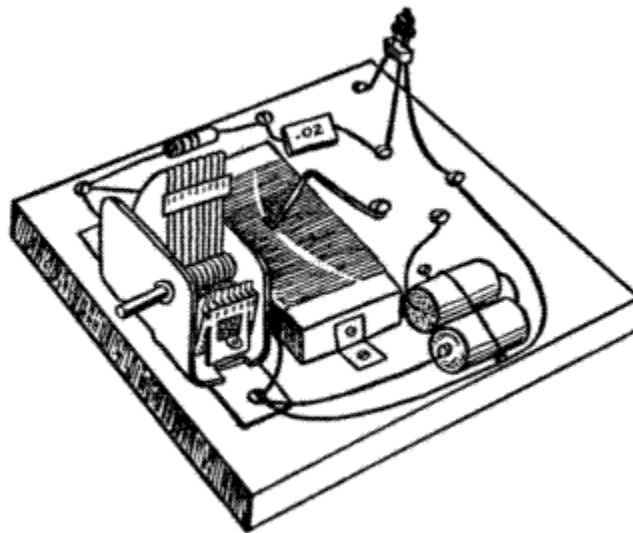

THOMAS Y. CROWELL COMPANY

NEW YORK

by the author

WHEEL OF TIME  
USING ELECTRONICS

a book of things to make

Copyright 1958 by Harry Zarchy

All rights reserved. No part of this book may be reproduced in any form, except by a reviewer, without the permission of the publisher.

Manufactured in the United States of America by the H. Wolff Book Manufacturing Company, Inc. Library or Congress Catalog Card No. 58-0721

First Printing

For Bill and Steve,  
who are off to a good start  
in electronics

## CONTENTS

The Nature of Electricity  
Basic Procedures  
Antennas and Grounds  
Radio Components  
Construction Hints

### Electronics Experiments

- (1) Simple Crystal-Detector Receiver
- (2) Crystal-Detector Receiver with Hand Wound Coil
- (3) "Emergency" Crystal-Detector Receiver
- (4) Crystal-Detector Receiver with Tuned Circuit
- (5-9) Simple Transistor Hookups
- (10) Single-Transistor Receiver with Hand-Wound Coil
- (11) Crystal-Detector Receiver with Transistor Amplifier
- (12) Two-Transistor Receiver
- (13) Two-Transistor Receiver
- (14) Two-Transistor Receiver
- (15) Single-Transistor Regenerative Detector Receiver
- (16) Two-Transistor Regenerative Detector Receiver
- (17) Solar Battery Power Supplies
- (18) Sound Amplifier
- (19) Room-to-Room Communicator
- (20) Wireless Broadcast Oscillator

### How a Vacuum Tube Works

- (21) Vacuum-Tube Grid-Leak Detector Receiver

(22) One-Tube Regenerative Receiver

How to Learn the Code

(23) Code Practice Oscillator

Index

## **USING ELECTRONICS a book of things to make**

### **THE NATURE OF ELECTRICITY**

This is a book for young people who would like to work with electronics but have had no previous experience. Anyone who can follow the simple directions in this book will be able to build radio receivers and other experimental devices described later.

Parts used in radio construction will be identified and their uses explained, so that you will know how they function in each circuit. You will also learn how to use and care for tools necessary in our electronics experiments.

Electricity is a form of energy that travels through wires. Electronics is concerned with electrical energy that travels through space. In order to understand electronics it is first necessary to understand electricity.

The ancient Greeks knew that rubbing a piece of amber with a cloth would cause it to attract bits of feathers and other matter. For hundreds of years this attraction remained unexplained and was simply regarded as one of nature's curiosities.

In the sixteenth century William Gilbert, one of Queen Elizabeth's physicians, became interested in the behavior of amber. As a result of his experiments he determined that many substances, such as sulfur, sealing wax, rock salt, and glass, had the same properties as amber: when rubbed with a cloth they attracted other substances. This phenomenon became known as electricity, after *elektron*, the Greek word for amber.

Gilbert published a book, in which he described his work. Other scientists became interested in the problem. Bit by bit they unlocked nature's secrets to arrive at a better understanding of the nature of electricity. Some discoveries were made accidentally, but most were the result of careful, painstaking investigation. Theories were developed and laws were formulated concerning the behavior of electricity; the study of electricity became a recognized science.

We may be certain that none of these early experimenters had the faintest notion that he was contributing toward the development of a force that would one day change the face of the earth. Could any one of them have predicted the electric light, radio, or television? Could Gilbert possibly have known that his interest in the curious behavior of amber would one day furnish the world with undreamed-of power?

Yet that is exactly what has happened. The twentieth century has become the age of electricity. We have become the masters of a mighty force which furnishes us with power on such a vast scale that many phases of modern life depend upon it. Electricity has become so important to our civilization that we cannot possibly do without it. It does our heavy work in mines and factories. It runs machines which eliminate much of the drudgery of farm life. Electrical appliances in our homes perform chores by the dozen; among other things they make our toast, give us light, condition our air, refrigerate our

food, and wash our clothes.

Electricity is responsible for the development of the transportation industry. Automobiles, airplanes, trucks, and buses use internal combustion engines in which power is developed when an electrical spark explodes a mixture of gasoline and air. Every motorist knows what would happen if his battery were to break down. It would have to be replaced before his car could run again.

Perhaps the most startling developments have been made in the field of communications. Electricity has made possible the development of the telegraph, telephone, radio, and television. A flip of the switch can bring us entertainment, an educational program, or the latest news bulletin. On-the-spot reporting enables us to hear or see radio or television broadcasts of events as they are taking place, even though they may be thousands of miles away! These things have become so commonplace that we attach no great importance to them. Electricity, radio, and television are part of our lives; and we seldom think about the wonderful inventions that have made them possible.

How does electricity work? Until very recently no one had the answer to this question. Now scientists attempt to answer it with the electron theory.

According to the electron theory, all matter (anything that has weight and takes up space ) is composed of molecules. If you were to break up a crystal of salt into very tiny particles, then keep on subdividing these particles into still smaller particles, you would eventually end up with molecules of salt. A molecule is the smallest possible particle of a substance that retains all the properties of that substance. Needless to say, molecules are too small to be seen.

Molecules are composed of still smaller bodies called atoms. The atom is the smallest particle into which substances known as elements can be divided. Scientists have found 92 elements occurring in nature; all known natural substances are composed of combinations of these elements. For example, a molecule of water contains atoms of hydrogen and oxygen. Other molecules have more complicated structures; borax is made up of atoms of sodium, boron, oxygen, and hydrogen.

The structure of the atom is particularly interesting, for it is electrical in nature. Physicists have discovered that atoms are not solid bodies but are composed mainly of empty space. Each atom has a core, or nucleus, which contains positively charged particles called protons, and neutrons, which are electrically neutral particles. Revolving around the nucleus are one or more particles with a negative charge; these are electrons.

The atom has been compared to the solar system, with the electrons (planets) whirling around the nucleus (sun). This comparison is even more striking when we learn that the electrons revolve around the nucleus in definite paths, or orbits. Consequently, they are said to have a planetary motion.

Atoms are electrically neutral. Each positively charged proton in the nucleus is usually balanced by a negatively charged electron. Illustrations of the atoms of different elements show this clearly. The hydrogen atom has the simplest structure; its nucleus contains one proton which is balanced by one planetary electron. The helium atom has two neutrons and two protons in its nucleus and is encircled by two electrons. Uranium has the most complex structure of all the elements; it has ninety-two planetary electrons which revolve around the nucleus in seven different orbits.

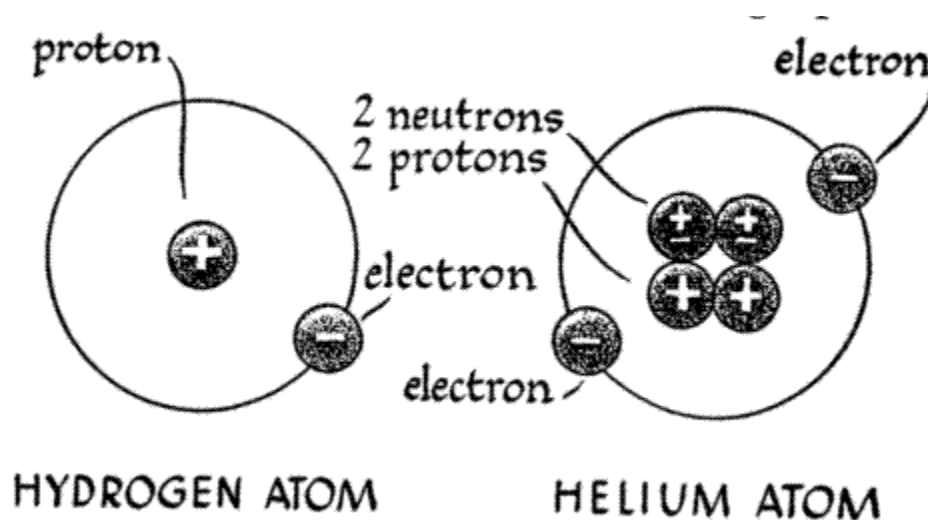

In some elements the electrons in the outer orbit are held together very loosely. Under certain conditions one or more are forced free and are able to move from one atom to another. These are called free electrons. When an atom gains or loses electrons, it is no longer electrically balanced, or neutral; it has become ionized. An atom that has lost electrons is left with a slight positive charge and is known as a positive ion. A negative ion is an atom that has gained electrons and has a negative charge.

The movement of free electrons in a conductor constitutes an electric current. An electron moves a very short distance and then collides with a nearby atom. It forces one or more electrons out of their orbit and takes their place. The replaced electrons, now free, move on to repeat the process with other atoms. This movement of free electrons takes place throughout the substance that is conducting the electric current.

Some substances contain large numbers of free electrons. These substances are called conductors of electricity because they permit electrons to flow through them very easily. Metals such as silver, gold, copper, brass, aluminum, zinc, and iron are conductors. Although silver is best, copper wire is generally used in electrical work because it is considerably less expensive.

Other substances such as asbestos, rubber, mica, dry wood, and glass have very few free electrons and consequently permit practically no current to flow through them. They are known as insulators. Insulating materials are used as coatings or wrappings on wires that carry electric current.

In order for a conductor to carry current, it must be part of a complete electrical circuit. Try this experiment: touch one end of a copper wire to the bottom of a flashlight bulb, and the other end to the side of the bulb. Since the wire contains an abundance of free electrons, you might expect current to flow and light the bulb □ but nothing of the sort will happen. The bulb will not light because the free electrons in the wire are vibrating aimlessly in all directions instead of moving in one direction. A source of electrical energy is needed to start the flow of current; this will make our circuit complete.

Electrical energy can be furnished by an ordinary drycell battery, such as is used in a flashlight. It acts as a pump and starts the current flowing in a circuit. Batteries are made in several sizes; No. 6 dry cells are often used for electrical experiments. The battery (strictly, "battery" should be used only for two or more cells) goes to work as soon as it becomes part of the circuit. Electrons rush to the negative terminal (-□) and excite free electrons in the conductor. At the same time the positive terminal (+) begins to attract excess electrons from the other end of the conductor.

Electrons within the circuit no longer move about in a haphazard manner but commence a steady drift, or flow, in one direction. They move from the negative terminal, through the conductor and lamp, and back into the cell through the positive terminal; current flows in the circuit and the lamp will light. Should any one of the connections be broken, the circuit will be incomplete and the flow of current will stop.

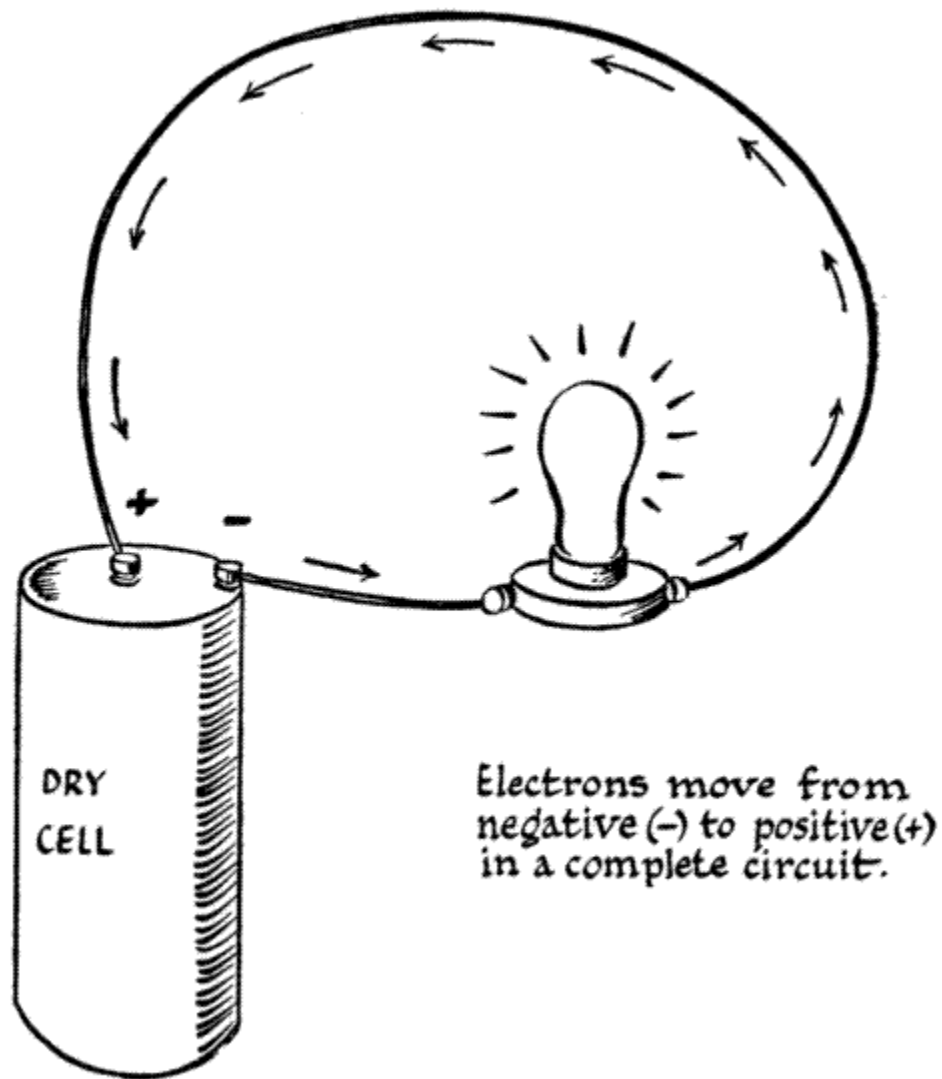

Electrons migrate through the conductor rather slowly, but the electrical energy they produce is transmitted at the speed of light—about 186,000 miles per second! This can be explained if you will imagine a row of marbles arranged in a straight line so that they are all touching. Strike the marble at one end and the impact will immediately be transferred to the one at the opposite end.

Something very similar takes place in a complete electrical circuit. As soon as the cell begins to push electrons into one end of a conductor, other electrons are forced out of the opposite end.

Wires can be used to carry signals. This is really very commonplace, for every time you press a doorbell push button you are sending a signal along a wire. The push button is a switch that closes a circuit and enables current to flow through a set of conductors and a buzzer.



The telegraph works on the same principle. An operator at one end of the line creates dots and dashes by pressing a key; this closes and opens the circuit. The flow of current energizes a sounder at the other end of the line; this reproduces the signals sent by the operator. Telegraphic signals can be sent wherever there are wires to carry the current.

## Magnetism

Electrical energy can be transferred from one conductor to another even though they are not connected to each other. This depends upon the fact that electricity and magnetism are closely related.

Ancient people knew of the existence of naturally magnetic substances such as lodestone, a form of iron ore. They discovered that a piece of lodestone would attract bits of iron and cause them to stick to it. Furthermore, as long as these pieces of iron were in contact with the lodestone, they would act as magnets and attract other bits of iron. As soon as contact was broken, they would lose their magnetic properties. It was also known that pieces of steel which were stroked with lodestone would become permanently magnetized.

We know considerably more about magnetism. In 1819 Hans Christian Oersted, a Danish physicist, discovered that every conductor carrying a current is surrounded by a magnetic field. If the conductor is formed into a coil, the strength of the magnetic field is concentrated. A piece of soft iron placed within such a field will become magnetized and will act as a magnet as long as current flows through the coil.

The existence of this magnetic force can be shown by constructing an electromagnet. This requires the use of a dry-cell battery. Make a coil by winding about 50 turns of insulated copper wire around a large iron nail. Connect one end of the wire to one of the battery terminals. Touch a small nail to the large nail and you will find that they are not attracted to each other. Now touch the other end of the wire to the other battery terminal, completing the circuit so that current flows through the coil. The large nail will immediately become magnetized and will attract the small nail. Break the electrical circuit and it will lose its magnetism. The magnetic force can be increased by adding turns to the coil, or by increasing the current flowing through the coil.

This experiment also shows that electrical energy can be converted to magnetic energy.

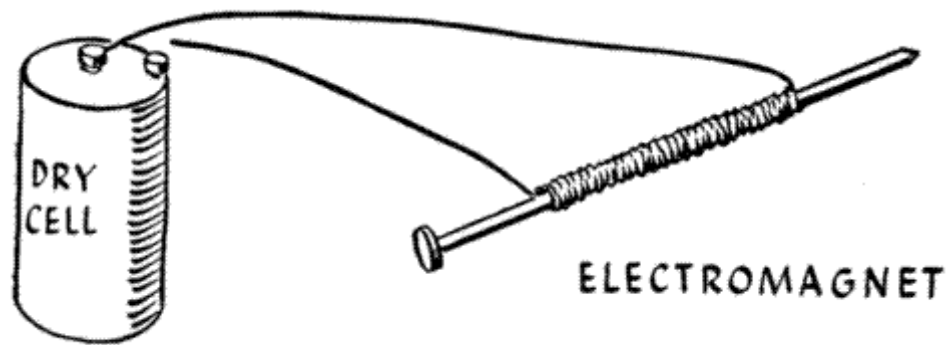

In 1831 Michael Faraday demonstrated that magnetism could be converted to electrical energy. He produced electrical current in a coil by moving a magnet through it. Strangely enough, no current flowed while the magnet was motionless. Faraday reasoned that the movement of the magnet or of the magnetic field surrounding it was in some way responsible for the current produced in the coil.

Faraday's conclusion was correct. The moving magnetic field cut across the coil, setting free electrons in motion and developing current. The moment the magnetic field stopped moving, current stopped flowing.

Faraday's experiment explains how electrical energy can be transferred from one conductor to another. We know that we can create a magnetic field around a coil by passing a current through the coil. If we place a second coil very close to the first one, the movement of the magnetic field around the first will develop electrical current in the second.

If you have a galvanometer (an instrument for measuring very small amounts of current) you can perform an interesting experiment that will demonstrate this idea very clearly.

Make a coil by winding about 50 turns of insulated wire around a pencil or wooden dowel; this is the primary coil. Wind another coil of approximately the same number of turns on top of the primary; this is the secondary coil. A device that transfers energy from the primary to the secondary coil is known as a transformer.

Attach the ends of the secondary coil to the galvanometer. Current flowing in this coil will be shown by a movement of the galvanometer needle. One end of the primary is attached to a 6-volt dry-cell battery, as shown in the illustration.



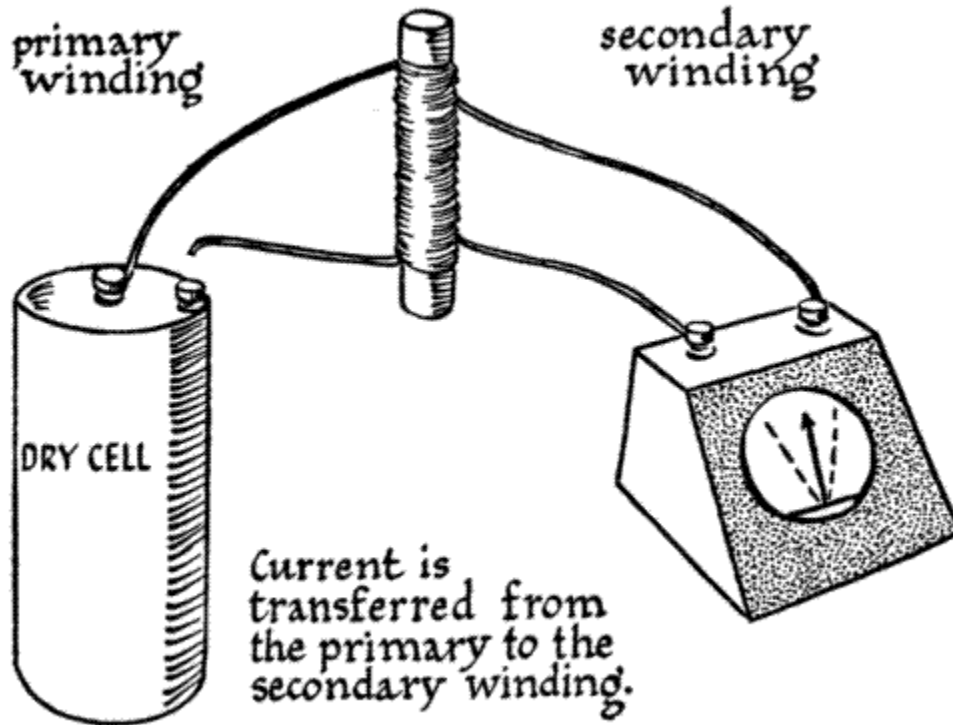

Make the connection so that current flows through the primary coil. The galvanometer needle will move, then return to zero. Release the connection, and the needle will once more move and return to zero.

Now let us analyze what has happened. As soon as current began to flow through the primary coil, a magnetic field built up around it. Magnetic lines of force cut across the secondary coil, developing a surge of current. Current stopped flowing in the secondary the moment the field reached full strength and became stationary. Releasing the connection stopped the current flow in the primary. The magnetic field began to collapse, again cutting across the secondary coil and inducing another surge of current.

Here is another experiment that you can perform to show how energy can be transferred from the primary to the secondary coils of a transformer.

You will need about 40 nails 1 1/2 or 2 inches long. Any iron nails will do. Stack them into a neat bundle, then wind about 100 turns of wire around them to make the primary coil. Fasten the last turn in place with a strip of adhesive tape. Make the secondary coil by winding the same number of turns directly over the primary coil. Scrape about one inch off the ends of the wires of both coils so that they are bright and clean.

You have just constructed a simple iron-core transformer. The nails form the iron core, which concentrates the magnetic lines of force and prevents them from leaking off.

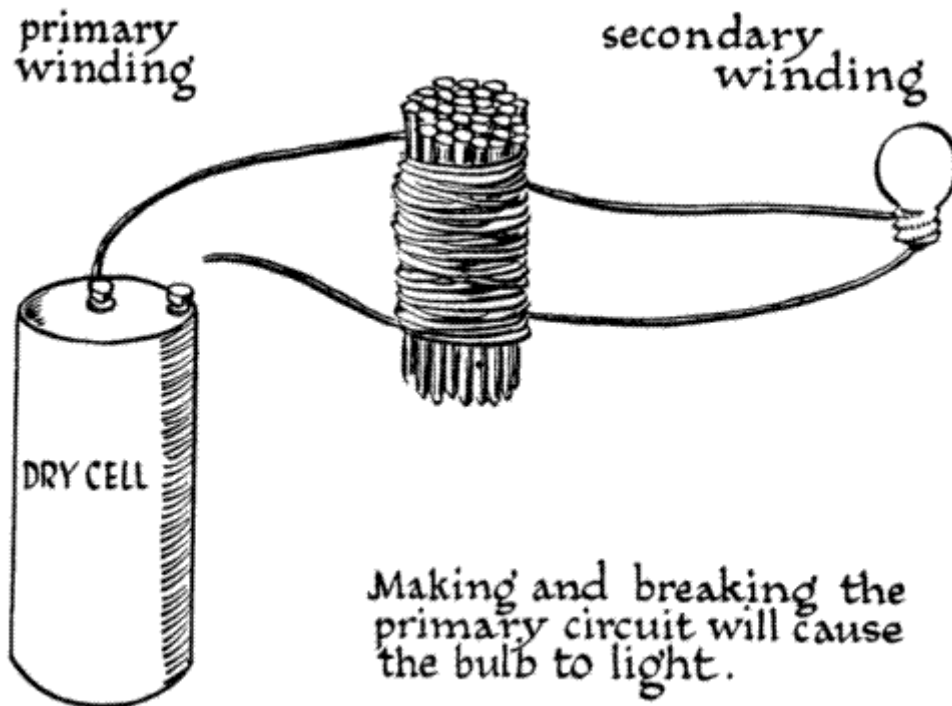

Hook up the primary circuit. Attach one end of the coil to one of the battery terminals; the other end should remain free, leaving the primary circuit open. A flashlight bulb takes the place of the galvanometer in the secondary circuit. Any bulb will do, but the type used with small penlight batteries is best, since it uses very little current.

Prepare the bulb by brightening all its metal surfaces with steel wool or with fine emery cloth or sandpaper. This will remove film and insure good electrical contact with the wires. One end of the secondary coil must make firm contact with the bottom of the bulb, and the other end with the side. It is a good idea to have someone assist you by holding the wires against the bulb.

Complete the circuit in the primary by touching the free end of the coil to the unused battery terminal. The bulb will flash, but will not remain lighted while the circuit is complete. Scratch the end of the coil against the terminal, and the bulb will show a brighter light. What you are actually doing is making and breaking the primary circuit very rapidly.

If we can keep the magnetic field in motion we will have a constant flow of current in the secondary coil. We have shown that this can be done by rapidly making and breaking the circuit in the primary coil, but the same result can be achieved in another manner. We have been using current supplied by a battery, which pushes electrons in only one direction; this is known as direct current. Certain types of generators can supply us with alternating current, which reverses its direction of flow periodically. Each complete reversal of current is known as a cycle. The frequency of a current is determined by the number of cycles that occur each second. Depending upon their specific use, alternating currents can be generated at almost any frequency. For example, house current is commonly supplied at 60 cycles; this represents 120 changes of current direction each second.

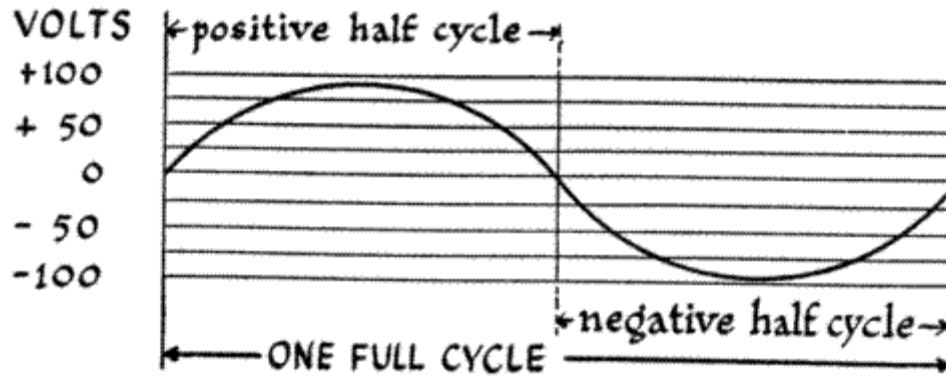

These changes of current direction may be shown as a series of wave forms. The horizontal line running through the center of the waves represents a point of zero voltage. Each complete cycle consists of a surge of positive current (shown above the line), and a surge of negative current (shown below the line). The positive half of the cycle starts at zero, builds up to a maximum voltage, drops back to zero, and immediately changes direction, becoming negative. The negative half cycle rises to its maximum, drops back to zero, and changes its direction, becoming positive.

Alternating current is in constant motion. When it flows through the primary coil of a transformer it creates a constantly moving magnetic field. Each time the current changes its direction, the field builds up and collapses, inducing a constant flow of current in the secondary.

## RADIO WAVES

Under certain conditions energy can be transferred from one conductor to another even though they are separated by hundreds of miles. This fact is responsible for the development of radio.

Two things are part of every radio system: a transmitter and a receiver.

The transmitter is a device that converts sound into electrical energy; this energy is broadcast through an antenna in the form of electromagnetic waves. Electromagnetic waves travel through space. Scientists do not fully understand how this takes place. Many theories have been evolved to explain this phenomenon, but none has proved completely satisfactory. Despite our lack of complete understanding of these waves, we have gained a tremendous amount of knowledge about them and are able to put them to use.

The action of electromagnetic waves has often been compared to the waves that are formed when a pebble is dropped into the water of a still pond. Waves radiate evenly on the surface of the water, gradually becoming smaller as they move away from the center of the disturbance.

The transmitting antenna radiates electromagnetic waves in much the same manner. They travel through space in all directions, gradually losing their strength as the distance increases.

Eventually some of these waves are intercepted by a receiving antenna. As they pass through the antenna, they set electrons in motion and cause a flow of current. For this reason an antenna must be a good conductor.

The current picked up by the antenna is fed into the receiver, which converts it back into sound. Through the marvels of electronics your radio receiver reproduces the identical sounds that are picked up by a microphone in the broadcasting studio.

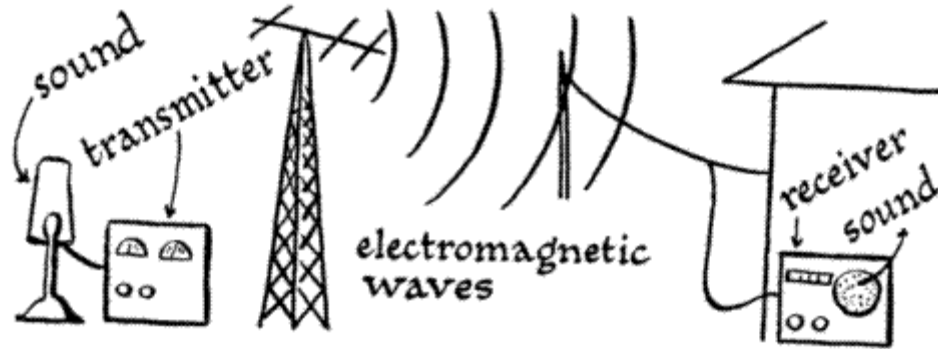

## BASIC PROCEDURES

Every craft requires the use of certain tools, and radio work is no exception. An elaborate workshop is not needed, but a few tools are essential. Good tools are a wise investment, so buy the best that you can afford. Never abuse tools by using them improperly. Keep them clean and dry. Should they show signs of rusting, they should be rubbed clean with fine emery cloth and coated lightly with machine oil. If possible, keep your tools in a rack or store them in a drawer when they are not in use.

### Pliers

Long-nosed pliers are used by all radio technicians. They are needed to hold wires and other parts that are being soldered and to bend wires into desired shapes. They should not be used for heavy work, such as tightening large nuts or bending nails and bolts. Think of this tool as an extension of your fingers that enables you to reach otherwise inaccessible places.

Diagonal cutting pliers are used to cut wires. There are many other types of cutting pliers, but they are mostly used for heavy-duty work. Diagonals have slim jaws and can be used in tight spots. Use them only on wire, never on nails or bolts, for the cutting edge can be nicked very easily.

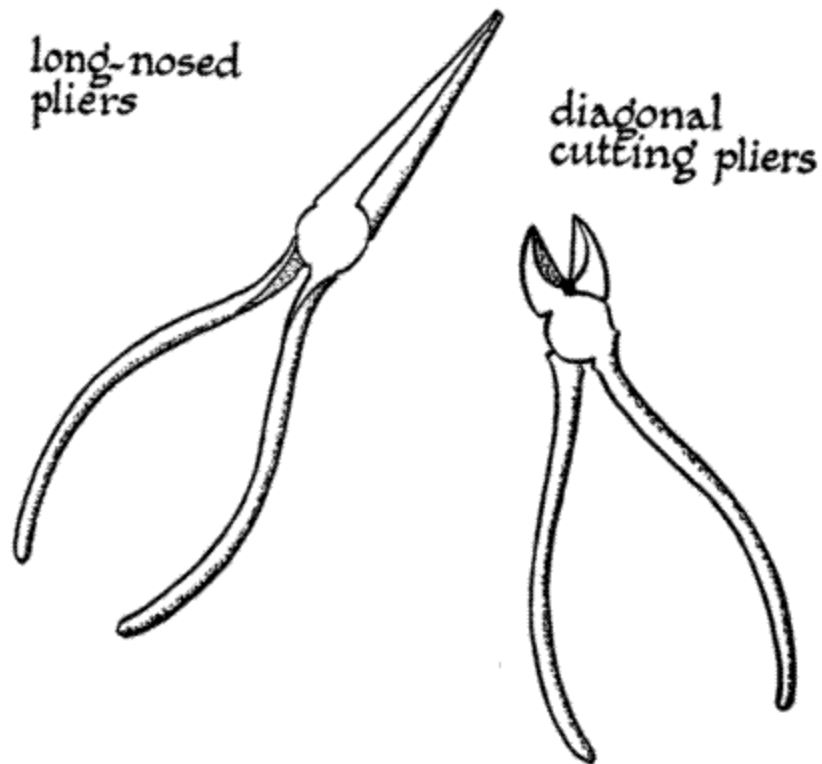

## Screwdrivers

Screwdrivers used in radio or electrical work should have insulated handles, usually made of plastic or hard rubber. They are made in several different sizes. The size you will need for a particular job will depend upon the size of the slot in the head of the screw or bolt that is to be tightened. The end of the screwdriver should just fit into the slot it engages. If it is too small it will mutilate the screw head, leaving sharp bits of protruding metal that can be quite hazardous. One that is too large will have to be forced into the screw slot, with the same results. The experiments in this book require the use of only one screwdriver; be sure it fits the screws you are using.



## Penknife

Wires and other parts that are to be soldered or are required to make good electrical contact are usually scraped. An old penknife makes an ideal scraper; it needn't have a sharp edge. Never use a razor blade for scraping. Not only is it a dangerous practice, but you may remove too much metal

from the wire, leaving it weakened.

## Socket Wrenches

Socket wrenches are used to tighten nuts. They may be purchased singly or in sets of assorted sizes. As the name implies, this tool consists of a socket, which is attached to a handle. The socket is slipped over the nut and the handle is turned like that of a screwdriver. Some sets consist of one handle with interchangeable sockets. You simply select the socket that fits the nut to be tightened, then fasten it to the handle by pressing it into place.

Socket wrenches are not essential, but they will make your work easier. If you do not have any, you can still tighten nuts and bolts very simply. Slip the nut over the bolt and turn it as far as you can with your fingers. Grasp the nut with a large pair of pliers, then use a screwdriver to turn the bolt the rest of the way.

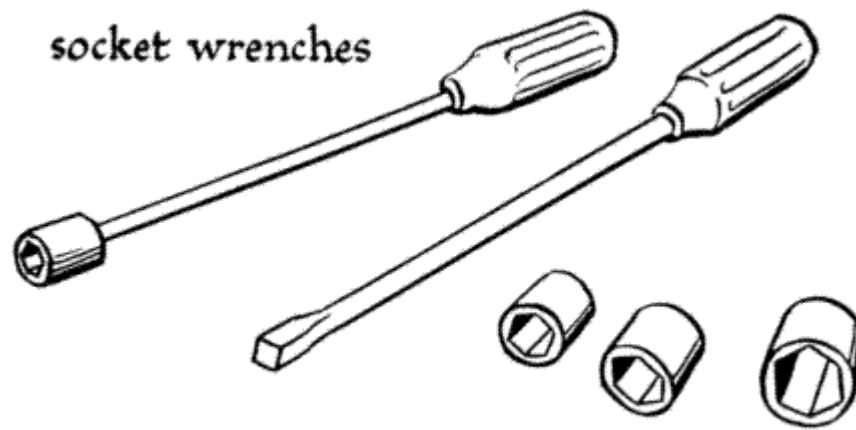

## HOW TO SOLDER

Solder is an alloy of lead and tin. It melts very readily and is used to fasten together wires and other metal radio parts. Do not attempt to do this with any type of cement, glue, or paste. These materials are insulators, and will prevent current from flowing through the joint you make.

Soldering requires the application of heat. In the old days people used a soldering copper, which was heated over a fire. When the copper became hot enough to melt solder, it was put to use. When it cooled it was reheated. Tinsmiths still use large soldering coppers, heating them with portable torches.

Radio men use electrically heated soldering irons. Although they are called "irons", they actually have copper tips. They are made in many different types and sizes and are rated according to their wattage, or electrical power needed to bring them to their operating temperature.

Very small electric irons are known as soldering pencils. These have fine tips and are excellent for delicate work. They consume very little power; a 15-watt pencil will do most soldering jobs. Many soldering pencils have interchangeable tips. When one wears out, it can be removed with a pair of pliers and a new one can be substituted. Some pencils consist of a handle into which heating units of different sizes can be screwed; these can be purchased separately.

Soldering is also done with an electric soldering gun. Such guns are usually made with a pistol grip so that they can be handled easily. Pressing a switch causes current to flow through a built-in transformer, and the gun is brought to operating temperature in a matter of seconds.

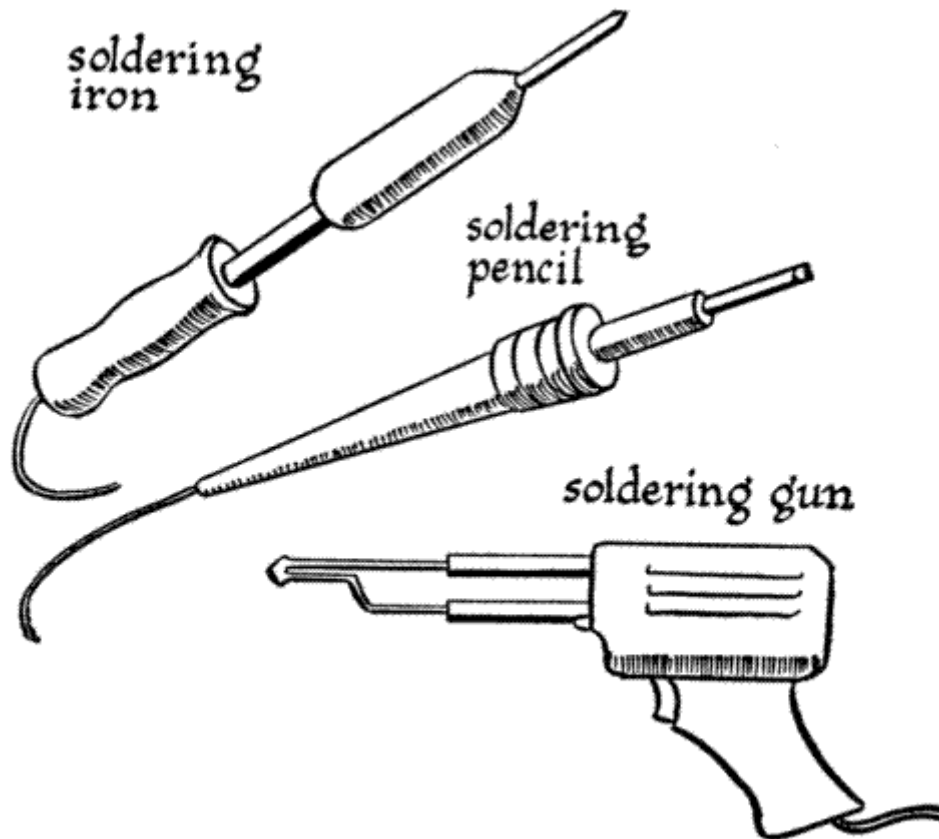

As soon as the joint is soldered, pressure on the switch is released and the gun is allowed to cool.

Not all metals can be soldered. Radio work usually calls for soldering copper or tinned surfaces, and this can be done very easily. Do not try to solder aluminum, as this cannot be done with ordinary soldering equipment; special types of solder must be used.

Solder is manufactured in different forms. Bar solder and solid wire solder are used by plumbers and tinsmiths. Neither one of these is suitable for our purpose. Rosin-core solder is the only type recommended for electrical connections. This is made in the form of a hollow wire, the inside of which contains rosin. The rosin serves an important purpose: it acts as a flux which keeps the joint clean as it is being soldered. The heat of the soldering iron causes metals to tarnish, or form an oxide very quickly. This coating or discoloration will prevent the solder from flowing and forming a good joint. Flux dissolves the oxides and makes soldering possible.

**Never** use acid-core solder. This is a type of hollow wire solder in which acid is used as a flux. It will enable you to make a good soldered joint, but the acid will eventually cause corrosion.

Soldering involves more than just applying heat. Follow these steps for good results:

(1) All surfaces that are to be soldered must be clean. Tarnish and dirt must be removed, otherwise the solder will not adhere. Brighten the metal by scraping it with a knife blade or rubbing it with sandpaper, emery cloth, or steel wool.

(2) Parts to be joined by soldering must make good contact. Wires should be twisted together. When soldering a wire to a larger surface, hold it in place with long-nosed pliers. Do not try to fill gaps between wires and other parts with solder.

(3) A new soldering iron must be tinned. This consists of coating the tip with a layer of melted solder. First, scrape or sandpaper the tip until it is clean and shiny. Plug in the iron and allow it to become hot enough to melt a bit of solder that is touched to it. Run melted solder all over the tip of

the iron, then wipe it on a clean rag; this will remove any excess solder, leaving a thin, even coating. After an iron has been tinned, it is simply heated each time it is to be used.

(4) Touch the hot, tinned iron to the joint that is to be soldered. Then bring the end of the wire solder into contact with both the iron and the joint. The solder will melt at once. Quickly remove the solder, but keep the hot iron in place for a moment; this allows the solder to flow around the joint. It also gives the flux a chance to boil off.

Never make a soldered joint by touching the solder only to the hot iron; this may result in a "cold" joint. The solder will melt but may not adhere properly to the metal parts that are to be joined.

(5) After you have removed the iron from the soldered joint, allow the solder to "set," or harden, before you touch or disturb it in any way. Use as little solder as possible. A joint that has been properly soldered has a bright, shiny appearance. If it looks dull or slightly rough, reheat it until the solder flows freely again.

Some radio parts have wire leads (pronounced leeds), or "pigtails" by means of which they are soldered into circuits. Excessive heat applied to these leads may be conducted to the part itself, causing damage. When soldering such parts, grip the wire lead with long-nosed pliers, just above the point you are soldering. Heat from the soldering iron will be absorbed by the plier tips, and will be prevented from passing along the wire to the part.

## WIRE

Wire is manufactured in different sizes, which are identified by gage numbers. The number of a wire refers to its diameter, or thickness; the higher the number, the thinner the wire.

Insulated wire is always used in radio construction. This is important, otherwise wires might touch at the wrong places and cause short circuits. Some commonly used insulating materials are rubber, plastic, and braided cotton covering.

Most people use hookup wire for circuit wiring. This wire may consist of a single, solid wire or it may be made up of separate wire strands twisted together. Stranded wire is more flexible and can be twisted and bent many times before breaking. On the other hand, solid-conductor wire is less expensive and easier to handle. Hook up wire is always tinned, and it need not be scraped before it can be soldered. The end of an insulated wire must be bared before it is fastened in place in a circuit. Use your penknife to cut lightly through the insulation all around the wire. Hold the blade at an angle, so that the sharp edge faces the end of the wire. If you hold the knife blade at a right angle to the wire, you may cut through the insulation and nick the wire: this will cause it to break the first time it is bent. Using diagonal pliers, grasp the insulation below the point you have cut, then pull it free.

The easiest type of hookup wire to use is push-back wire. No cutting is necessary. In order to bare the end of the wire, simply push the insulation back with your fingers.

Magnet wire is used for winding coils. It may be purchased in spools weighing 1/2 pound or 1 pound. Sizes 24 to 32 magnet wire may be used for all the experiments described in this book. You can also use it instead of hookup wire in constructing our low-powered circuits.

Magnet wire is usually insulated with enamel or plastic coating or cotton wrapping. Coated wires take up less winding space than wrapped wires and make smaller coils. A penknife, sandpaper, emery cloth, or coarse steel wool can be used to remove coated insulation from wire.



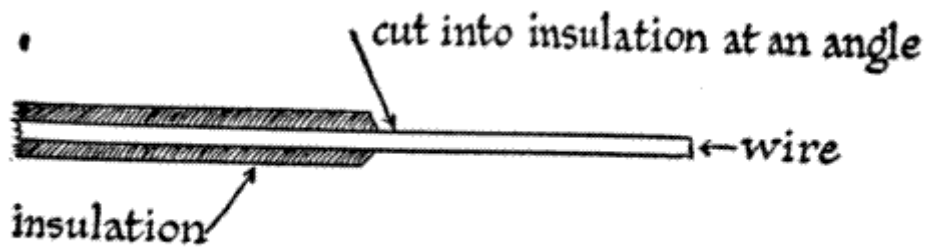

### Chapter 3 ANTENNAS AND GROUNDS

An antenna, or aerial, is a conductor that intercepts broadcast electromagnetic waves. Every radio receiver must have an antenna. Commercially built receivers usually have small loop or coil antennas concealed within the cabinet.

A good antenna will improve the performance of any radio. This is particularly true of the low-powered receivers we are going to build. Any substance that is a good conductor will make a good antenna. The simplest antenna is a long length of wire connected to the receiver. Although any wire can be used, most antennas are made of stranded copper wire. Your antenna should be erected as high as possible and kept away from power lines and from touching trees, buildings, or tin roofs. The longer it is, the more efficient it will be. If possible, make your antenna at least 100 feet long. If that is not feasible, a shorter wire (at least 25 feet long) will have to do.

Antenna wire may be bare or insulated. Fasten each end of the antenna wire to a porcelain insulator. Pass the wire twice through one of the ends in the insulator, then wind it back on the antenna itself, using at least 10 turns. Suspend the antenna between your building and an other building, a tree, or post. This can be done by running a wire from the free end of each insulator to a firmly anchored screw eye or screw hook, as shown in the illustration.

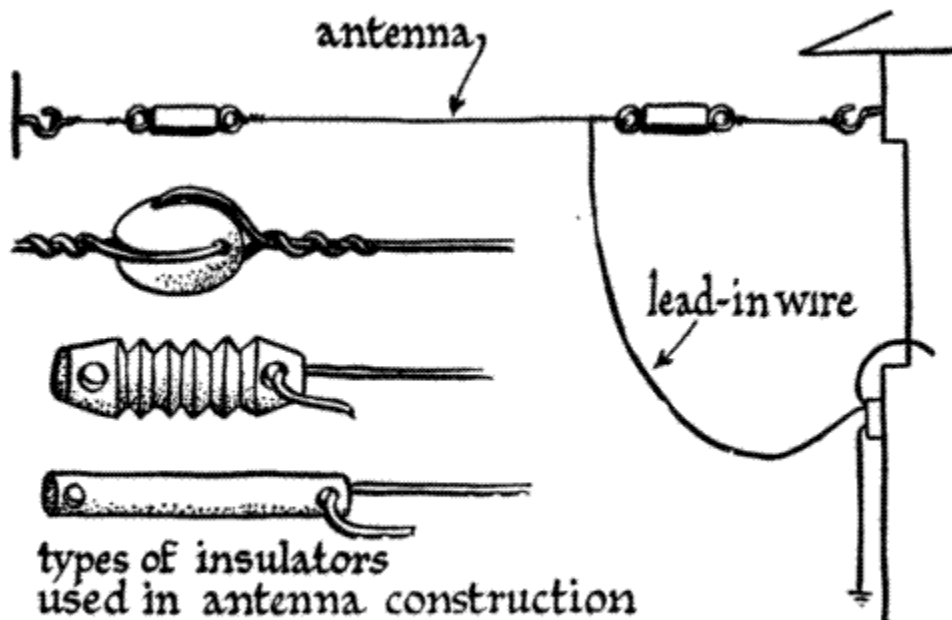

The end of the antenna near your house should be connected to a lead-in wire, which then goes to the antenna terminal of your receiver. Make the connection by scraping both ends, then twisting them

tightly together. A few turns of electrician's tape over the joint will prevent it from weathering. Any insulated wire makes a good lead. The illustration shows a typical long-wire antenna system which makes use of a device known as a lightning arrester. This arrester protects the receiver in case the antenna is struck by lightning, and it should be part of every outdoor antenna installation. It will sidetrack a discharge of lightning directly to ground instead of permitting it to reach the receiver.

The arrester has two terminals. The lead-in wire is connected to one of them, from which it goes directly to the receiver. Another length of wire is connected to the other terminal; the other end of this wire is clamped to a ground rod. This is a copper-plated steel rod from four to eight feet long that is driven into the ground next to the building. Ground rod and clamp sets are sold by radio supply stores.

Any type of metal pipe four to eight feet long driven into the ground makes a satisfactory ground rod. The ground wire can be fastened to it with a ground clamp which may be bought at any electrical supply store.

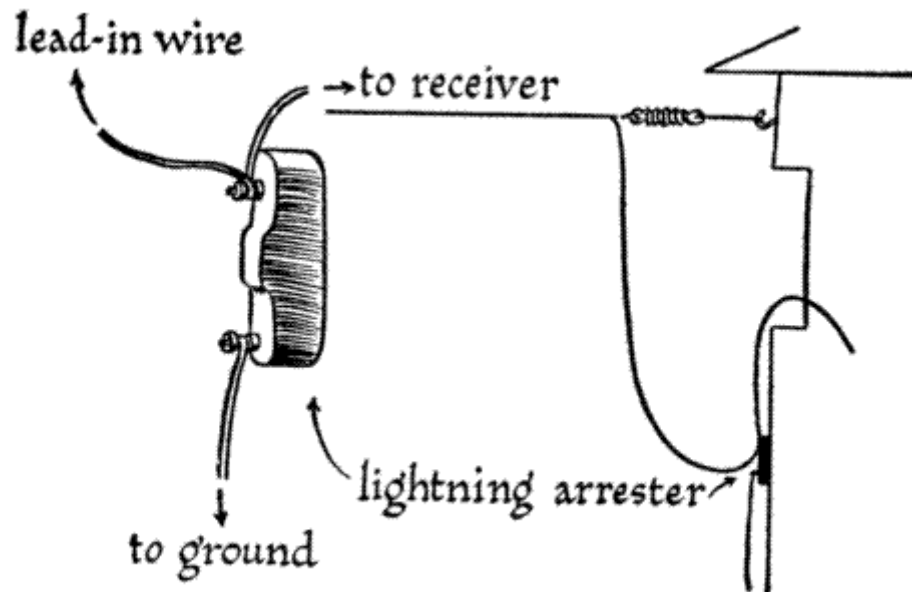

Many experimenters, particularly those who live in apartment houses, cannot erect an outside antenna. In this case one can be improvised by connecting a wire to a metal window screen, a bedspring, or any other large metal object that is not in contact with the ground. Reception can often be improved by using just a few feet of wire as an antenna. A short length of wire can even be dangled from a window in order to get it out of the way. Make a hidden indoor antenna by tacking a length of wire on top of the picture molding in your room. Or, try running some fine magnet wire around the baseboard; it is so thin as to be practically invisible.

A ground is a connection made to the earth, either directly or indirectly. Most of the receivers described in this book require ground connections. The best ground is made by attaching a wire to a cold water pipe. Scrape a small section of pipe until all paint is removed and the metal is bared. Pass a few turns of wire around the clean area and twist it tight. A ground can also be made by driving a metal rod or pipe into the earth; it should be at least 3 or 4 feet long.

If you cannot hook up to either a cold-water pipe or an outside ground, try attaching a wire to a radiator pipe. This is definitely a second choice, to be used only when a proper ground connection is not available.

## Chapter 4 RADIO COMPONENTS

Many different parts are used in radio construction. In order to build a piece of electronic equipment it is necessary to know exactly where each part fits into the circuit.

### **Circuit Diagram**

This information can be found in a circuit diagram, which is actually a radio construction plan. Instead of being represented by pictures, parts are shown as symbols. Symbols have been standardized so that they have the same meaning for everyone.

All wires in circuit diagrams are shown as lines. A wire connection is indicated by a heavy dot where lines meet or cross. If no connection is to be made at that point, one line is drawn looped over the other. This system is used in all the circuits shown in this book. In other types of circuit diagrams connections may be shown by lines that meet or cross; no dots are used.

### SYMBOLS

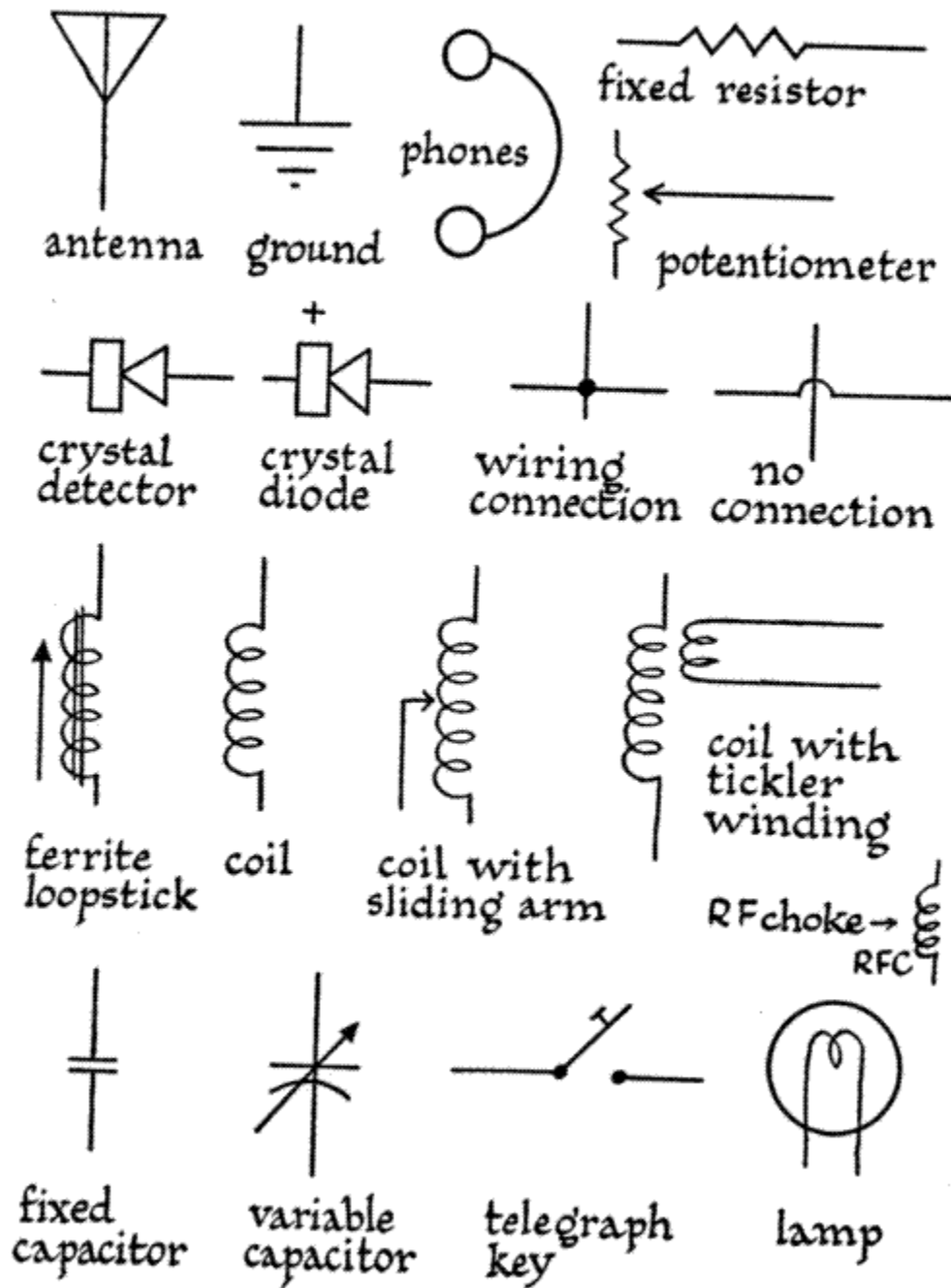

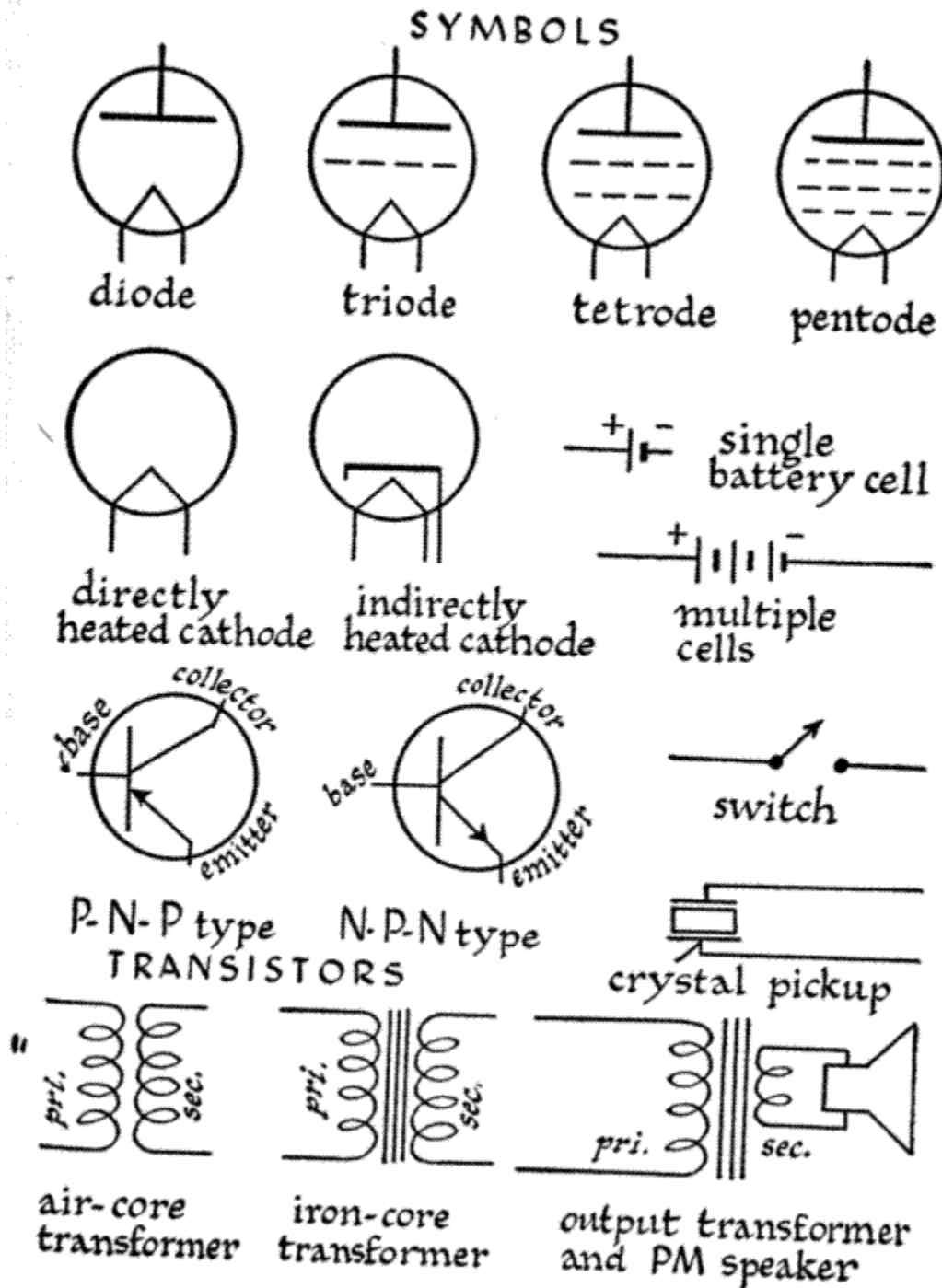

## Capacitors

Capacitors (also known as condensers) are devices that can store an electrical charge. When used in an electronic circuit, a capacitor will charge and discharge current at the same frequency as the current that is applied to it. The amount of current it can handle depends upon its capacity, or capacitance. It will not pass direct current although it will permit the flow of alternating current.

Capacitors are rated in units called farads. Since a farad is much too large for use in radio circuits,

capacitance is usually measured in smaller units. A microfarad (abbreviated  $\mu\text{F}$  is one-millionth of a farad; a micro- microfarad (abbreviated  $\mu\mu\text{F}$ ) is one-millionth of a micro farad.

Both fixed and variable capacitors are used in radio work. Values of fixed capacitors are either marked on each piece or are shown by color-coded dots. Since there are several different color codes, a confusing situation exists. It is recommended that beginners buy capacitors on which values are clearly shown. Any type of fixed capacitor may be used to construct the circuits described in this book.

Variable capacitors are used in tuning circuits. They contain two sets of metal plates; one set is fixed and the other is movable. Turning the plates varies the capacitance of the unit. This makes it possible to receive stations at different frequencies. You will need only one capacitor in order to construct the projects in this book; it should be rated at about 365  $\mu\text{F}$ .

## Resistors

Every conductor offers some opposition or resistance to a flow of current. Copper wire used in radio circuits permits current to flow readily and for our purposes is considered as having no important resistance.

Insulators permit no current to flow through them and are used to block the flow of current completely. Other substances permit a partial flow of current; they may be thought of as partial conductors. Depending upon their composition, they can be made with a specific degree of resistance, so that a certain amount of current will flow through. These are known as resistors. They are used to restrict the flow of current in circuits.

The unit of resistance is an ohm, shown by the Greek letter omega ( $\Omega$ ). One ohm is written as  $1\Omega$ . One thousand ohms can be shown as either  $1000\Omega$  or as  $1\text{K}$  (K is the symbol for 1000). Thus  $15,000\Omega$  and  $15\text{K}$  represent the same value of resistance. One megohm (commonly called a meg and abbreviated as  $1\text{M}$ ) is equal to 1 million ohms.

The more resistance a circuit contains, the less current it will pass. It is therefore important to use resistors of the same value as those specified in the circuit you are following. However, the circuits in this book can be constructed by using resistors of approximately the same value as those indicated. Variations of 25 per cent in resistor values will not affect their performance. Very few resistors are marked with numerical values; most are color coded. The code consists of bands of color encircling the resistor. Each color represents a digit. If you memorize the color code, you will be able to identify resistor values at once.

In order to determine the value of a resistor hold it as shown in the illustration and refer to the table here.

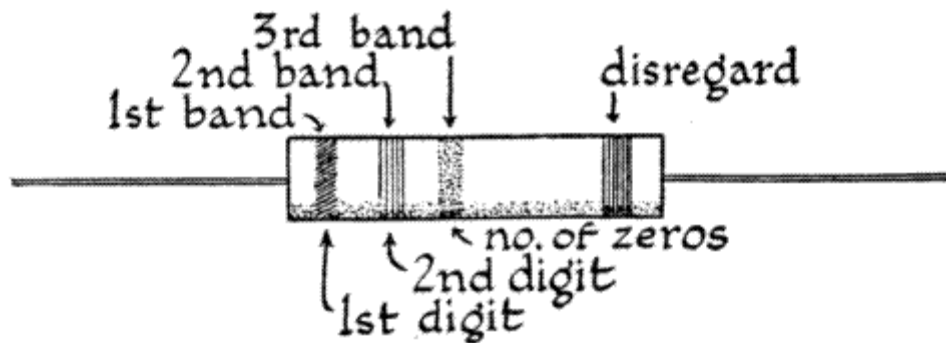

<i>Color</i>	<i>First Band (1st digit)</i>	<i>Second Band (2nd digit)</i>	<i>Third Band (No. of zeros added)</i>
Black	0	0	0
Brown	1	1	1
Red	2	2	2
Orange	3	3	3
Yellow	4	4	4
Green	5	5	5
Blue	6	6	6
Violet	7	7	..
Gray	8	8	..
White	9	9	..

Consider only the first three bands marked on the resistor; disregard the fourth. Let us assume that the resistor we wish to identify is coded as follows: first band, red; second band, green; third band, orange.

According to the table, red has a value of 2, which is the first digit of the resistor value. The second band is green, so the second digit is 5. The third band, orange, shows that three zeros must be added to the two digits we already have; this gives us 25,000.

Here are some other resistor color combinations you can check just for practice:

Brown, orange, yellow: 130,000

Yellow, blue, orange: 46,000

Brown, black, green: 1,000,000, or 1 meg

Orange, green, green: 3,500,000, or 3.5 meg

### Potentiometer

A potentiometer is a variable resistor. The amount of resistance in the circuit is changed by turning

a control shaft, which moves a sliding arm along a resistance element. Potentiometers, often called pots, are used mostly as volume controls.

## Transistors

Most of the circuits in this book make use of transistors. Transistors serve the same purpose as vacuum tubes and have several characteristics that make them ideal for our experiments. They are more efficient than tubes, considerably smaller, less expensive, and they will last indefinitely. Furthermore, they consume practically no current, and the batteries you use will last a long time.

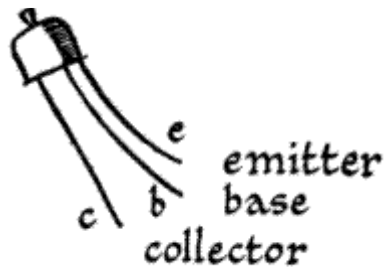

Transistors have three leads which are identified in the illustration as c (collector), b (base), and e (emitter). Notice the unequal spacing of the leads; the collector is always the one that is farthest away from the other two.

There are two types of transistors: P-N-P and N-P-N. You can tell which type is indicated on a circuit diagram by carefully observing the arrowhead that represents the emitter. In a P-N-P transistor, the arrowhead points toward the inside of the symbol. In the N-P-N type it points toward the outside. Do not use these types interchangeably. Their elements are connected to the plus and minus battery terminals in different ways. Even a momentary surge of current flowing in the wrong direction can ruin a transistor.

## Batteries

The symbol for a single dry cell is two vertical lines. The short line represents the negative terminal, and the long line the positive. The actual voltage used in a circuit can be shown by symbol if it is not too great. Since each cell delivers 1 1/2 volts, a power supply consisting of 6 volts would be indicated by four cell symbols. However, it would be impractical to show a 45-volt or 90-volt power supply in this way. For this reason, battery power supplies are generally shown by drawing the symbol for two or three cells; the actual voltage needed is marked on the circuit diagram.

## Detector

The detector, or rectifier, is an important part of every radio receiver. In order to understand what a detector does we must first consider what happens at the broadcasting studio. When speech or music is picked up by a microphone, varying alternating currents are generated up to about 15,000 cycles per second; these are known as audio frequencies (abbreviated AF). These frequencies are too low to be broadcast directly.



Frequencies of more than 20,000 cycles per second are known as radio frequencies, or RF; high-frequency RF currents can be broadcast easily. The transmitter at the broadcasting station generates a steady RF current, or carrier. The exact frequency generated depends upon the frequency at which the station is broadcasting. Stations in the broadcast band operate between 550,000 and 1,650,000 cycles per second. For convenience, we shorten these numbers by referring to them as 550 and 1,650 kilocycles; a kilocycle is equal to 1,000 cycles.

The audio and carrier signals are now mixed. The carrier no longer consists of a steady RF current but has the varying audio signal impressed upon it. It is now known as a modulated carrier. This is the electromagnetic wave that is sent out by the broadcasting station. The modulated carrier is picked up by the antenna of your radio receiver. A tuning circuit separates the desired signal from others, so that it is heard without interference. Now the detector goes to work: it separates the audio from the carrier. The carrier is by-passed, or shunted to one side; it is no longer needed. The audio is amplified and sent along to the headphones or loud speaker, from which it emerges the same as the one that was picked up by the microphone at the studio.

The separation process is known as detection, or demodulation; and the device that does this job is the detector. Detectors used in the receivers we shall build are made of a substance known as a semiconductor. A semiconductor permits current to pass through it very easily in one direction but offers high resistance to current flowing in the other direction. It acts as a one-way gate, which transforms alternating current into a form of direct current. (Alternating current reverses its direction periodically, while direct current flows in only one direction).

There are two types of detectors that we can use. One, a type that has been in use for many years, uses a chunk of galena, a lead ore. This is mounted in a holder. A fine wire "cat's whisker" comprises the other part of the detector. The whisker is touched to different places on the surface of the galena. Some spots are more sensitive than others; it is allowed to rest at that point which produces the loudest signal.

Cat's-whisker detectors are not very satisfactory. The slightest movement will disturb the setting of the wire, and a sensitive spot will once again have to be found. Dirt will impair the sensitivity of the galena, and you will have to be careful not to touch its surface. A fingerprint can leave a film of oil which may put you out of business.

The best type of detector to use is a crystal diode. This is a sealed unit that contains a bit of germanium. It also has a cat's whisker, which is permanently fixed in place so that no tuning is necessary. All you need do is hook the diode into a circuit and it will work automatically. One end of each diode is marked with a K, a band, or a large dot which indicates the positive or cathode side.

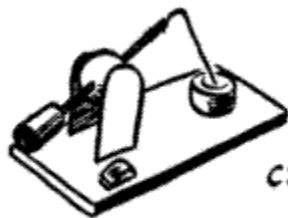

*cat's whisker crystal detector*

In some circuits the manner in which the diode is connected does not affect its efficiency. In others, reversing the diode connections will improve reception.

## Headphones

Headphones are used by all electronics experimenters. They are more sensitive than loudspeakers and will enable you to hear very weak signals. There are several types of headphones on the market. The most familiar is the one that has two earpieces, connected by a band that slips over your head.

There are also single-ear units. These may be the type that fit over your ear, or they may resemble hearing-aid earpieces which fit into your ear.

Some phones make use of crystals as receiving units. These will not work in our transistor circuits. Use only magnetic phones.

Impedance is opposition to the flow of alternating current, and is expressed in ohms. The best headphones to use are those that have an impedance of at least 2,000 ohms. These are known as high-impedance phones. The higher the impedance, the more sensitive the phones will

## Chaper 5 CONSTRUCTION HINTS

All projects in this book are assembled on a base. The simplest base is a piece of soft pine about 1 inch thick, 8 inches wide, and 12 inches long. These dimensions are approximate and need not be followed exactly.

Circuits can be assembled with little or no soldering by fastening all wires to terminals, which can be made of 5/8-inch or 3/4-inch round-headed wood screws and washers.

To make a terminal, slip a screw through a washer, then turn it part way into the wooden base. The hole in the washer must be smaller than the head of the screw. In order to fasten two or more wires to a terminal, wrap them once around the screw, under the washer. Turn the screw down to make firm contact against the base.

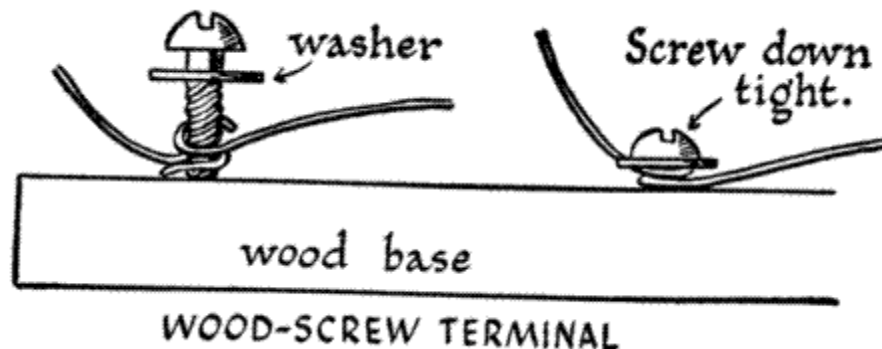

Bases can also be made of either hard Masonite or 1/4-inch plywood. Since both of these materials are too hard to take screws readily, a hole must be drilled where ever a terminal is to be placed, and a small machine screw is passed through the hole. Machine screws used as terminals should be 1/2 inch long; you should also have two hexagonal, or hex, nuts to fit each screw. For example, if you are using 1/2-inch x 5-40 machine screws, you must match them with 5-40 hex nuts. Number 5 refers to the thickness of the screw; 40 indicates the number of threads per inch.

To make a machine-screw terminal, first drill a 3/16-inch hole through the base; this will permit a No. 5 screw to go through. Push a screw through the hole from the bottom and thread a nut on it from the other side of the base; tighten the nut. Wires are wrapped once around the screw, after which a second nut is tightened down to hold them firm. Machine-screw terminals are best.

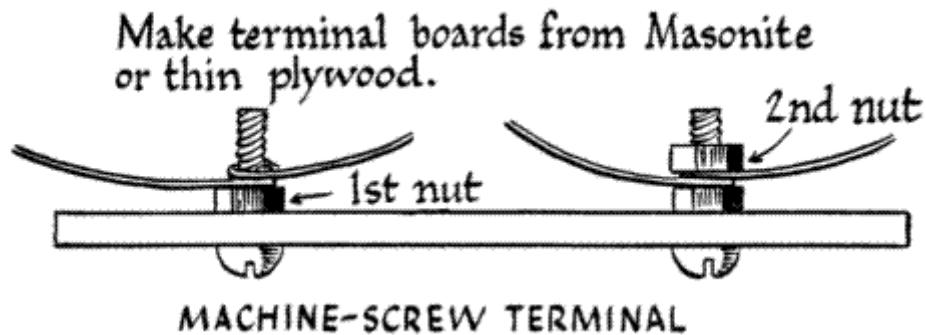

You can save yourself the chore of drilling holes by using a piece of Masonite that comes with holes already drilled in it. This perforated Masonite can be purchased at lumber yards and hardware stores.

Circuit construction can be simplified to a great degree if you are willing to do some preparatory work. Parts with wire leads can be fastened to terminals very quickly and easily if they are first soldered to soldering lugs. Then, instead of wrapping a wire lead around a terminal, simply place the lug over it. Lugs are made of tinned sheet brass and are inexpensive. Remember to grip all wire leads with long-nosed pliers when soldering them to lugs; this will prevent delicate parts from becoming damaged.

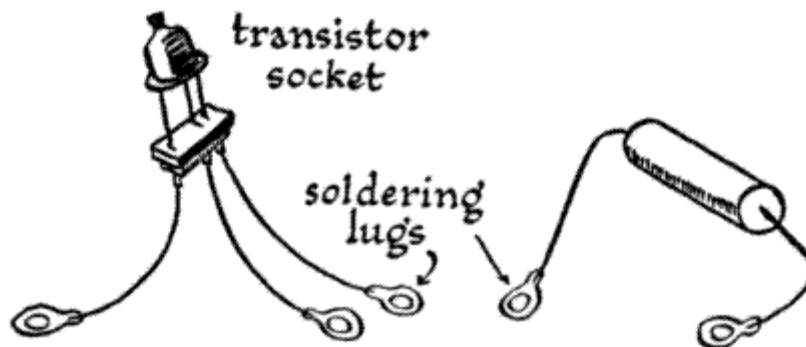

Transistors are particularly sensitive to excessive heat. Do not solder lugs to transistor leads. The safest way to fasten them into a circuit directly is by wrapping them around terminals.

The best way to install transistors is by using special sockets, as illustrated. The transistor leads are plugged in, making tight contact. Solder a 3-inch length of wire to each socket connection, then solder lugs to the ends of the wires.

Regardless of its size, a single dry cell will deliver 1 1/2 volts. A large cell can furnish more current than a small one, but that is the only difference between them; their voltage output is the same. Ordinary flashlight battery cells can be used to supply power for transistor circuits. They can be connected in series, in which case their total voltage is the sum of the voltages of all the cells used. For example, two series-connected cells will furnish 3 volts; four cells will supply 6 volts, etc.

To connect two cells in series, first fasten them together with a couple of rubber bands or wrap them with cellulose tape. Solder a long lead to the positive terminal of the first battery; this represents +3 volts. Solder one end of a short wire to the bottom (negative terminal) of the same battery, and the other end to the positive terminal of the second battery. Another long wire soldered to the bottom of the second battery represents -3 volts.

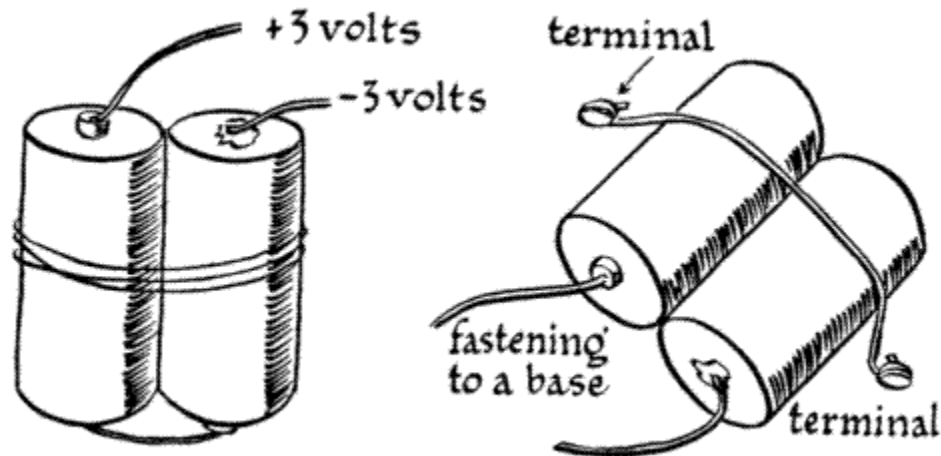

Any number of cells may be connected in the same way; join the positive of one to the negative of the next, and so on. Manufacturers stack small cells to make batteries capable of delivering high voltage. A 45-volt battery contains 30 cells; batteries with outputs of 67 1/2 and 90 volts contain 45 and 60 cells each.

Assemblies of flashlight cells should be strapped to the base by attaching a piece of wire to terminals on both sides, as illustrated. These are not electrical connections; the terminals are simply used as anchor points for the wire strap.

All large or heavy parts should be secured to the base. In order to mount the variable capacitor you will need a small piece of sheet metal about 1 inch wide and 2 inches longer than the capacitor. The bottom of the capacitor has two threaded holes which usually take 6-32 machine screws. Do not use screws more than 1/4 inch long or they may interfere with the movement of the capacitor plates. Drill a 3/16-inch hole near each projecting end of the metal strip and use either wood screws or machine screws to fasten it to the base. The illustration shows how variable capacitors are wired into circuits, and also how they are mounted. The movable plates of a variable capacitor are always connected, or grounded, to the frame. Since the frame is fastened to the metal plate, all capacitor ground connections are made to the plate. Connections to the stationary plates are made to a small lug on the side of the capacitor.

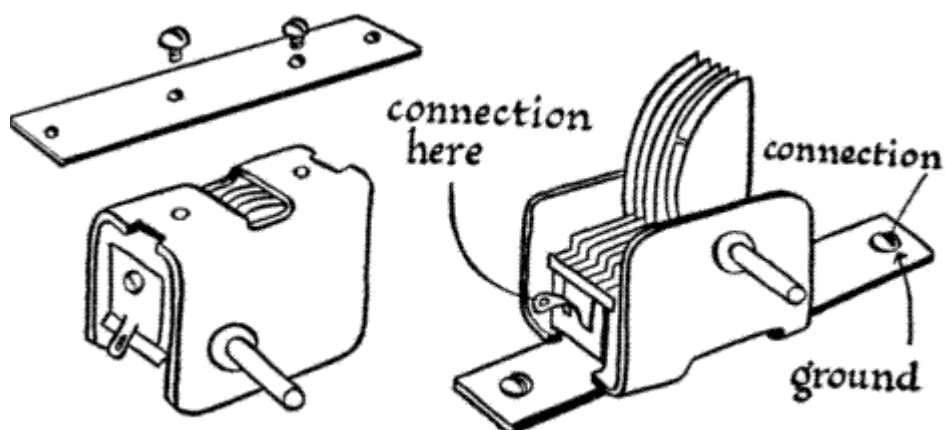

Coils consist of turns of wire. Any size magnet wire between No. 24 and No. 32 will do for the projects in this book. It may have either coated or wrapped insulation. Coils with primary and secondary windings are called transformers. Doorbell transformers and output transformers are wound around laminated iron cores, and are known as iron-core transformers. The iron core of a transformer is shown on circuit diagrams by vertical lines between the primary and secondary windings. The

primary is usually on the left side of the symbol, and the secondary is on the right. If the position of the symbol is changed, the primary and secondary will be clearly marked. Both doorbell and output transformers have perforated feet, so that they can be mounted on a base with screws.

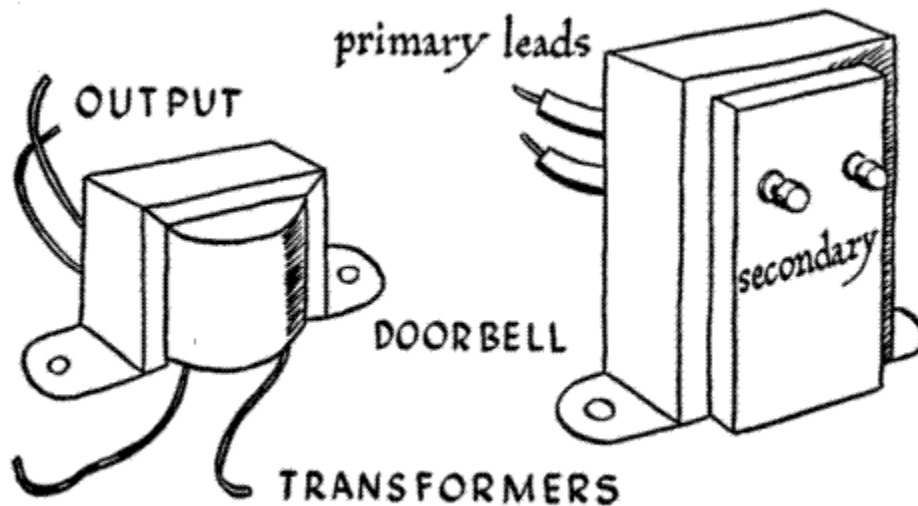

In order to wind a coil you must have a form. Suitable forms can be found very easily. The hollow cardboard cores from either toilet tissue or paper towels make excellent coil forms. You can make a better coil by winding it around a piece of wood about 1 inch thick, 2 inches wide, and 5 inches long; this coil will be used in most of the receivers described in this book. The first step is to give the form a coating of Duco cement. This applies to both cardboard and wooden forms. The cement prevents them from absorbing moisture and also serves as insulation. When the cement has dried thoroughly you are ready to start the windings.

Make the first winding 1 inch from the end of the form, and anchor it in place with a strip of adhesive or cellulose tape. Wind about 3 inches of coil, leaving 1 inch of the form exposed; anchor the last turn in place. Leave about 12 inches of wire at each end of the coil, and solder each to a lug. Windings must be tight and close together.

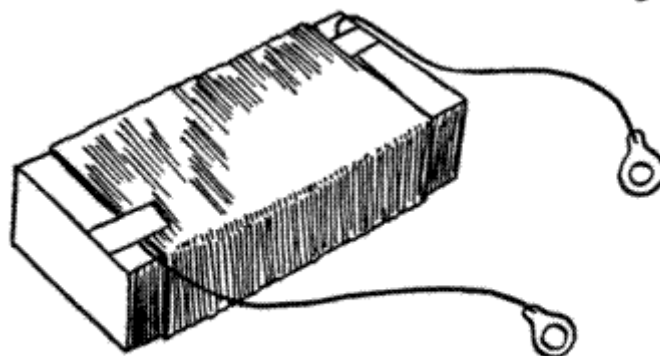

To mount a cardboard-core coil, bore a hole near each end of the form where it will not interfere with the windings. The coil can be fastened to a wooden base with Wood screws. If the holes are made to coincide with those in perforated Masonite, the form can be mounted with machine screws.

Wooden coil forms can be mounted in two ways. Drill holes through each end of the form and fasten it to your wooden base with long wood screws. Or, make simple brackets of thin sheet metal, as

shown in the illustration. Screw one side of each bracket to the end of the form, and the other side to the wooden base. Make the brackets long enough to enable you to fasten them to perforated Masonite.

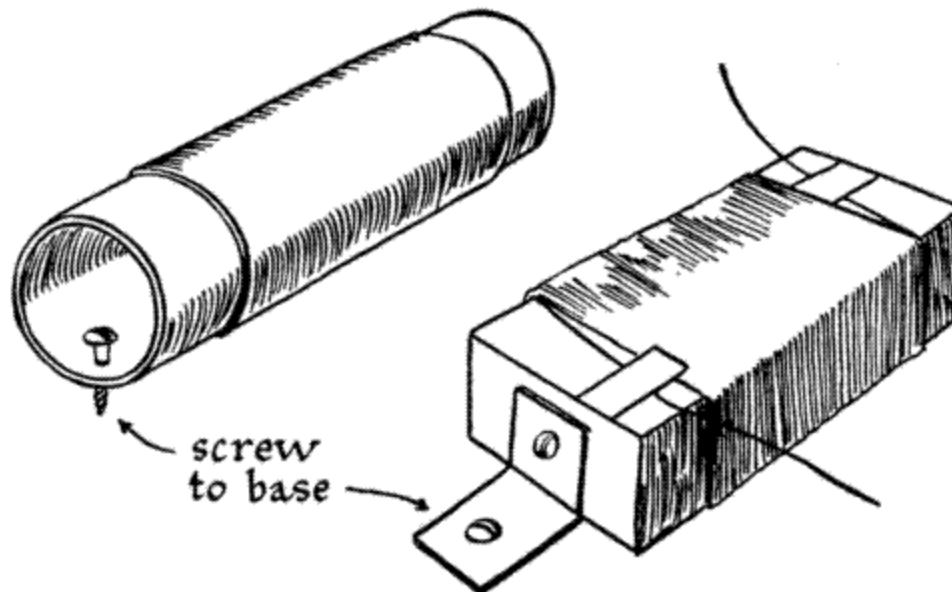

A ferrite loopstick is a commercially made coil which is used in some of the circuits in this book. It is very sensitive, and very selective when used in a tuned circuit. This coil is not tapped by a sliding arm, as is the wound coil. Instead, it is tuned by varying the position of the ferrite slug (a mineral composition), around which the coil is wound. The coil windings are brought to two terminals. A short wire antenna may be attached to one of them, in which case the other terminal is connected to ground. The wire antenna may be removed, and either connection used as antenna or ground; it makes no difference. Loopsticks are usually furnished with small mounting brackets, together with instructions for installation.

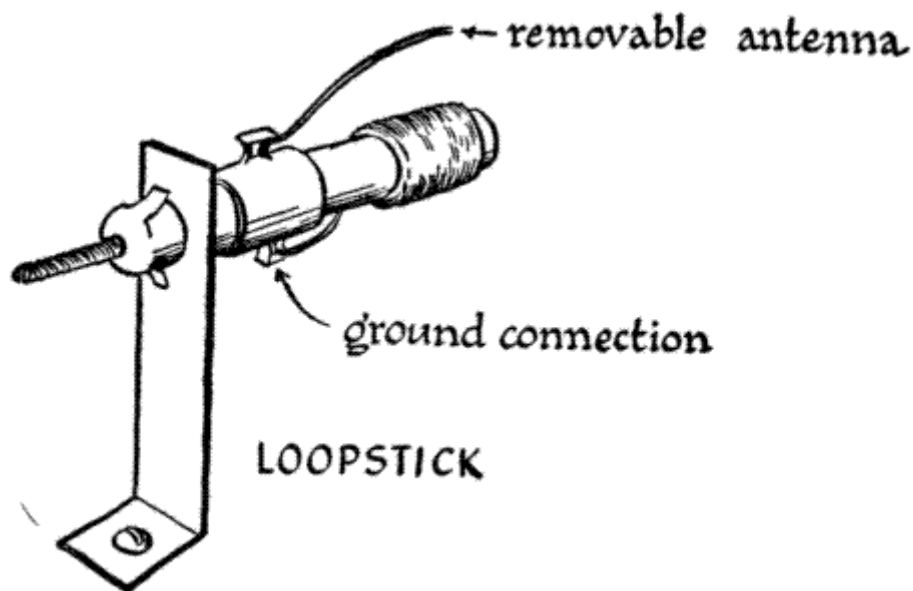

Vacuum-tube sockets should be firmly mounted to the base. When using perforated Masonite or thin plywood, insert two long machine screws from the bottom. Fasten these in place with a hex nut. Screw a second nut to each screw, about 1/4 inch from the top, as illustrated. The screws must be the same distance apart as the mounting holes in the socket so the socket can be slipped over them. The

socket rests on the two hex nuts; a third set of nuts holds it in place.

Potentiometers should be mounted firmly, too. Make a bracket from a piece of wire coat hanger, as shown in the illustration.

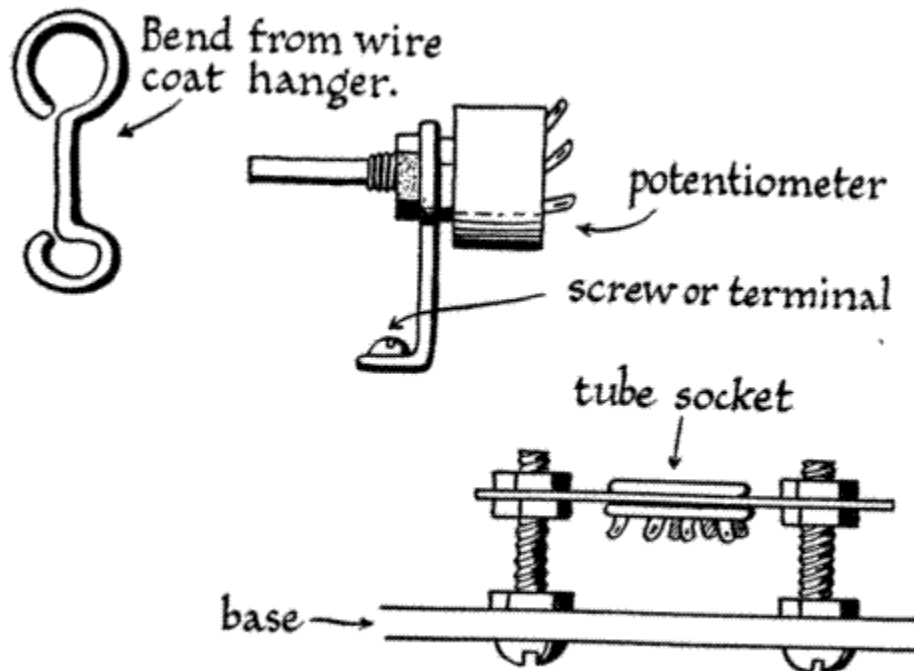

The operation of a loudspeaker depends upon the fluctuation of a magnetic field. There are two types of speakers: electrodynamic and permanent magnet. Do not attempt to use an electrodynamic speaker. In the first place, a large supply voltage is required to create the magnetic field needed to operate it; this is impractical. The permanent-magnet type (abbreviated PM) has a powerful alnico magnet built into it. A magnetic field is always present, and high voltage is not needed to energize it. To tell whether your speaker is a dynamic or PM type, hold a screwdriver against the center of its back. If it is a PM speaker, the screwdriver will be strongly attracted to the magnet. An electrodynamic speaker will not attract metal.

Most modern radios use permanent-magnet speakers. They are inexpensive and can be purchased locally at almost all radio shops. If you have a small radio that is no longer needed at home, you can "cannibalize" it by removing parts you need to construct circuits. Almost any speaker can be used, provided it has not been mutilated.

An output transformer is a device that matches the output of an electronic circuit to a loudspeaker. In small radios the output transformer is usually mounted on the speaker frame. Do not try to remove it, or you may damage the speaker. Loudspeakers must be handled with care, as their paper cones are quite delicate and can be punctured easily.

You will find four wire leads coming from the output transformer. Two of these are soldered to terminals on the loudspeaker. These are the secondary transformer leads, which are attached to the voice coil, a coil of very fine wire positioned around the magnetic core of the speaker. Electrical energy causes the magnetic field in the voice coil to fluctuate; this makes it move. The movement of the voice coil is transmitted to the entire cone, producing sound. Do not disconnect these leads. The two leads coming from the other side of the output transformer are the primary leads. One is soldered to a tube socket and the other to the power supply of the radio. Both of these leads can be cut at these points, leaving as much wire as possible attached to the transformer. It is a good idea to extend these wires by soldering about 2 feet of hookup wire to each one. You can then leave the speaker attached to the radio chassis, and even replace it in its cabinet; this will improve its tone quality.

You may not have an old radio that can be taken apart, in which case you will not have a speaker with an output transformer mounted on it. The speaker and transformer will then be bought separately. It will be necessary to identify the primary and secondary leads of the transformer. These are usually color-coded by the manufacturer; primary leads are red and blue, while secondary leads are black and green. It is not necessary to mount the output transformer directly on the speaker. This is done commercially in order to save space. Mount your output transformer in any convenient location on the baseboard and run leads to the speaker, which can be kept some distance away.

In all of our transistor circuits a doorbell transformer may be used as an output transformer, with excellent results. The heavy wire transformer leads are always connected to the primary winding. Two terminals on the other side of the transformer are the secondary-coil connections.

Transformers designed for use with model trains make fine output transformers for transistor circuits. The end that is usually plugged into the house current receptacle is the primary. The secondary winding is the one that is attached to the train tracks. Some train transformers have a control which can be used to change their voltage output. Try the control in different positions to see whether there is any difference in the tone produced in the loudspeaker.

## Chapter 6 ELECTRONICS EXPERIMENTS

### Circuit No. 1: Simple Crystal Detector Receiver

parts needed

type 1N34 crystal diode detector, or equivalent  
headphones  
antenna  
ground

The simplest radio receiver you can make consists of a crystal detector and a pair of headphones. These should be connected to an antenna and a ground, as shown in the circuit diagram. The accompanying pictorial illustration shows how the actual connections are made.

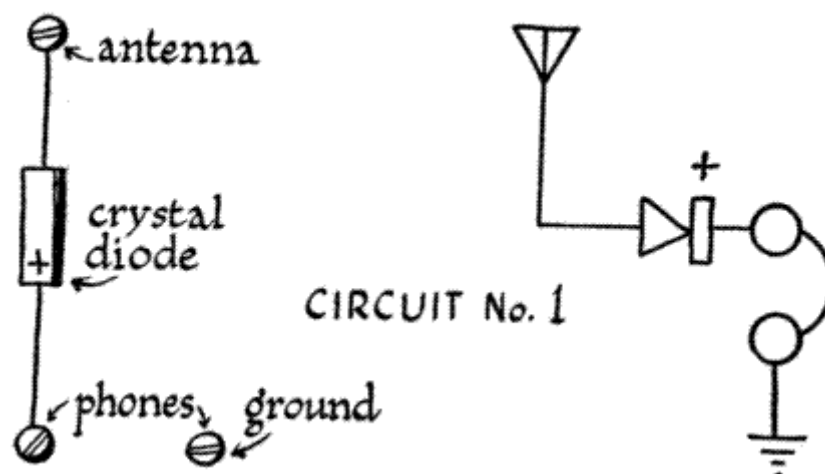



If you hook up the parts properly you will get radio reception. Several stations may come in at the same time, but this must be expected, since the circuit contains no provision for separating signals. This simply demonstrates that you can build a working radio with very few parts.

Circuit No. 2  
Crystal-Detector Receiver with Hand-Wound Coil

parts needed:

crystal diode detector  
headphones  
hand-wound coil (see p. 57)  
antenna  
ground

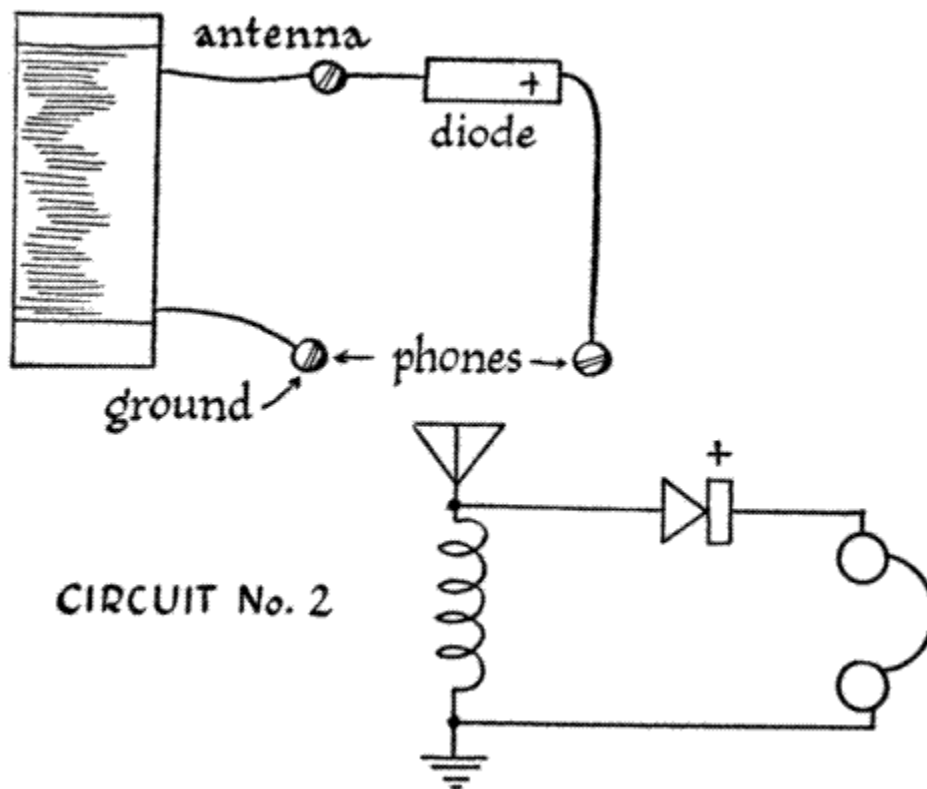

Let's add a coil to our elementary receiver. There will be an immediate increase in volume. Current developed in the coil is also induced in the windings of the headphones, since they are both connected in parallel. However, we still cannot separate incoming signals; the receiver lacks selectivity.

Circuit No. 3:  
Emergency" Crystal-Detector Receiver

parts needed

safety pin  
hand-wound coil

pencil graphite  
 antenna  
 coin  
 ground  
 headphones

This experimental circuit shows how a radio receiver can be quickly put together in an emergency. The only commercially made part you need is a pair of headphones.

The detector, the most important part of the receiver, can easily be improvised. A "cat's whisker" is made from a safety pin, and any coin can be used instead of galena. Use pliers to bend the pin so that it barely makes contact with the coin. The illustration shows how the detector is mounted on a baseboard. If you are patient and make the right contact in exactly the right spot, it will work.

You can improve the cat's whisker very easily. Sharpen a pencil, then carefully cut away enough wood to expose 1 inch of lead. Break it off and fasten it to the end of the safety pin with about a dozen turns of bare wire.

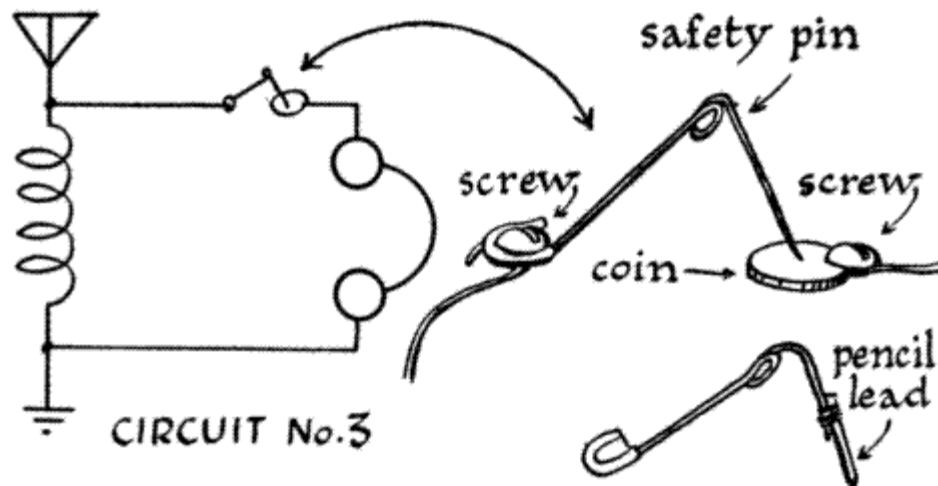

Remove the coin and try several steel objects such as razor and knife blades. You will find that most other metals also make good detectors. Programs can be heard through scraps of aluminum, galvanized iron, brass, copper, and silver. Do not brighten or polish them in any way. The best results will be obtained when the pencil tip rests against a tarnished surface. The exact pressure exerted by the pencil-tip cat's whisker must be determined by experiment. Bend the safety pin until it just barely makes contact with the metal detector.

#### Circuit No. 4 Crystal Detector Receiver with Tuned Circuit

parts needed:

crystal diode  
 headphones  
 hand-wound coil  
 variable capacitor (about 365uuF)  
 antenna

## sliding arm for coil ground

We have improved the selectivity of circuit No. 3 by adding a variable capacitor. The combination of the capacitor and coil makes a tuned circuit. Varying the capacitance changes the frequency to which the tuned circuit is particularly sensitive. If we vary the coil's characteristics, or inductance, we can make the receiver even more selective. This can be accomplished by making a sliding arm which taps the coil as the arm is moved across the top surface of the coil. The arm is made from a piece of wire coat hanger or other stiff wire, shaped as shown in the illustration. Bend the wire with a pair of pliers, then scrape all the paint from the ends of the shaped piece, exposing bright metal underneath. Mount one end of the arm on the baseboard. The other end should be adjusted so that it scrapes the top of the coil. Wipe it across the coil a few times, leaving a mark on the insulated wire. Scrape all the insulation from the coil windings at those places that have been touched by the arm. Use a knife blade, sandpaper, or emery cloth. Move the arm across the coil: it must make firm contact with the bare wire. If it seems loose, remove it from the coil and reshape it with your pliers.

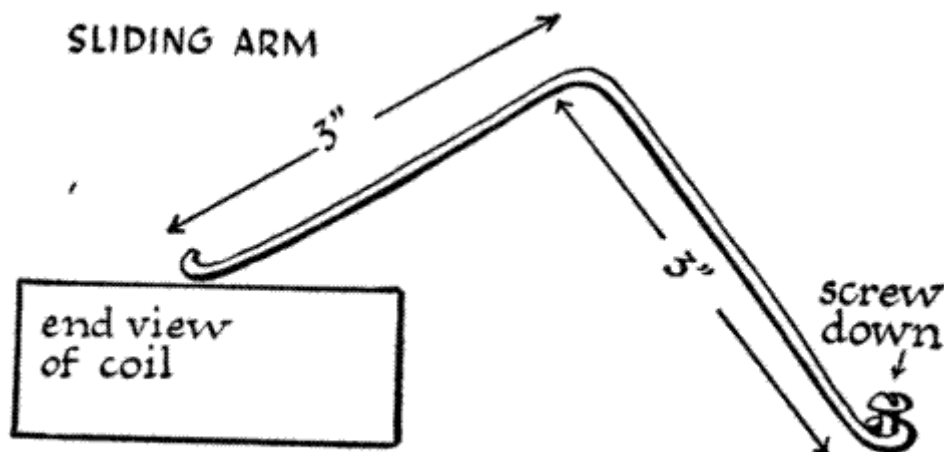

This simple tuned circuit will enable you to separate stations to some degree, but you must not expect perfect selectivity. Nearby stations may create strong interference.

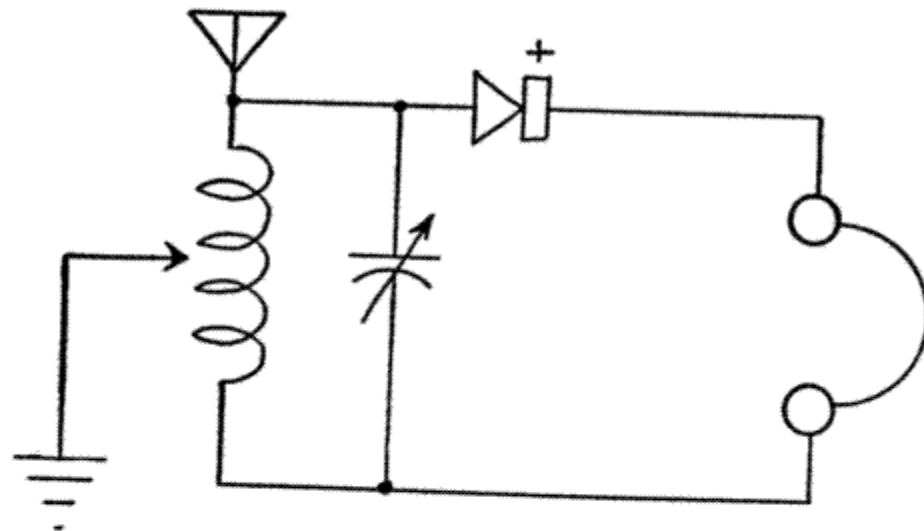

CIRCUIT No. 4

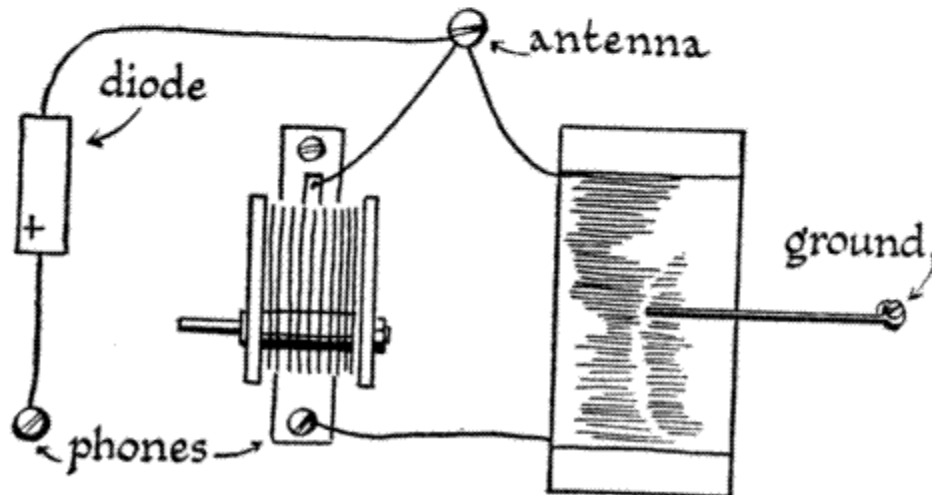
Circuits Nos. 5, 6, 7, 8, 9:  
Simple Transistor Hookups

parts needed

1 transistor, any type  
antenna  
headphones  
ground

Transistors are somewhat like crystal diodes; they are also made of germanium, a semiconductor (see page 47). Instead of having two leads like a diode, a transistor has three leads. These are identified as the collector (c), base (b), and emitter (e). Since the transistor is a semiconductor, it will also function as a detector. Simple hookups can be made using a transistor and a pair of headphones;

they must be connected to an antenna and ground. Any transistor may be used; both P-N-P and N-P-N types will work. These circuits will deliver varying degrees of volume; try them all.

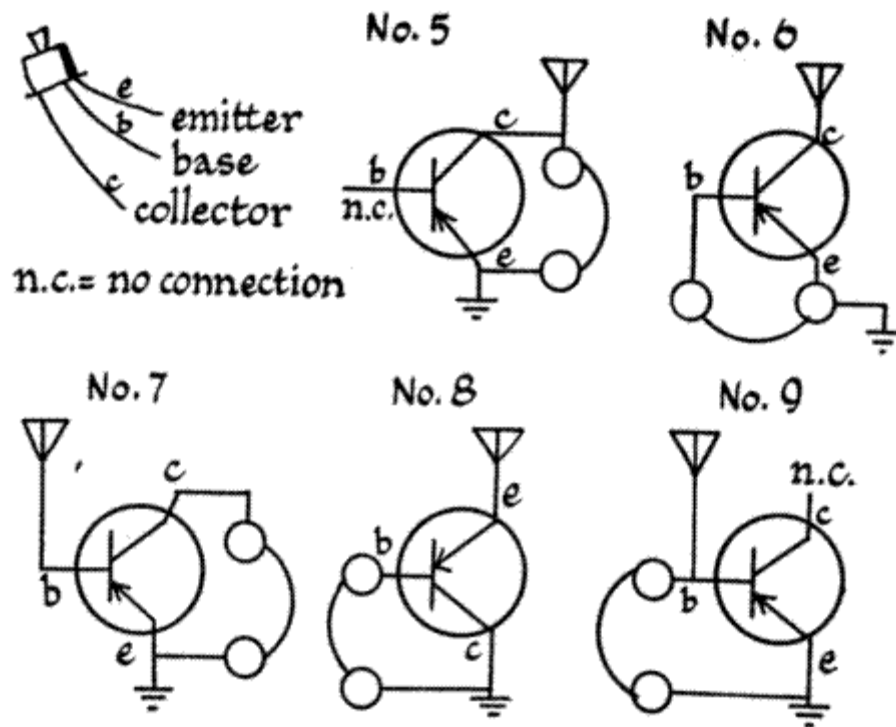

Circuit No. 10  
Single Transistor Receiver with Hand Wound Coil

parts needed

type 2N107 P-N-P transistor, or equivalent  
headphones  
hand-wound coil  
antenna  
ground

This is the next logical development in the construction of a transistor receiver. Current picked up by the antenna is fed into the coil, which forms a simple, nonvariable tuned circuit. The transistor acts as a detector and also amplifies the signal slightly. There should be an increase in volume over circuits Nos. 5 to 9.

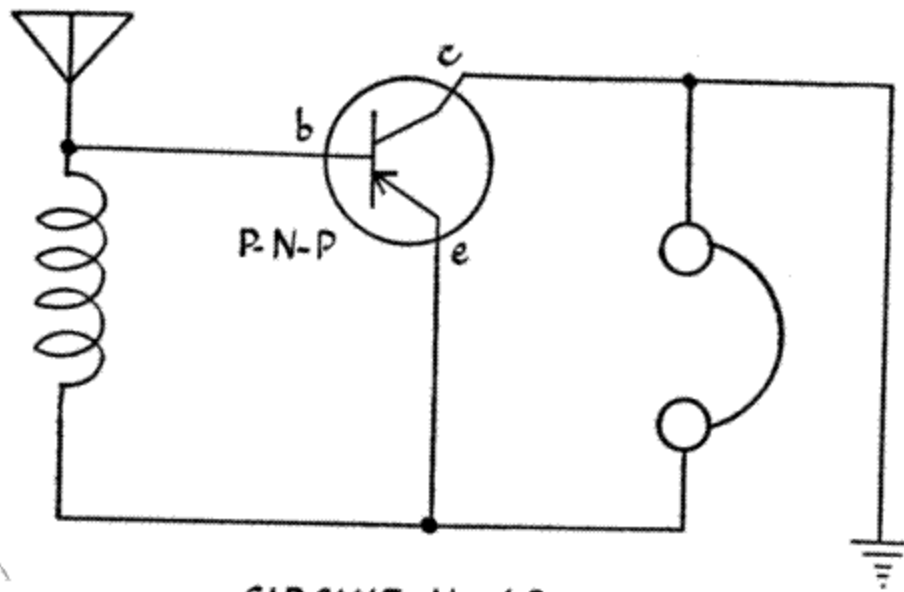

CIRCUIT No. 10

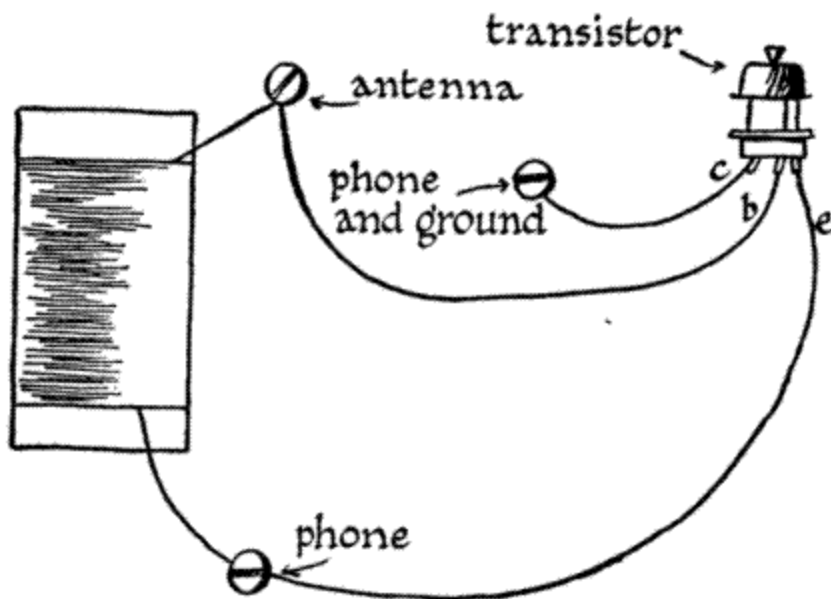

None of the circuits described up to this point requires power supplies. No batteries or other source of current has been needed. We have been able to pick up electromagnetic waves with the antenna and convert them into sound. Battery power supplies are used in the circuits that follow.

Circuit No. 11  
Crystal-Detector Receiver with Transistor Amplifier

parts needed

type 2N107 P-N-P transistor, or equivalent  
1N34 Crystal diode  
variable capacitor  
.02uF fixed capacitor  
220,000-ohm resistor  
SPST (single-pole single throw toggle switch)  
3-volt power supply  
headphones  
antenna  
ground

In this circuit a single-transistor amplifier has been added to the crystal-detector receiver shown in circuit No. 4. A resistor is also added to limit the current applied to the base of the transistor. An N-P-N transistor such as 2N170 may be substituted for the P-N-P type, in which case the battery leads must be reversed. The transistor acts as a current amplifier and will make reception considerably louder. There should be enough volume to drive a loudspeaker. When connecting the loudspeaker, remember that the secondary of the output transformer is connected to the voice coil, and the primary leads go to the phone terminals. Not all output transformers will work equally well. They have different characteristics, depending on the type of tube for which they were originally designed. Special transformers have been designed for use with transistors, but we are using components that are available everywhere. If you have more than one transformer, use the one that provides the loudest signal.

It is important to observe the correct polarity (connections of + and - leads) when hooking up the power supply, or the transistor will be damaged. A 3-volt supply (two flashlight cells in series) will work in this circuit.

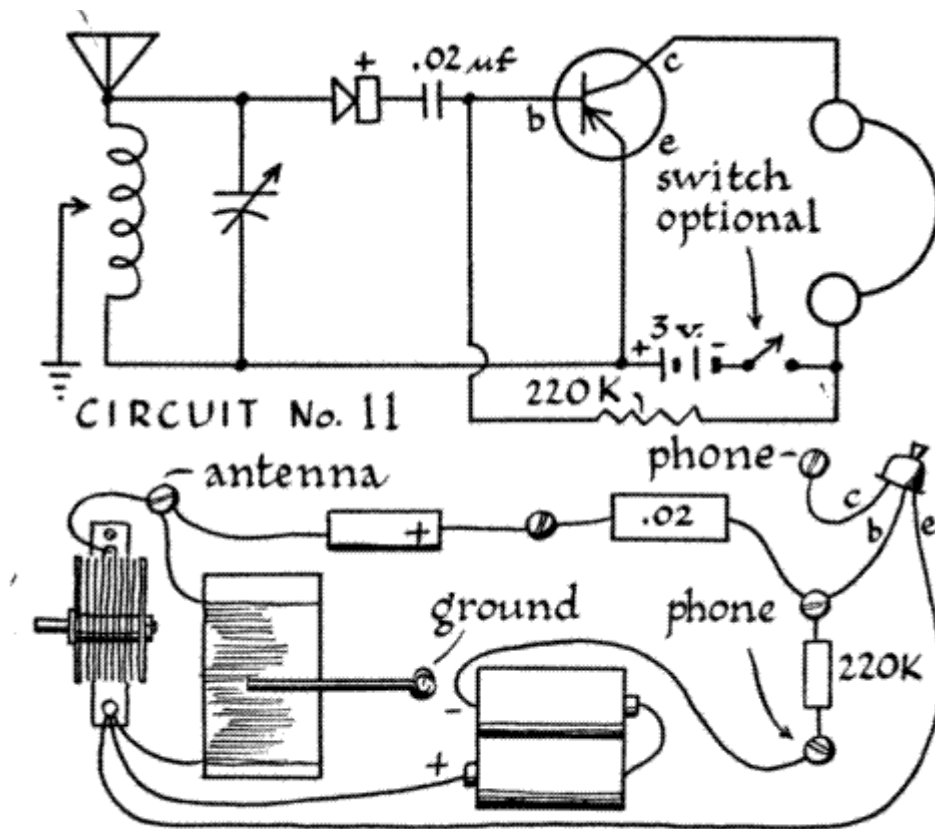

The diagram shows a switch, which is convenient but not essential. Just disconnect one of the power supply leads when the set is not in use.

Do not expect the volume of this receiver to be comparable to that of a commercially built radio. Strong local stations will be heard very well, while distant or weak stations will come through with decreased volume. This is an experimental circuit, the purpose of which is to show that a single-transistor amplifier can develop enough power to drive a loudspeaker.

#### Circuit No. 12: Two-Transistor Receiver

parts needed

- hand-wound coil
- 4000-ohm resistor
- SPST switch
- variable capacitor
- 2 type 2N107 P-N-P transistors, or their equivalents
- headphones
- antenna
- 3-volt battery power supply
- ground

In this circuit the first transistor is used as a detector amplifier. It is coupled directly to the second transistor which acts as an audio amplifier. In Other words, the first transistor not only detects the



incoming signal but also amplifies it. The amplified signal is fed from the collector of the first into the base of the second transistor, where it is amplified further. From here it goes to the phones, where the electrical impulses are converted to sound.

Reception will be much louder than that provided by the preceding circuit. Loudspeaker connections are indicated on the circuit diagram. Use a single-pole single-throw (SPST) switch.

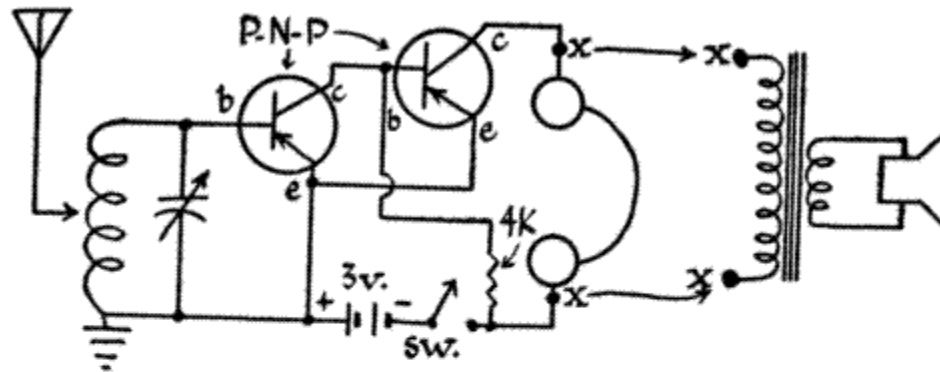

CIRCUIT No. 12

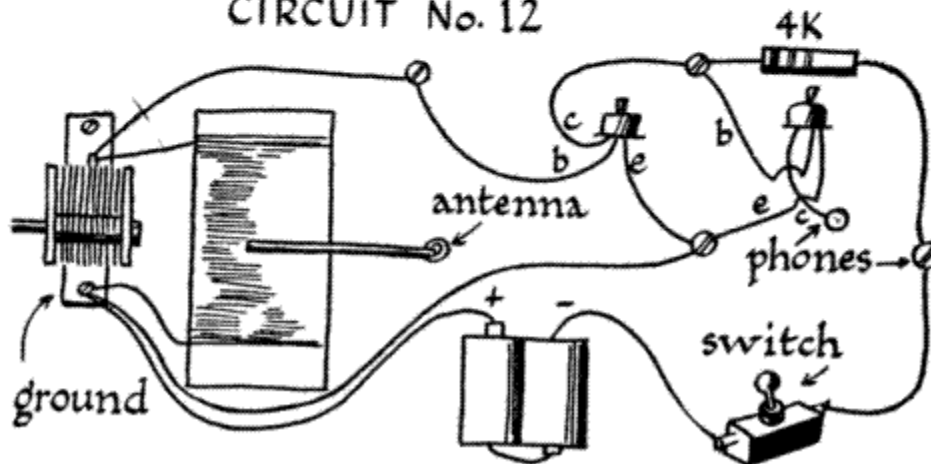

Circuits Nos. 1 to 12 have been shown in both pictorial and diagrammatic form so that beginners can become familiar with construction practices. Experienced radio men never use pictorial illustrations. Anyone who wants to work with electronics must learn to interpret diagrams. For this reason, only circuit diagrams will now be given.

Circuit No, 13:  
Two-Transistor Receiver

parts needed:

hand-wound coil  
variable capacitor  
1N34 crystal diode  
type 2N170 N-P-N transistor, or its equivalent  
type 2N107 P-N-P transistor, or its equivalent  
4700-ohm resistor  
100uuf fixed capacitor  
25uf fixed capacitor

headphones  
 6-volt power supply  
 SPST switch  
 antenna  
 ground

The signal is detected by the crystal diode, amplified by the N-P-N transistor and coupled directly to the P-N-P transistor, which acts as a second amplifier. Direct coupling was used in circuit No. 12, but coupling from one P-N-P transistor to another is not too effective. A much greater gain, or increase, in signal strength can be obtained by feeding the signal from an N-P-N transistor into a P-N-P type. Volume should be increased in this circuit, so that a loudspeaker can be used to good advantage. If you do not already know them, refer to other circuits for loudspeaker connections.

Certain precautions must be observed when using both P-N-P and N-P-N type transistors in the same circuit. They are not interchangeable and can easily be ruined if they are accidentally switched. Also, make it a practice to see that the switch is in the off position before inserting transistors into their sockets.

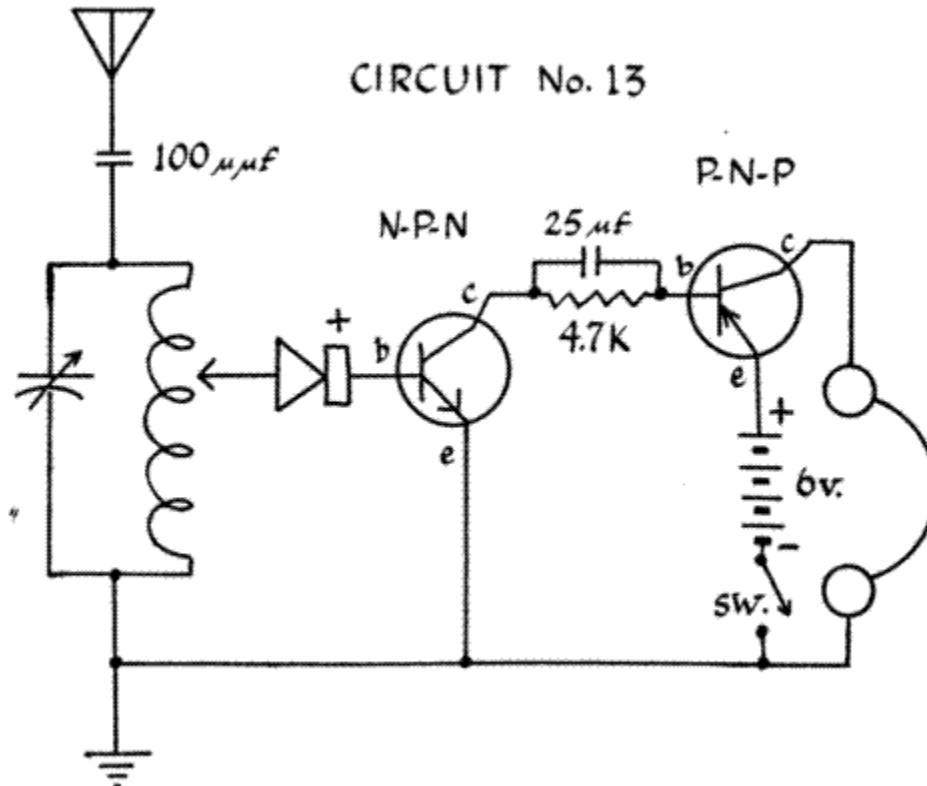

Circuit No. 14  
 Two-Transistor Receiver

Parts Needed:

hand-wound coil  
 variable capacitor

1N34 crystal diode  
 5600-ohm resistor  
 100uuf fixed capacitor  
 headphones  
 2N107 P-N-P transistor, or its equivalent  
 6-volt power supply  
 2N170 N-P-N transistor, or its equivalent  
 SPST switch  
 antenna  
 ground

This circuit is essentially the same as the preceding one. The only difference is that in this case a P-N-P transistor is used in the first (detector-amplifier) stage, feeding the signal into an N-P-N type, which is the audio amplifier.

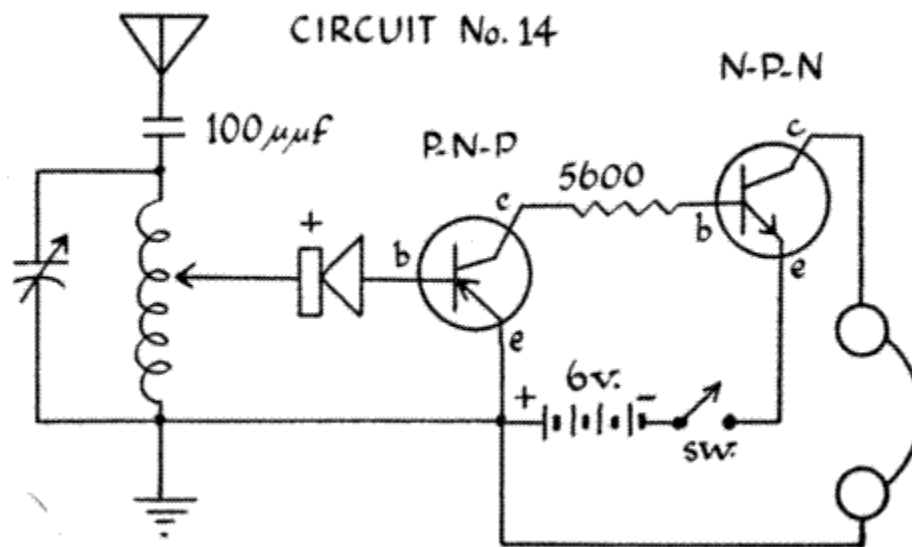

The use of the 100uuf capacitor is optional. Try the receiver with and without it; omit it if it doesn't seem to be needed.

Attach a 3- or 4-foot length of wire instead of an antenna and operate the receiver without an external ground; you may be surprised at the results. For best reception, you will, of course, need both an outside antenna and a proper ground.

#### Circuit No. 15 Single-Transistor Regenerative Detector Receiver

parts needed :

hand-wound coil with tickler winding  
 variable capacitor  
 2N107 P-N-P transistor, or its equivalent  
 5,000- to 500,000-ohm potentiometer  
 500,000-ohm resistor

.05uf fixed capacitor  
 .001uf fixed capacitor  
 100uuf fixed capacitor  
 headphones  
 SPST switch  
 3-volt power supply  
 antenna  
 ground

The first step is to modify the coil by adding a "tickler" winding. Remove the coil from the baseboard and wind 15 turns of magnet wire over the coil 1/4 inch from the end that is to be connected to ground. Fasten the winding in place with a strip of tape. Leave 12-inch leads at the ends of the tickler. Refasten the coil to the base board.

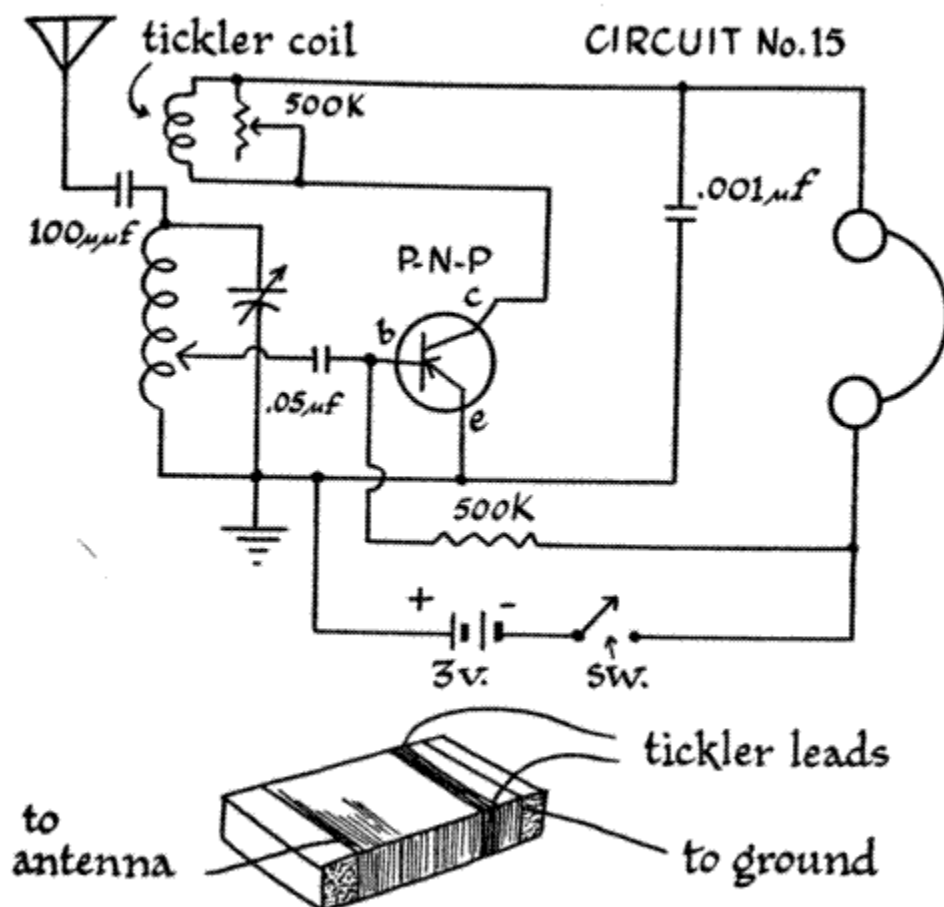

The signal is intercepted by the antenna and carried to the tuning circuit, where the desired station is selected. From here it goes to the transistor. Emerging from the collector, it goes through the tickler coil, which is magnetically coupled to the main coil. Transformer action takes place between the tickler and the large coil. Current flowing in the tickler induces current in the other coil, adding to the incoming signal strength. The strengthened signal is fed into the transistor, and again fed back through the tickler circuit. This feedback cycle is repeated over and over, and is known as regeneration.

If regeneration is unchecked, too much signal energy will be developed and it will "spill over" or oscillate. Oscillation will be heard as a whistle, buzz, hiss, or other sound distortion. The

potentiometer acts as a regeneration control.

Regenerative receivers must be tuned carefully. First tune in a station by adjusting the coil arm and the variable capacitor. Move the arm to the point where the loudest signal is heard, and leave it there. From now on all tuning is done with the capacitor. Advance the regeneration control until you hear oscillation sounds. If none are heard, it is a sign that regeneration is not taking place; the tickler leads must be reversed. Final adjustment is accomplished by turning the regeneration control so that it is just below the point of oscillation.

Regenerative receivers are very sensitive to weak signals and provide greater selectivity than many other types.

### Circuit No. 16 Two-Transistor Regenerative Detector Receiver

parts needed:

- coil with tickler winding
- variable capacitor
- 1N34 crystal diode
- 2 type 2N107 P-N-P transistors, or their equivalents
- 2 .05 $\mu$ f fixed capacitors
- 500000-ohm potentiometer
- headphones
- 3-volt power supply
- SPST switch
- antenna
- ground

This circuit is essentially the same as the preceding one, except that two transistors are used. Volume and selectivity should be increased, so that a speaker can be hooked up with good results.

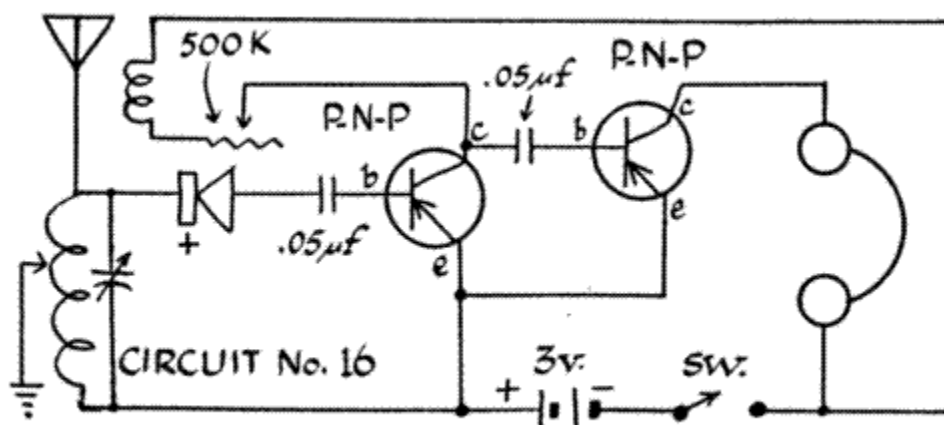

### Circuit No. 17: Solar Battery Power Supplies

A photocell is a small metal unit, one side of which is coated with selenium. When light strikes the selenium layer it is converted to electrical energy. One type of inexpensive cell may be bought which will produce .5 volt of electricity when exposed to average sunlight. The cell's output voltage is decreased under light of less intensity, so do not expect the same results when it is held under a 100-watt lamp. Other types of cells use silicon or cadmium sulfide instead of selenium. Photocells (also called sun cells or solar cells) can be used instead of batteries to supply power for any of the transistorized devices shown in this book. They are rugged and will last indefinitely as they do not wear out. However, more than one must be used, since .5 volt is not enough to energize a transistor with any degree of efficiency. At least 1.5 to 2 volts is needed. Cells can be hooked up in series to produce any desired voltage. Each unit has a red (positive) lead and a black (negative) lead. Series connections are made by soldering together the red and black leads of adjoining cells. Four photocells will furnish 2 volts. When making up a power supply unit, screw the cells to a small base, with the selenium surfaces all facing the same way. Several transistorized portable radios which are powered by solar batteries have appeared on the market. These will work anywhere provided there is a light source to which the power pack can be exposed. Since the solar cells have an indefinite life, the power supply is virtually permanent.

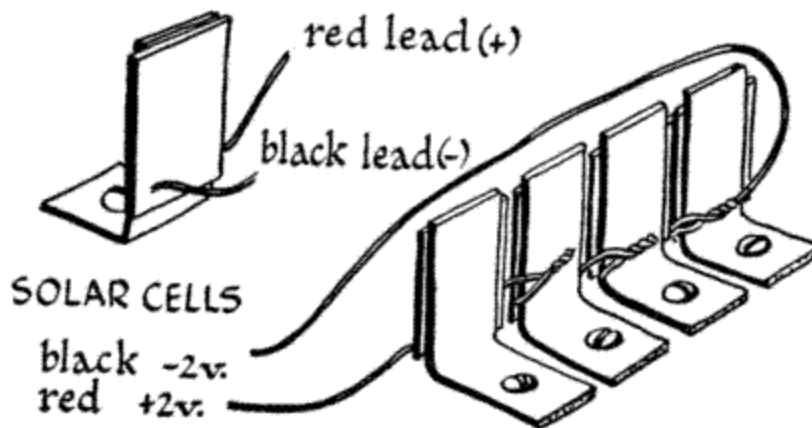

Numerous other uses have been found for solar cells, particularly in automatic devices. They are used in traffic control systems, automatic headlight dimming mechanisms, factory-line inspection systems, amusement devices, burglar alarms, door controls, garage door openers, and automatic counters.

Photocells are used in photographic exposure meters. Light is gathered by a lens and concentrated on the cell, which is connected to a sensitive meter. The meter is usually calibrated to show lens-stop openings instead of current.

#### Circuit No. 18 Sound Amplifier

parts needed:

- 2 permanent-magnet loudspeakers, about 4 inches in diameter
- type 2N170 N-P-N transistor or its equivalent
- 50,000-ohm resistor
- 2 output, doorbell or modeltrain transformers
- 6-Volt power supply

SPST switch  
type 2N107 P-N-P transistor, or its equivalent

In this circuit a small permanent-magnet speaker is used instead of a microphone. If you talk into the input speaker, your voice will be heard coming from the output speaker. The amplifier is the same as the one used in circuit No. 14, where it amplified the broadcast signal selected by the tuning circuit. In this circuit it will amplify the sound fed into the input speaker.

This is how the circuit works: When you talk into the input speaker, sound waves generated by your voice cause the cone to move. As the cone moves, it also moves the voice coil, which is centered around a powerful permanent magnet. You will remember that moving a coil through a magnetic field generates electric current.

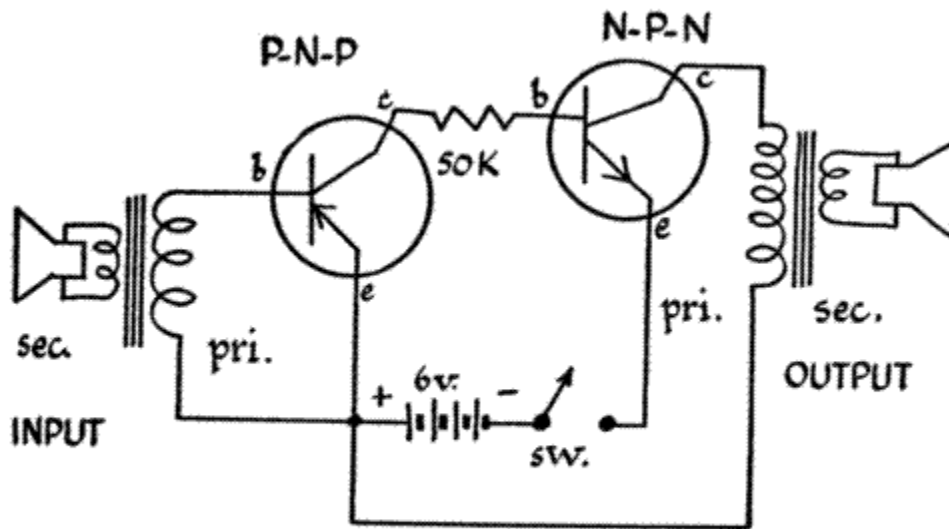

CIRCUIT No. 18

This current is transferred from the voice coil to the secondary winding of the transformer. Current is induced in the primary and fed into the base of the P-N-P transistor, where it is amplified. It then passes into the base of the N-P-N transistor where it is further amplified, and then through the primary of the output transformer. Current induced in the secondary winding causes the voice coil to move. Since the voice coil is attached to the speaker cone, sound is generated.

Notice that the output transformers are connected in the same way: the secondary windings are connected to the speaker voice coils in both cases; the primary transformer windings go to the circuit. In this circuit and the next one amplification will take place depending upon the transistors used and the efficiency of the input and output transformers.

Circuit No. 19:  
Room-to-Room Communicator

parts needed:

circuit No. 18  
DPDT(double-pole double-throw) switch

The amplifier described in circuit No. 18 can be used as a room-to-room communicator in your home. All you have to do is add a double-pole double-throw switch. The first step is to connect switch terminals A and C, and B and D, as shown in the diagram. Use insulated wire.

Disconnect the primary transformer lead that goes to the base of the P-N-P transistor, solder a piece of wire to it, and connect it to switch terminal X. Use another wire to connect switch terminal B to the base of the P-N-P transistor.

Disconnect the primary transformer winding that is connected to the collector of the N-P-N transistor, solder a piece of wire to it, and connect it to switch terminal Y. Connect switch terminal A to the collector of the N-P-N transistor with another wire.



## CIRCUIT No. 19

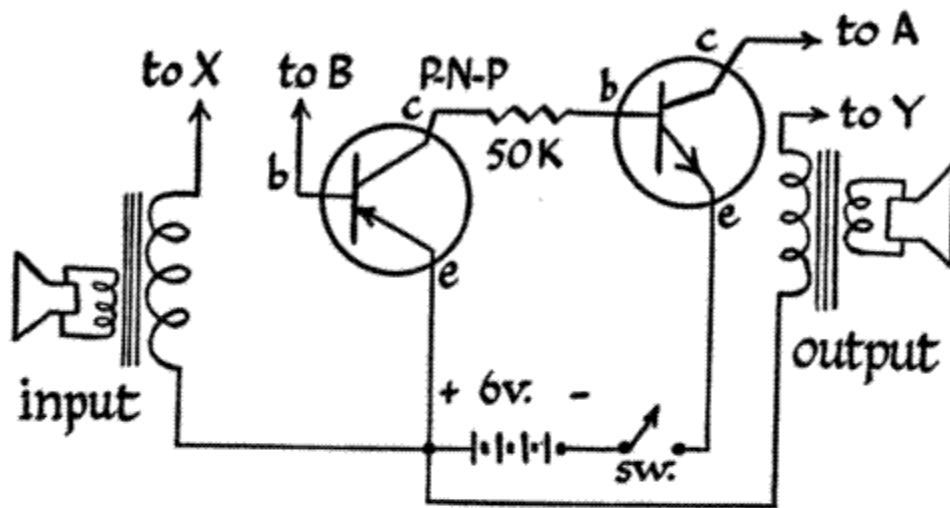

## SCHEMATIC of SWITCH CONNECTIONS

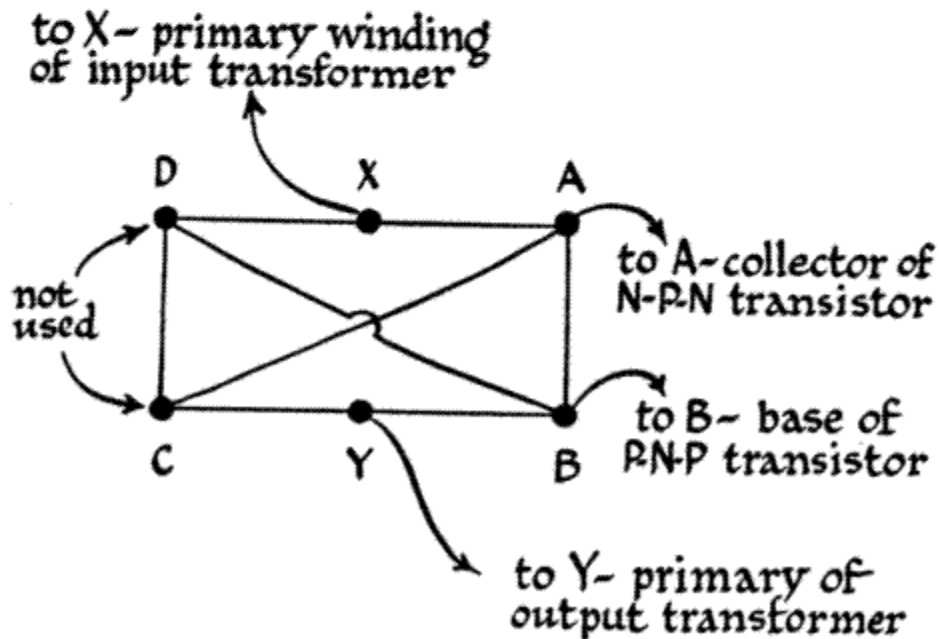

To use the amplifier as a communicator, one speaker and transformer are placed in a remote position. This may be another room or another floor of your house. Two long wires will have to extend from the speaker position to the amplifier. One wire runs between the transformer primary and a terminal on the DPDT switch. The other wire connects the other end of the transformer primary to the positive power supply terminal.

Either speaker may be placed at a distance; it makes no difference. Any wire may be used. However, the switch should be mounted on the baseboard so that it is easily accessible.

When the switch is in one position, one of the speakers is the microphone input and the other is the sound reproducer. When the switch position is reversed, the functions of the speakers will be reversed. The one that was formerly the input speaker will now be in the output circuit. You cannot talk and receive at the same time.

Mark the switch positions so that one is labeled "talk" and the other "receive".

Cigar boxes make good cabinets for both the basic unit and the remote speaker.

Circuit No. 20:  
Wireless Broadcast Oscillator

parts needed:

home-wound coil, or ferrite loopstick  
variable capacitor  
P-N-P transistor  
500,000-ohm potentiometer  
RF choke  
25 to 50uuf fixed capacitor  
2. 005uf fixed capacitors  
PM speaker or headphone(s)  
SPST switch  
6-volt power supply  
6-foot wire antenna

This oscillator is a miniature transmitter. It sends out a signal, such as your voice, that can be picked up by any nearby broadcast receiver. Audio (AF) signals are those which have a frequency of from 15 to about 20,000 cycles. Above 20,000 cycles they are known as radio frequencies, or RF. The oscillator generates an RF signal which falls somewhere between 550 and 1650 kilocycles, the range of the average radio receiver. This is the carrier wave, and may be heard in the receiver as a loud hiss.

A permanent-magnet speaker is used as a microphone. It is connected to the circuit through whatever type of transformer you happen to have at hand. Single or double headphones can also be used as a microphone. Their leads are connected directly to the input of the oscillator. No transformer is needed.

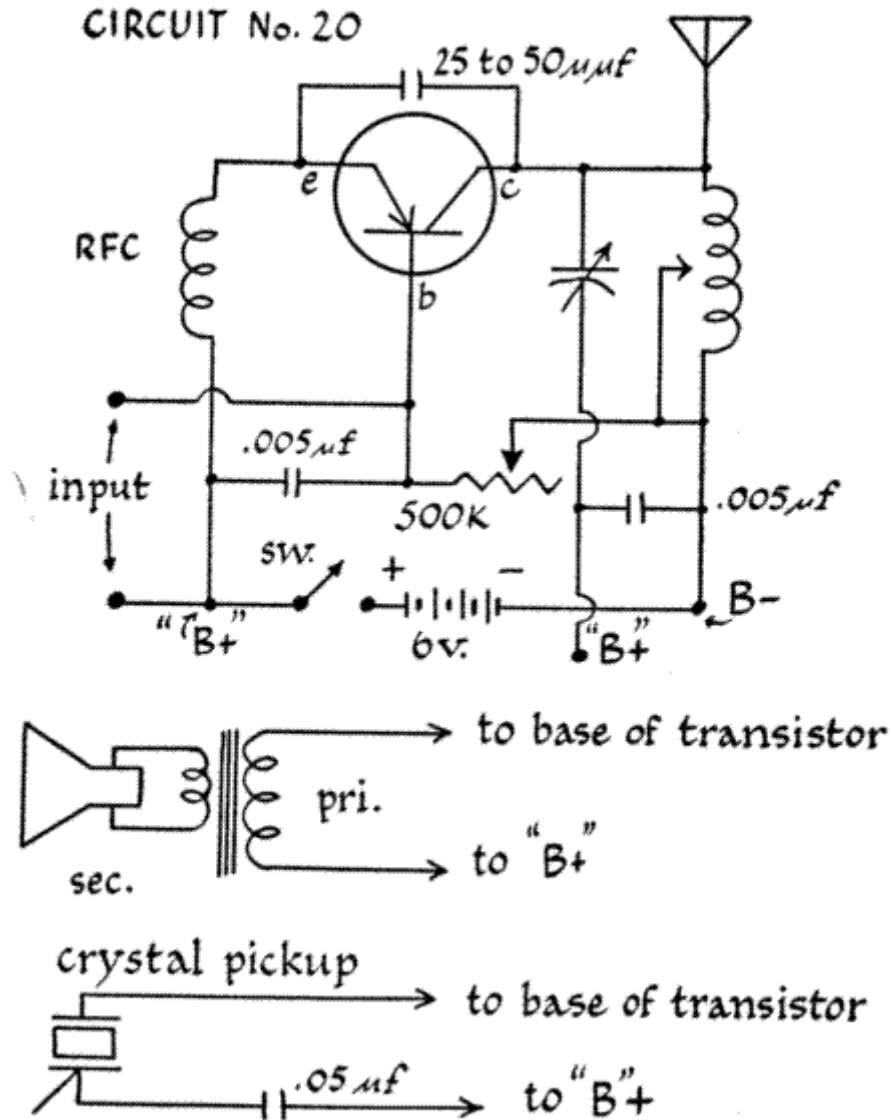

When you speak into the microphone, an audio signal is generated. This is mixed with the carrier wave and broadcast through the antenna. The transmitted electro magnetic wave now has two components: the RF carrier and the low-frequency audio current.

If you examine the circuit, you will see the familiar combination of a coil and a tuning capacitor, which make up a tuned circuit. This is adjusted to vary the frequency of the transmitted signal so that it may be picked up at different points on the receiver dial

You will also see that a 6-foot piece of wire is used as a transmitting antenna. Do not connect this oscillator to an outside or other long-wire antenna, or your broad casts may be picked up by your neighbors. Even though we are using a flea-powered transmitter, its range can be extended when it is coupled to an efficient antenna. This would be a violation of Federal Communications Commission regulations.

Almost any transistor can be used in this circuit. However, some may oscillate better than others. If you have more than one, try them all. Remember to reverse the battery leads when using N-P-N types.

Although you can use your home-wound coil, results will be far better if you use a ferrite loopstick, already described.

Construct the circuit and hook up the transmitting antenna. Place the oscillator within a few feet of

a radio receiver, and turn them both on. Tune the receiver carefully, listening for the hiss that indicates you are receiving the transmitted signal. Now turn off the oscillator; if the hiss can no longer be heard in the receiver, you may be certain you have picked up the proper signal.

If you cannot pick up the oscillator's signal, try it another way. Set the receiver at an unused portion of the band where there is no station, somewhere near the center of the dial. With the oscillator on, adjust the tuning capacitor until the signal is brought in. If you are using a home-wound coil and you cannot tune in the signal, it may be necessary for you to substitute a ferrite loopstick. This can be tuned by screwing the ferrite slug in and out of position. The sharp tuning circuit formed by the loopstick and variable capacitor should bring in the signal at almost any point on the receiver dial.

Now talk into the microphone; your voice should be heard coming out of the receiver. Adjust the potentiometer to control the volume and clear up any distortion that may be present.

It is most important that you select an unused portion of the receiver band. If there is any incoming signal at that point the oscillator's output will combine with it to produce a third signal, or heterodyne. This will distort your voice; the only way to get rid of a heterodyne is to shift the frequencies of both the oscillator and the receiver.

The circuit contains a radio-frequency choke, marked RFC in the circuit diagram. This is a small coil with fine windings. Its purpose is to restrict the flow of alternating RF currents, while permitting direct current to pass through.

The oscillator can also be used to broadcast phonograph music. You can play records without using an amplifier and have the sound come out of the radio. However, the arm of your record player must have either a crystal or ceramic pickup cartridge. Magnetic pickup cartridges do not generate enough current. A shielded wire usually runs from the pickup arm to the amplifier of the record player. This must be disconnected at the amplifier. The inner wire is then connected to the base of the transistor. Solder a wire to the flexible metal wire shield, and connect it to a .05/ capacitor. Connect the other end of the capacitor to the "B" plus supply. Turn on the oscillator, and place the pickup arm on a record; the music will be broadcast.

## **Chapter 7**

### **HOW A VACUUM TUBE WORKS**

Vacuum tubes perform many functions in electronic circuits. They are used as detectors, amplifiers, and generators of high-frequency currents. We know that the flow of current in a conductor is caused by the movement of free electrons. At ordinary temperatures the electrons remain within the conductor. However, as the temperature of the conductor is raised, the velocity, or speed, at which the electrons travel is also increased. If the conductor is heated to incandescence, electrons can actually fly off into space. This is called thermionic emission.

Within some types of vacuum tubes electrons are given off by a thin wire called the filament; these are directly heated tubes. If a filament is heated in air, it will soon disintegrate. It has been found that when emission takes place within a vacuum, the filament will not burn up because no air is present. Consequently, the air is removed from all vacuum tubes.

In other types of tubes the filament heats another metallic surface known as the cathode, which becomes the electron-emitting element; these are indirectly heated tubes. Any surface that gives off electrons within a tube is called the cathode.

The cathode is connected to a source of current, either directly or indirectly. As current flows through it, it becomes heated so that it glows. Some of the free electrons gain enough energy to fly off into surrounding space. However, they tend to cluster around the cathode in a cloud. These electrons in the vicinity of the cathode form a negative charge; this is called a space charge.

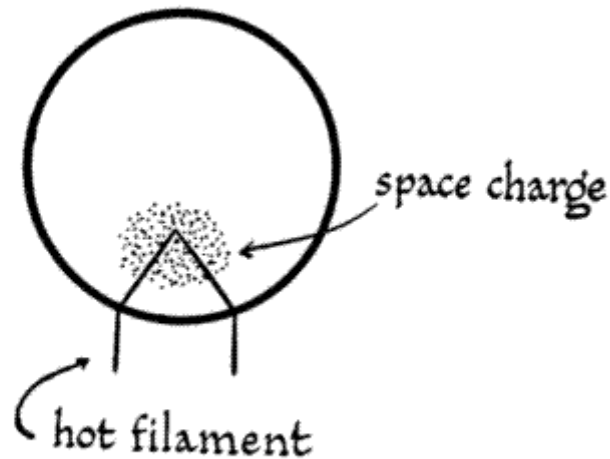

Particles with similar charges repel each other, and oppositely charged particles attract each other. As new electrons are given off by the cathode, the negative space charge tends to repel the new arrivals, pushing them back on to the surface of the cathode.

The simplest form of vacuum tube contains two elements. It is known as a diode. In addition to the cathode it has a plate, which is actually a small metal plate. When a positive charge is placed on the plate, it attracts negatively charged electrons within the tube. Electrons move from the cathode to the plate, causing current to flow.

The moment the positive voltage is removed from the plate, the flow of current stops. If a negative charge is placed on the plate, it will repel electrons and no current will flow.

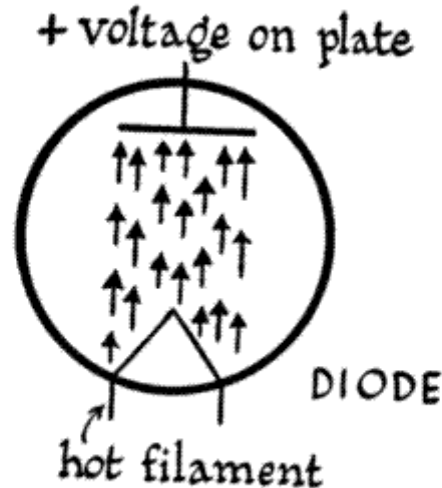

The flow of current within the tube can be increased by raising the plate voltage. The greater the positive charge on the plate, the more electrons it will attract. However, the flow of electrons can be controlled more easily by inserting a third element between the cathode and the plate. This is the grid, an open winding of fine wire. A tube that contains a cathode, grid, and plate is called a triode. The grid acts as an electronic valve that controls the flow of current between the cathode and the plate. In order to function, it must be supplied with either positive or negative voltage. When the grid has a high negative charge it repels all the electrons emitted by the cathode and does not permit any to get through to the plate; there is no flow of current. As the negative voltage or bias is decreased, more electrons reach the plate and there is an increased flow of current. When the grid is at zero potential (no voltage applied) it has no effect whatsoever; the flow of current between cathode and plate is

uninterrupted. When the grid is positive it helps the plate to attract electrons from the cathode; the current flow is increased. Up to a certain point an increase in positive grid voltage will result in an increase in plate current.

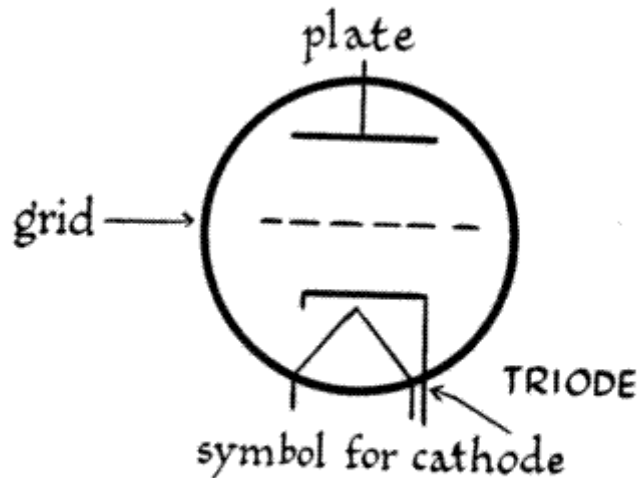

Thus, the polarity (positive or negative condition) of the grid voltage controls the flow of current within the tube. For this reason it is often called the control grid.

A small variation in grid bias causes a much larger variation in plate current. If we apply a weak signal to the grid, it will be strengthened, appearing as a strong signal at the plate. This makes it possible to use a vacuum tube as an amplifier in a receiver. The alternating-current RF signal intercepted by the antenna is fed into the grid. It then appears as a greatly amplified signal at the plate.

A tetrode is a tube that contains four elements. It has a cathode, a control grid, a plate, and an additional grid called the screen grid, which is located between the control grid and the plate. The screen grid acts as a shield around the control grid. Since it is supplied with positive voltage, it helps draw electrons to the plate.

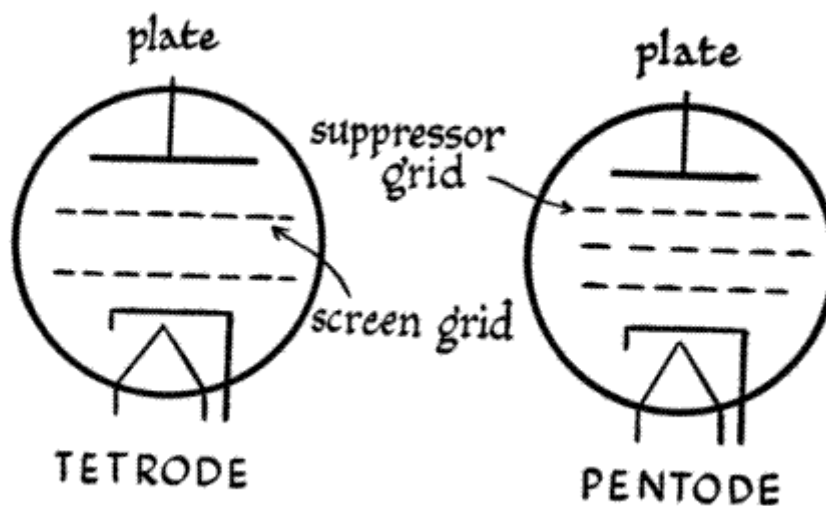

Electrons emitted by the cathode travel at great speed. Some of them strike the plate with enough force to dislodge other electrons, which are thrown into space. Since the screen is positively charged, these secondary electrons are attracted to it. This causes secondary emission, a condition in which a

reverse flow of current takes place from plate to screen.

The undesirable effects of secondary emission are overcome by inserting a third grid, the suppressor grid, between the screen and the plate. This suppressor, which is connected to the cathode, acts as a shield and prevents the screen from attracting secondary electrons. These electrons are now forced back to the plate. Tubes that contain five elements (cathode, control grid, screen grid, suppressor grid, and plate) are called pentodes.

A wire is brought from each tube element to a terminal pin in the base. Tubes are made to fit special sockets. Each type of socket accommodates tubes with a different number of pins. The socket is wired into the circuit, so that tubes can be inserted or removed whenever necessary.

Tube diagrams must be interpreted carefully. The grid nearest the cathode is always the control grid. If a tetrode is shown, the screen is always indicated as a second grid, placed between the control grid and the plate. In a pentode the suppressor is shown as a third grid placed between the screen and the plate.

Circuit diagrams sometimes show numbers next to the symbol for each element. These numbers refer to the pins at the bottom of each tube. To interpret tube-pin numbers, look at the bottom of the tube. Miniature glass tubes, the type used in this book, do not have bases. Instead, the terminal pins are brought directly out of the glass tube envelope. Two pins are spaced wider apart than the others; the one at the left is always pin No. 1. The other pins are numbered clockwise, from left to right.

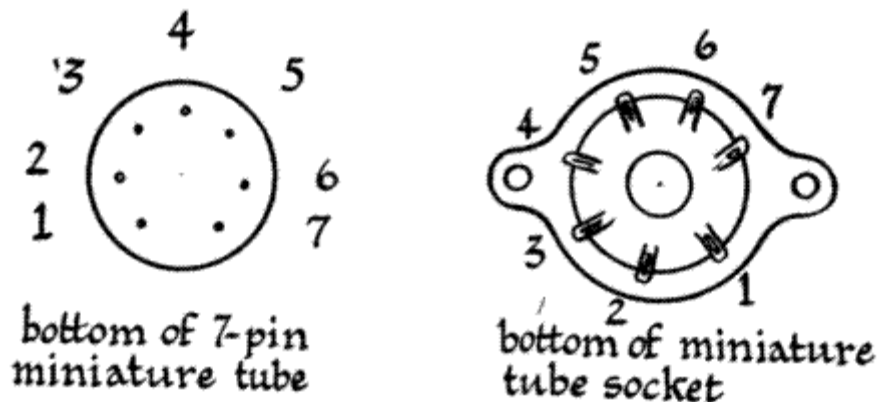

Tube socket terminals are numbered in the same way. Be sure to look at the bottom of the socket.

#### Circuit No. 21:

#### Vacuum-Tube Grid-Leak Detector Receiver

parts needed:

- type 3V4 tube
- .05uf fixed capacitor
- 7-pin miniature tube socket
- SPST switch
- ferrite loopstick
- variable capacitor
- headphones
- 1- to 5-megohm resistor
- 100uuf fixed capacitor
- .001uf fixed capacitor
- 1 1/2 volt "A" battery (filament supply)

22 1/2-volt to 67 1/2-volt "B" battery  
antenna  
ground

Although transistors in many respects are superior to vacuum tubes, this circuit is included as an example of a simple, easy-to-build vacuum-tube receiver and to show how a tube works. You will notice that this circuit does not make use of a crystal-diode detector. Instead, detection takes place in the grid of the tube. The resistor connected to the grid is known as a grid leak. Incoming signal voltage must pass through the grid leak; as it does, some of it is consumed as it forces its way through the high resistance it encounters. This is known as a voltage drop. As the signal varies, so will the voltage drop across the resistor. This causes the grid voltage to vary. In turn, the plate current varies in step with the changing grid voltage. Since the plate current flows through the headphones where it is converted to sound, it can be seen that the voltage drop across the grid leak is responsible for the receiver's output.

Grid-leak detectors are very sensitive and are good at bringing in weak signals. They ordinarily use resistors of from 1 to 5 megohms. Their chief disadvantage is that they are easily overloaded, or distorted by strong signals. This condition can be improved to some extent by reducing the size of the grid-leak resistor. While this will cut down overloading, it will also reduce the sensitivity of the circuit.

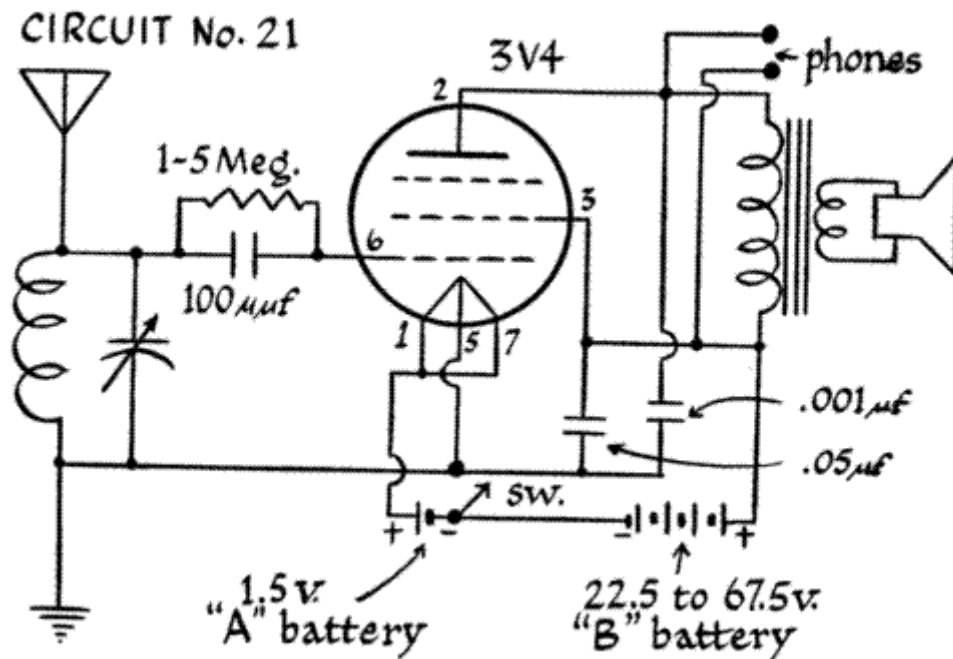

This receiver should provide fine reception with head phones, but it may not operate a loudspeaker satisfactorily.

A type 3V4 pentode is used as a detector-amplifier. A triode can be used just as well, but the pentode provides an increased gain in signal strength. If you do not have a 3V4 tube, try a 1AE4, 1AF4, 1AJ4, 1L4, 1U4, 1T4, or a 3E5. The 3E5 may be substituted for the 3V4 without any circuit changes. When using the other tubes, a change must be made in the filament wiring. Pin No. 1 will be connected to "A" +; pin No. 7 will go to ground; pin No. 5 is not used.

The tube filament is heated by a 1 1/2-volt power supply. You can use either 1 flashlight cell or a large 1 1/2-volt battery. The filament battery is always known as the "A" battery. Plate voltage is



supplied to the tube by a "B" battery, of the type used in portable radios. It may be rated at anywhere from 22 1/2 to 67 1/2 volts.

The negative terminals of the "A" and "B" batteries are connected to one of the switch terminals. The other side of the switch is grounded. When the switch is closed, current will flow in both the A and B (filament and plate) circuits.

Circuit No. 22:  
One-Tube Regenerative Receiver

parts needed:

type 3V4 tube  
7-pin miniature socket  
ferrite loopstick with tickler winding  
variable capacitor  
loudspeaker and output transformer, or headphones  
1- to 5-megohm resistor  
100,000-ohm resistor  
.05uf fixed capacitor  
.001uf fixed capacitor  
100 uuf fixed capacitor  
RF choke  
50,000-ohm potentiometer  
SPST switch  
IX-volt "A" battery  
(filament supply)  
22 1/2-volt to 67 1/2-volt "B" supply  
antenna  
ground

Make a tickler by winding 15 turns of magnet wire directly over the loopstick coil. Fasten the winding in place with a strip of tape. Leave about 12 inches of wire extending from each end of the tickler.

The construction of this circuit is almost identical to that of the preceding one. The only difference is that a tickler coil and a few parts have been added so that the receiver will operate as a regenerative detector.

As in circuits Nos. 15 and 16, regeneration takes place when some of the output voltage is fed back into the input circuit so that it reinforces the input voltage.

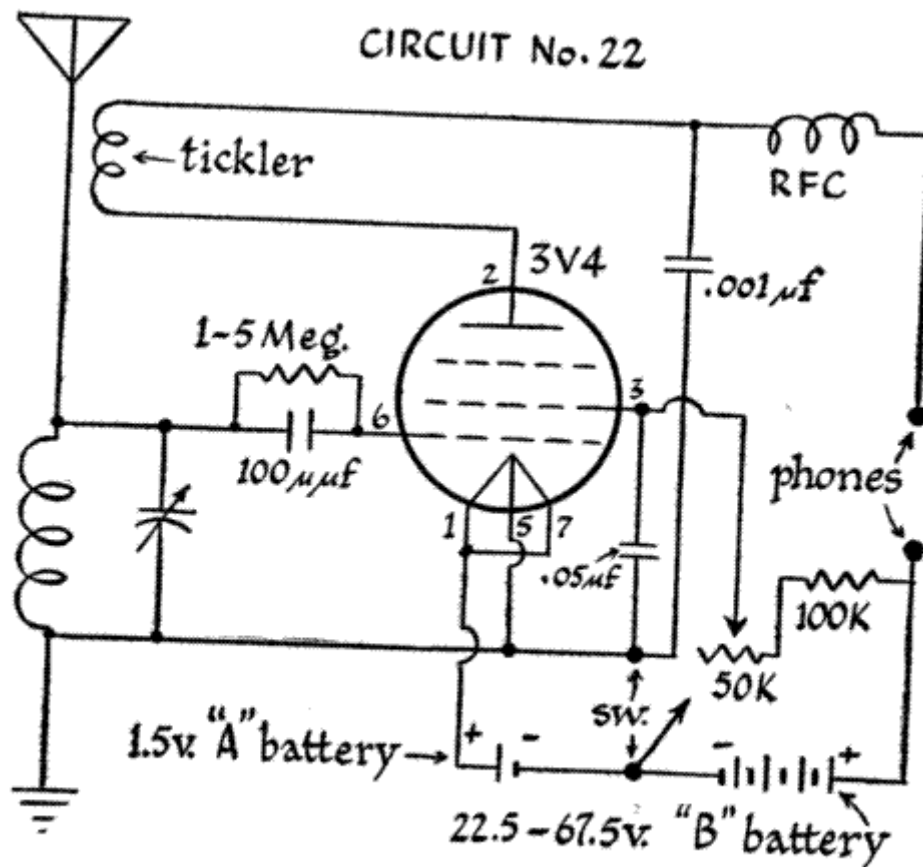

The RF choke in the tickler-plate circuit prevents the high-frequency RF alternating current from flowing through the headphones. This current is by-passed to ground through the .001uf capacitor, which provides an easy path.

A 100,000-ohm resistor is shown connected to one end of the potentiometer. Construct your circuit without it. If you cannot control regeneration, put it in.

Hook up the circuit. Place the tube in its socket and close the switch. Tune the variable capacitor with the regeneration control (potentiometer) in different positions. You should hear hissing, squealing, or other signs of oscillation as you tune through stations. If these sounds are not heard, reverse the tickler leads.

Bring in a station with the variable capacitor. Adjust the ferrite slug in the loopstick so that best volume is obtained; leave the slug in this position. Advance the regeneration control until oscillation is heard. Readjust the variable capacitor for greatest volume, then back off the regeneration control until the oscillation just disappears. This is the position for best reception.

Regenerative-detector circuits are very sensitive and are capable of receiving signals over extremely long distances under good conditions.

## Chapter 8

### HOW TO LEARN THE CODE

Circuit No. 23:  
Code Practice Oscillator

parts needed:

doorbell, output or model train transformer  
 1.5- to 3-volt power supply  
 transistor, any type  
 500,000-ohm potentiometer  
 elegraph key

This is an audio oscillator. It is not a receiver, as it has no provisions for receiving, detecting, and amplifying a broadcast signal. Its sole purpose is to provide an audible tone in a pair of headphones or a loudspeaker.

Construct the circuit as shown. Almost any transistor can be used. The key acts as a switch, permitting current to flow in the circuit only when it is closed. If you do not have a key, you can make one very easily from a strip of sheet metal, as illustrated.

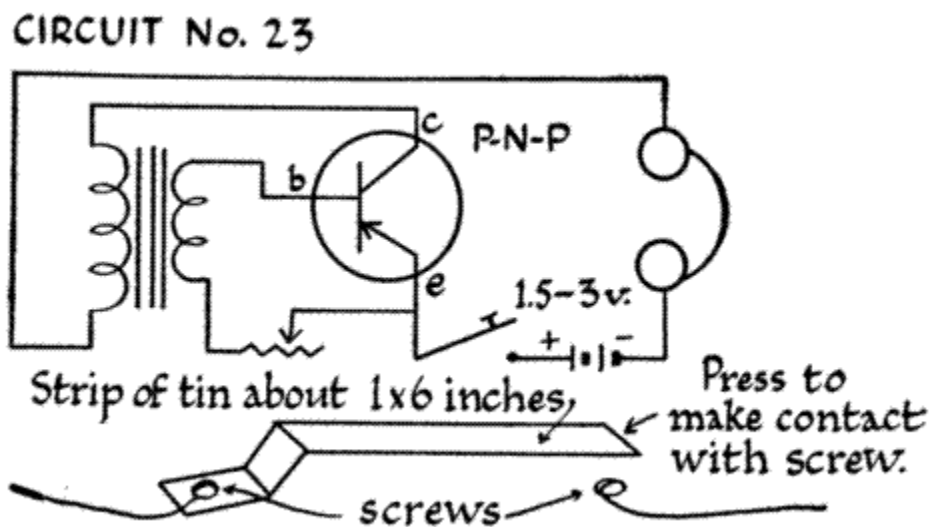

When the key is depressed, a tone should be heard in the headphones. The pitch of the tone can be varied by adjusting the potentiometer. If no tone is heard, turn the potentiometer all the way. If there is still no tone, reverse the secondary transformer leads; oscillation may not be taking place. Check all connections; there may be a break in the circuit.

Some output transformers will work only when they are connected in reverse. Hook up the primary leads where the secondary leads should be, and vice versa.

This oscillator will help you to become proficient in sending and receiving code. Radio amateurs use the Continental (International Morse) Code. You can practice in privacy at any time without disturbing anyone by using headphones.

## THE CONTINENTAL CODE

A .-	J .----	S ...	2 ..----	Period .....
B ....	K ---	T -	3 .....	Comma .....
C .....	L .....	U ...	4 .....	Question
D ...	M --	V ....	5 .....	mark .....
E .	N --	W ---	6 .....	Error .....
F .....	O ----	X .....	7 .....	End of
G ---	P .....	Y .....	8 .....	message .....
H ....	Q ----	Z .....	9 .....	
I ..	R ...	1 .----	0 .....	

It's easy to learn to send code; receiving code is more difficult. If you hook up a loudspeaker instead of phones (through a transformer, of course), a group of people can practice at the same time. Take turns sending and receiving.

The best way to learn the code is by thinking of each letter as a combination of sounds, rather than dots and dashes. Think of each dot as a dit, or short tone, and each dash as a dah, or longer tone. Here are the letters arranged in groups; learn one group before going on to the next:

E dit  
 I dit-dit  
 S dit-dit-dit  
 H dit-dit-dit-dit  
 5 dit-dit-dit-dit-dit

A dit-dah  
 U dit dit dah  
 V dit dit dit dah  
 3 dit dit dit dah dah  
 4 dit dit dit dit dah

R dit-dah-dit  
 W dit-dah-dah  
 L dit-dah-dit-dit  
 P dit-dah-dah-dit  
 J dit-dah-dah-dah  
 1 dit-dah-dah-dah-dah

T dah  
 N dah-dit  
 D dah-dit-dit  
 B dah-dit-dit-dit  
 6 dah-dit-dit-dit-dit

F dit-dit-dah-dit

2 dit-dit-dah-dah-dah  
 ? dit-dit-dah-dah-dit-dit

M dah-dah  
 G dah-dah-dit  
 Z dah-dah-dit-dit  
 Q dah-dah-dit-dah  
 , dah-dah-dit-dit-dah-dah  
 7 dah-dah-dit-dit-dit

K dah-dit-dah  
 C dah-dit-dah-dit  
 X dahdit-dit-dah

8 dah-dah-dah-dit-dit  
 9 dah-dah-dah-dah-dit  
 0 dah-dah-dah-dah-dah

End Of Message (EOM) dit-dah-dit-dah-dit  
 Period (.) dit-dah-dit-dah-dit-dah

## INDEX

aerial, see antenna  
 amplifier  
 amplifiers, how to build:  
   room-to-room communicator,  
   sound amplifier  
 antenna  
   indoor  
   arrestor, lightning  
 atoms:  
   structure of  
 audio frequencies  
 audio signal

base  
 battery:  
   solar, 85-87  
   bias, 100

capacitance, of electronic circuit  
 capacitors  
 carrier wave  
   modulated  
 cathode  
 cat s whisker detector

- charge, space
- choke, radio-frequency
- circuit, electrical
- circuit, radio
  - diagrams of
  - transistor
  - tuned
- Code. Continental
- code practice oscillator, how to build
- coding, color:
  - of resistors
  - of transformer leads
- coils
  - inductance of,
  - voice coil
- communicator, room-to-room, how to build
- components, radio
- conductor
  - semiconductor
- connection
- Continental Code
- crystal diode
- current, electric
  - alternating
  - direct
  - frequency of
- cycle, of electric current
  
- demodulation
- detection
- detector
- diagram, circuit
- diode
  
- electricity (see also current)
- electromagnet
- electromagnetic waves
- electron theory
- electrons
- elements
- emission:
  - secondary
  
- farad
- field, magnetic
- filament
- fixed capacitor
- flux
- free electrons
- frequencies, radio

galvanometer  
grid  
  grid leak  
  screen grid  
  suppressor grid  
ground  
ground clamp  
ground rod

headphones  
heterodyne  
hexagonal nuts  
high-impedance headphones  
hookup wire

impedance  
inductance  
induction  
insulators  
International Morse Code  
ionization  
ions  
irons, soldering

key, telegraph

lamp  
lead-in wire  
leads, wire  
  of transformers  
  of transistors  
lightning arrestor  
lodestone  
loopstick, ferrite  
loudspeaker  
lugs, soldering

machine screws  
magnet wire  
magnetic field  
magnetism  
megohm  
microfarad  
modulated carrier  
molecules  
Morse Code

nucleus, atomic

ohm  
oscillators, how to build:

- code practice oscillator
- wireless broadcast oscillator
- output transformer

- pencils, soldering
- penknife
- pentode
- permanent-magnet loud speaker
- phones
- photocell
- "pigtails" see leads, wire
- pliers
- PM loudspeaker
- potentiometer
  - mounting of
- push-back wire

- radio frequencies
- radio-frequency choke
- receiver

- receivers, how to build:

- crystal-detector receiver with hand-wound coil
- crystal-detector receiver with transistor amplifier
- crystal-detector receiver with tuned circuit
- "emergency" crystal-detector receiver
- one-tube regenerative receiver
- simple crystal-detector receiver
- single-transistor receiver with hand-wound coil
- single-transistor regenerative detector receiver
- two-transistor receiver
- two-transistor regenerative detector receiver
- vacuum-tube grid-leak detector receiver

- rectifier

- resistance

- resistor

- grid leak resistor

- RF, see radio frequencies

- screen grid

- screwdrivers

- screws, machine

- secondary emission

- selectivity

- selenium

- semiconductor

- series, battery cells in

- socket, vacuum-tube

- socket wrenches

- solar cell

- solder

- soldering



- soldering gun, electric
- soldering iron
- soldering lug
- soldering pencil
- space charge
- speaker
- suppressor grid
- switch

- terminal
- tetrode
- thermionic emission
- tickler
- tinning
- tools
- transformer
  - output transformer
- transistor
  - leads of, 52-53
- transistor receivers, how to build
  - crystal-detector receiver
  - simple transistor hookup
  - single-transistor receiver with hand-wound coil
  - single-transistor regenerative detector receiver
  - two-transistor receivers
  - two-transistor regenerative receiver
- transmitter
  - broadcast oscillator
  - Mode
- tube, vacuum
- tuning
  
- vacuum tube
- variable capacitor
- voice coil
- voltage drop

- waves, radio
- wire
  - hookup, 30
  - lead-in, 34
- wrenches, socket

- zero potential

## About the Author

Harry Zarchy has lived in and around New York all his life. For many years he has taught fine arts, ceramics, and crafts in New York City high schools and to adult groups as well. He is a man with an

amazing number of interests. Fishing, model trains, and music are some of them. He has played the violin, the banjo, guitar, cello, trumpet, and is a free-lance bass player. Working once as a watch maker, he developed a curiosity about old timepieces, which led to a book, Wheel of Time, He has also worked as a house painter, carpenter, cabinetmaker, counter man in a restaurant, and waiter. His house is full of electronic gadgets, such as an intercom system and an amateur radio station. He is a licensed "ham" operator and likes to relax by chatting with other amateurs. Mr. Zarchy makes his home on Long Island with his wife and two children.